

HygroMATIK®

member of CAREL group

CAREL

FlexLine

Control Climate

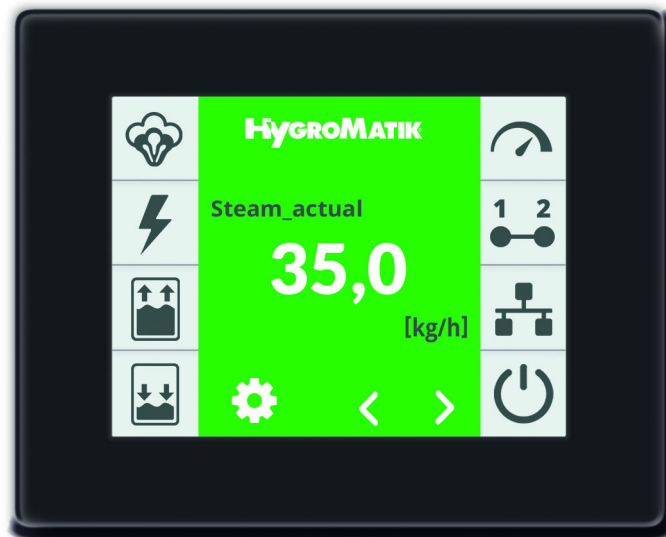

Manual



FL-T.EN
E-8881166

Certain computer programs contained in this product [or device] were developed by HygroMatik GmbH ("the Work(s)").

Copyright © HygroMatik GmbH [27.03.2025]

FlexLine Control

Validity: This documentation is valid for the control system of the Flexline device series

All Rights reserved.

HygroMatik GmbH grants the legal user of this product [or device] the right to use the Work(s) solely within the scope of the legitimate operation of the product [or device]. No other right is granted under this licence. In particular and without prejudice to the generality of the foregoing, the Work(s) may not be used, sold, licensed, transferred, copied or reproduced in whole or in part or in any manner or form other than as expressly granted here without the prior written consent of HygroMatik GmbH.

Information in this manual is subject to change or alteration without prior notice.

The device-specific wiring diagrams are included in the scope of delivery. Please keep them carefully for future use.

▲ WARNING

Risk of electrical shock!

Hazardous electrical high voltage!

All electrical work to be performed by certified expert staff (electricians or expert personnel with equivalent training) only.

1. Introduction	5
1.1 Typographic Distinctions	5
1.2 Documentation	5
1.3 Symbols in Use	5
1.4 Intended Use	6
2. Safety Instructions	7
2.1 Guidelines for Safe Operation	7
2.1.1 Scope	7
2.1.2 Unit control	7
2.1.3 Unit Operation	7
2.1.4 Mounting, dismantling, maintenance and repair of the unit	8
2.1.5 Electrical	8
3. Description of control	9
3.1 General description	9
3.2 Layout of control	9
3.3 Mainboard	10
3.3.1 Connections on the mainboard	11
3.4 Expansion board (double cylinder and TPRO units)	12
3.4.1 Connections on the expansion board	12
3.5 Relay circuit board	13
3.5.1 Connections on the relay board	13
3.6 Electrical connection	14
3.6.1 Connection of control voltage	14
3.6.2 Connection of interlock (safety) system	14
3.6.3 1 step operation	15
3.6.4 Operation with external controller or active humidity sensor	15
3.6.5 Connecting the digital input (DI)	16
3.6.6 Wiring for control signal and safety (interlock) system for multiple units	16
4. Screen	17
5. Operation of control	19
5.1 Operation basics	19
5.2 Screen 1 - Commissioning	21
5.2.1 Setting the language	21
5.2.2 Input of date and time	21
5.2.3 Control settings	22
5.2.4 Line-up of the commissioning parameters	23
5.3 Screen 2 - Main screen	24
5.3.1 Changing the set point humidity	25
5.4 Password entry	25
5.5 Screen 3 - Main menu (user level)	26
5.6 User level submenus	26
5.6.1 Settings submenu	27
5.6.2 Read values submenu	28

5.6.3 History submenu	31
5.7 Screen 3 - Main menu (operator level)	34
5.8 Operator level submenus	34
5.8.1 Settings submenu	35
5.8.2 Read values submenu	35
5.8.3 Control submenu	36
5.8.4 Service submenu	37
5.8.5 History submenu	39
5.8.6 Blow-down submenu	40
5.8.7 Fill parameters submenu	40
5.8.8 Functions submenu	41
5.8.9 Communication interface submenu	44
5.8.10 Weekly timer submenu	45
5.8.11 Recording submenu	45
5.8.12 Cylinder extension submenu	47
5.8.13 Relay extension 1 submenu	48
5.8.14 Relay extension 2 submenu	49
5.8.15 TPRO submenu	50
6. Faults and Warnings	54
6.1 Fault Management	54
6.1.1 Table of Fault Messages, possible Causes and Countermeasures	54
6.2 Service messages and warnings	60
6.3 Table of functional disruptions	61
7. Wiring diagrams	65
8. Glossary	66
9. Technical Data	71

1. Introduction

Dear Customer,

Thank you for choosing a HygroMatik steam humidifier.

HygroMatik steam humidifiers represent the latest in humidification technology.

In order to operate your HygroMatik steam humidifier safely, properly and efficiently, please read these operating instructions, which are supplemented by other operating instructions for the relevant basic unit.

Employ your steam humidifier only in sound condition and as directed. Consider potential hazards and safety issues and follow all the recommendations in these instructions.

If you have additional questions, please contact your expert dealer.

For all technical questions or spare parts orders, please be prepared to provide unit type and serial number (see name plate on the unit).

1.1 Typographic Distinctions

- Preceded by a bullet: general specifications
- » Preceded by an arrow: procedures for servicing or maintenance which should or must be performed in the indicated order
- ☑ Installation step which must be checked off.

italics Terms used with graphics or drawings

1.2 Documentation

Retention

Please retain these operating instructions in a secure, always accessible location. If the product is resold, turn the documentation over to the new operator. If the documentation is lost, please contact HygroMatik.

Versions in Other Languages

These operating instructions are available in several languages. If interested, please contact HygroMatik or your HygroMatik dealer.

1.3 Symbols in Use

Specific Symbols related to Safety Instructions

According to ANSI Z535.6 the following signal words are used within this document:

▲ DANGER

DANGER indicates a hazardous situation which, if not avoided, will result in death or serious injury.

▲ WARNING

WARNING indicates a hazardous situation which, if not avoided, could result in death or serious injury.

▲ CAUTION

CAUTION indicates a hazardous situation which, if not avoided, could result in minor or moderate injury.

NOTICE

NOTICE is used to address practices not related to physical injury.

General Symbols

Please note

This symbol is used whenever a situation requires special attention beyond the scope of safety instructions.

1.4 Intended Use

The control described is an integral part of a HygroMatik steam humidifier. Use for other applications is not permitted. All instructions on intended use, which are given in connection with the basic device, apply.

Proper usage also comprises the adherence to the conditions specified by HygroMatik for:

- installation
- dismantling
- reassembly
- commissioning
- operation
- maintenance
- disposal

Only qualified and authorised personnel may operate the unit. Persons transporting or working on the unit must have read and understood the corresponding parts of the Operation and Maintenance Instructions and especially the chapter 2. „Safety Notes“. Additionally, operating personnel must be informed of any possible dangers. You should place a copy of the Operation and Maintenance Instructions at the unit's operational location (or near the unit).

By construction, HygroMatik steam humidifiers are not qualified for exterior application.

▲ WARNING

Risk of scalding!

Steam with a temperature of up to 100 °C is produced.

Do not inhale steam directly!

2. Safety Instructions

These safety instructions are required by law. They promote workplace safety and accident prevention.

2.1 Guidelines for Safe Operation

2.1.1 Scope

Comply with the accident prevention regulation „DGUV Regulation 3“ to prevent injury to yourself and others. Beyond that, national regulations apply without restrictions. This way you can protect yourself and others from harm.

2.1.2 Unit control

Do not perform any work which compromises the safety of the unit. Obey all safety instructions and warnings present on the unit.

In case of a malfunction or electrical power disruption, switch off the unit immediately and prevent a restart. Repair malfunctions promptly.

⚠ WARNING

Restricted use.

IEC 60335-1 stipulates as follows:

This device may be used by children of eight years of age and above as well as by persons with reduced physical, sensory or mental capabilities or lack of experience and knowledge so long as they are supervised or have been instructed regarding the safe use of the device and understand the hazards that may result from it. Cleaning and user maintenance of the unit must not be undertaken by children without supervision.

2.1.3 Unit Operation

⚠ WARNING

Risk of scalding!

Uncontrolled hot steam escape in case of leaking or defective components possible. Switch off unit immediately.

⚠ WARNING

For Ministeam devices applies:

Risk of scalding!

No persons may be under the cloud of steam blowing out (at a distance of approx. 1 m/40 inch in the direction of blowing out and 0.5 m/ 20 inch on both sides of the device).

NOTICE

Risk of material damage!

- The unit may be damaged if switched on repeatedly following a malfunction without prior repair. Rectify defects immediately!
- The unit must not be operated on a DC power supply.
- The unit may only be used connected to a steam pipe that safely transports the steam (not valid for MiniSteam units).
- Regularly check that all safety and monitoring devices are functioning normally. Do not remove or disable safety devices.
- Steam operation is only allowed when the unit cover is closed.

NOTICE

Water leaks caused by defective connections or malfunctions are possible.

Water is constantly and automatically filled and drained in the humidifier. Connections and water-carrying components must be checked regularly for correct operation.

2.1.4 Mounting, dismantling, maintenance and repair of the unit

NOTICE

The HygroMatik steam humidifier is IP20 protected. Make sure that the unit is not object to dripping water in the mounting location.

Installing a humidifier in a room without water discharge requires safety devices to protect against water leakages.

-
- Use genuine spare parts only
 - After any repair work, have qualified personnel check the safe operation of the unit
 - Attaching or installing of **additional components** is permitted only with the **written consent** of the manufacturer

NOTICE

Do not install HygroMatik steam generators above electrical equipment such as fuse boxes, electrical appliances, etc. In the case of a leakage, leaking water can damage the underlying electrical equipment

2.1.5 Electrical

⚠ WARNING

Risk of electrical shock!

Hazardous electrical voltage!

Any work on the electrical system to be performed by certified expert staff (electricians or expert personnel with comparable training) only.

Steam operation may only be started when the unit cover is closed.

During maintenance or installation work, the device must be disconnected from the power supply and secured against being switched on again. The absence of voltage must be ensured by a measurement.

Leaks can cause leakage currents. Observe safety regulations on working with voltage parts (applies to electrode steam humidifies).

After electrical installation or repair work, test all safety mechanisms (such as grounding resistance).

NOTICE

Use only original fuses with the appropriate amperage rating.

Regularly check the unit's electrical equipment. Promptly repair any damage such as loose connections or burned wiring.

Responsibility for intrinsically safe installation of the HygroMatik steam humidifiers is incumbent on the installing specialist company.

3. Description of control

3.1 General description

The control is integrated into the steam humidifier and is operated via a 3.5" graphic display on the front of the unit.

The only other operating element, which is also located on the front of the unit, is a control switch whose positions are assigned as follows:

Pos. "0": The unit is switched off

Pos. "I": The unit is switched on and the control is active

Pos. "II": The cylinder water is pumped off manually without the participation of the control. The control is not active, the display remains dark.

Control switch



By changing the parameters, the user/operator can adapt the control to the system specifications and the special characteristics relating to the use of the unit.

Details of the operation of the unit are provided in the Glossary (see Section 6).

3.2 Layout of control

The control consists of the 3.5" screen and the mainboard. The mainboard can be expanded for additional functions with one or 2 relay boards (with 3 relays each) and additional optional relays in DIN rail format.

The relay boards are connected to the mainboard via a plug system.

The DIN rail relays are connected via cables with plug. 2 additional relay modules can be used, with 2 relays each.

For use with double cylinder units, an expansion board is added to the mainboard.

The fuse protection of the control voltage for all boards with 2 x 2.5 A fast (F1, F2) takes place on the mainboard.

The external circuitry for the control voltage and the interlock (safety) system are connected directly to the mainboard on plug ST1. If additional boards are connected, the connection moves from the mainboard to the outermost board (see sketch).

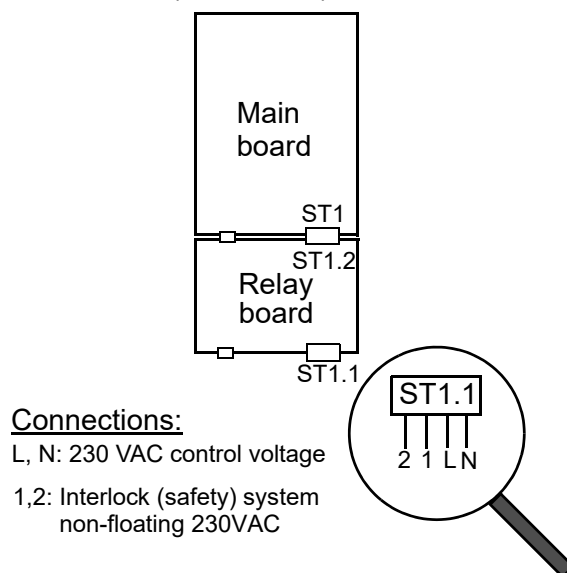

Please note

For device versions with separate control voltage, this is connected to clamps L and N. For versions with internal control voltage and control voltage transformer, the wiring is pre-installed here.

3.3 Mainboard

The mainboard is "the heart" of the control. All logic functions and control operations for the steam humidifier are provided here. The relays for the control of the main contactor, solenoid valve and blow-down pump are included directly on the mainboard.

Ex-factory relay assignment:

In case of a unit without any additional options built in, assignment of the base relay (ST03) is „Collective fault“ (0). All other relay contacts carry the assignment „Not in use“ (284).

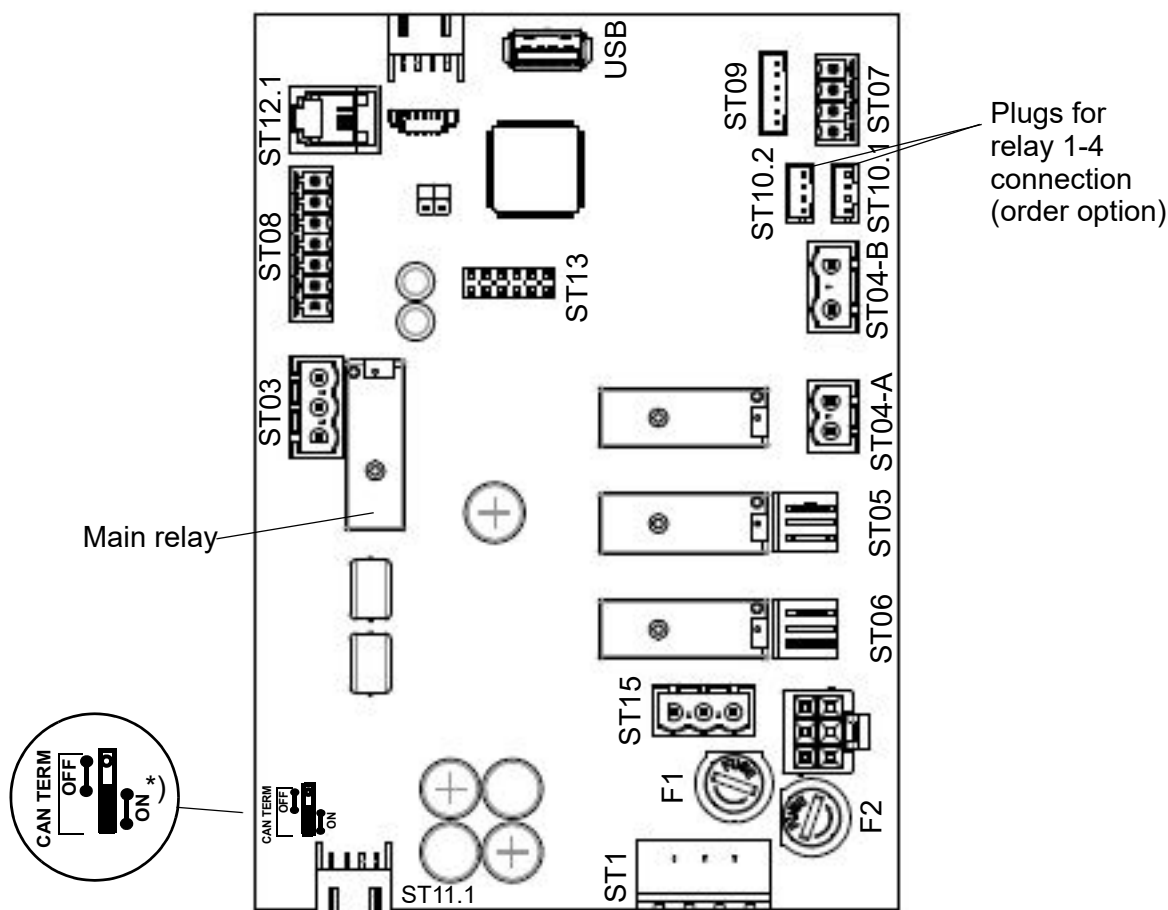

*) This jumper must always be set to „ON“

3.3.1 Connections on the mainboard

The use of the connections is illustrated by the wiring diagrams (see chapter 7)

Customer-side computer interfaces

Inputs

ST08:

Possible external controller signals	
0(2) - 5 V DC	min. 0,1 mA**
0(2) - 10 V DC	min. 0,2 mA**
0(4) - 20 V DC	min. 0,3 mA**
0(4) - 20 mA DC	min. 3 V**
0 - 140 Ohm*	

* only for operating mode external controller

** minimum power of the control signal

- Configurable digital input 12 VDC

Outputs

ST03:

- Potential free break/make contacts NC and NO, programmable, relay assigned to "Collective fault" in factory setting

ST10.1/ST10.2:

- Connection options for an optional relay each in DIN rail version with wiring harness (order option)

ST07:

- Control output 0...10 VDC (max. 8 mA)

ST08:

- +20 VDC supply voltage (max. 20 mA) for humidity sensors

ST15:

- Tap for L1 and N (unsecured) for customer use

USB:

Connection for USB stick for use as a data logger and for parameter updates

System-side interfaces

ST1:

- 4-pin screw / plug connection for the connection of L1 and N and the interlock (safety) system

ST11.1:

- +12 V, GND, CAN bus

Inputs

ST09:

- Input for current transformer (ELDB) / level control (HKDB) with automatic detection (for explanation of terms see Glossary, Index 7)

ST04-B:

- Galvanically isolated input (optical coupler) for sensor electrode

Outputs

ST04-A:

- Main contactor

ST05:

- Blow-down pump

ST06:

- Inlet solenoid valve

Bi-directional

ST12.1:

- Serial interface for screen connection

ST 13:

- Base for adapter board with RS485 interface

3.4 Expansion board (double cylinder and TPRO units)

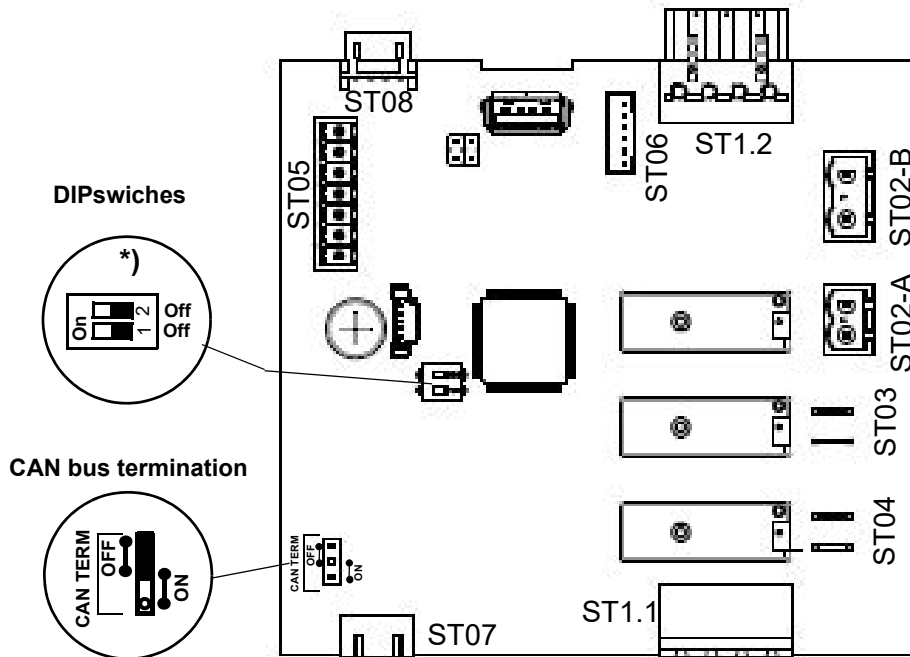

*)The DIP switches serve for CAN bus address setting. They are factory preset according to the unit configuration:
 Double cylinder expansion board: DIP-Schalter 1-OFF and 2-OFF
 FLE-TRPO expansion board: DIP-Schalter 1-ON and 2-ON
 FLH-TPRO expansion board: DIP-Schalter 1-ON and 2-OFF

**) The jumper for the CAN bus termination is in the „ON“ position only on the lowest extension or relay board of the assembly, i.e. the termination is then effective. On the boards that are attached in higher mounting positions, the correct jumper setting is „OFF“. On

3.4.1 Connections on the expansion board

Customer-side computer interfaces

Inputs/outputs

ST05: not used

System-side interfaces

ST1.1:

- 4-pin screw / plug connection for the connection of L1 and N and the interlock (safety) system

ST1.2:

- Loop-through of ST1.1

ST07:

- +12 V, GND, CAN-Bus

ST08:

- Loop-through of ST07

Inputs

ST02-B

- Electrically isolated input (optical coupler) for sensor electrode (ELDB)
- Thermoswitch connection (HKDB)

ST06:

- Input for current transformer (ELDB) / level control (HKDB) with automatic detection

Outputs

ST02-A:

- Main contactor

ST03:

- Blow-down pump

ST04:

- Inlet solenoid valve

3.5 Relay circuit board

The relay board has three additional relays with potential free break/make contacts (contact load 250 VAC/8 A) for switching or controlling of additional functional units or options.

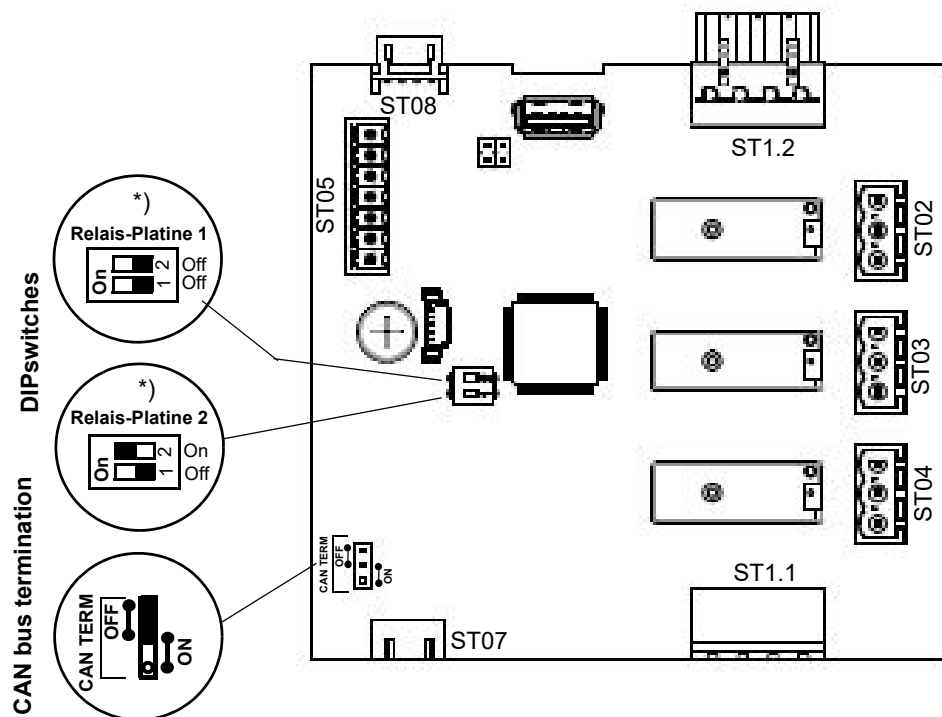

*) The DIP switches serve for CAN bus address setting. They are factory preset according to the unit configuration.

**) The jumper for the CAN bus termination is in the „ON“ position only on the lowest extension or relay board of the assembly, i.e. the termination is then effective. On the boards that are attached in higher mounting positions, the correct jumper setting is „OFF“. On the main board the correct setting of the Can-Bus termination is always "ON"..

3.5.1 Connections on the relay board

Customer-side interfaces

Inputs

ST05:

- Configurable digital input 12 VDC

Outputs

ST02:

- Potential free break/make contacts NC and NO, programmable

ST03:

- Potential free break/make contacts NC and NO, programmable

ST04:

- Potential free break/make contacts NC and NO, programmable

A maximum of 2 relay boards can be installed. When 2 boards are in use, different CAN bus addresses must be set (see fig. below).

3.5.1.1 System-side interfaces

ST1.1:

- 4-pin screw / plug connection for the connection of L1 and N and the interlock (safety) system

ST1.2:

- Loop-through of ST1.1

ST08:

- +12 V, GND, CAN bus

ST07:

- Loop-through of ST08

3.6 Electrical connection

⚠ WARNING

Danger of electric shock!

Dangerous electric voltage!

All work relating to the electrical installation may only be carried out by designated specialist personnel (electrician or qualified person with equivalent training).

Please note

The customer is responsible for monitoring the qualifications of the specialist personnel.

NOTICE

Potential component damage due to electrostatic discharge!

To protect the sensitive electronic components, measures to prevent damage due to electrostatic discharge must be taken before the start of the installation work.

NOTICE

Risk of damage due to excessive current consumption via the circuit board

The control boards of the FlexLine and StandardLine device series provide a maximum of 30 mA. If consumers with higher current requirements are to be connected, it is imperative that you consult your specialist dealer beforehand.

3.6.1 Connection of control voltage

The control voltage of 230 VAC is to be applied to the board which is closest to the cable gland on the underside of the housing. The plug designation differs depending on the level of expansion:

Type of board	Plug designation
Mainboard	ST1
Expansion board	ST1.1
Relay circuit board	ST1.1

The pin assignment is identical for all plugs. L and N are labelled on the boards. The pins are accessible via a terminal strip adaptor pushed on the corresponding plug.

For device versions with internal control voltage, no voltage must be applied to L and N. The wiring is pre-installed here.

3.6.2 Connection of interlock (safety) system

The so-called interlock (safety) system is located between terminals 1 and 2. Safety equipment can be wired (also in series) into the interlock (safety) system. If the interlock (safety) system is open, the humidifier does not start or the operation is interrupted.

In air conditioning, it is standard to incorporate a max. hygostat in the interlock (safety) system. The max. hygostat is used as a safety feature in case of a malfunction of the humidity sensor.

⚠ WARNING

Danger of electric shock!

Dangerous electric voltage!

After the initial operation of the unit, a 230VAC voltage is present at terminal 1 when standard wiring is used.

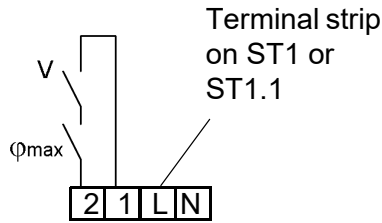

Terminals 1/2 on the mainboard (terminal strip on ST1) or an extension/relay board (terminal strip on ST1.1) provided for connection of the interlock (safety) system

Please note

The interlock (safety) system is not closed when delivered ex-factory!

Please note

The contacts, which are connected to terminals 1 and 2 must be potential free and suitable for switching of 230 VAC.

3.6.4 Operation with external controller or active humidity sensor

When the steam humidifier is controlled via an external controller (e.g. a PLC) or an active humidity sensor, physical control signals can be processed in the range 0...10 V, 0...20 mA or 0...140 Ω. A separate terminal is provided on the board for each of these signal types (also see chapter 7, „Wiring diagrams“). Terminal 4, "GND" is the reference potential in each case.

Wiring examples

External controller

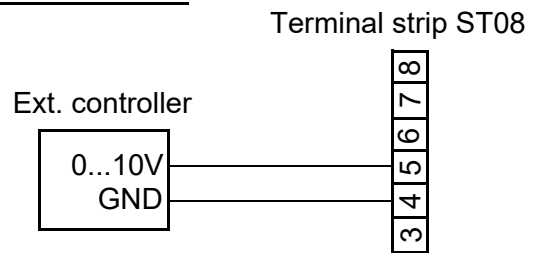

Terminals 4/5 on the mainboard (terminal strip ST08) provided for connection of an ext. control signal 0...10V

3.6.3 1 step operation

The operation of the steam humidifier is controlled via terminals 3 and 5 by the contact which is to be provided on-site. The contact only has to be suitable for low voltage.

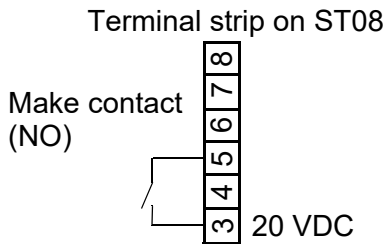

Terminals 3/5 on the mainboard (terminal strip on ST08) provided for 1-step operation

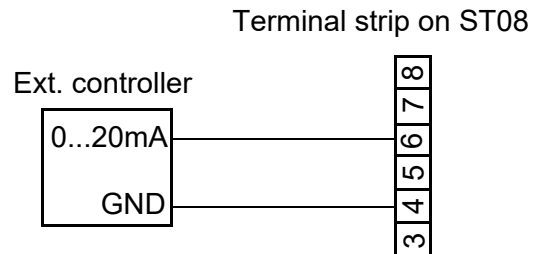

Terminals 4/6 on the mainboard (terminal strip on ST08) provided for connection of an ext. control signal 0...20mA

Humidity sensor

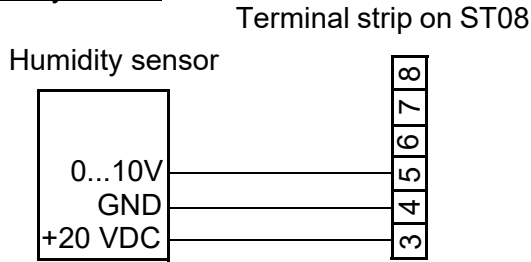

Terminals 3/4/5 on the mainboard (terminal strip on ST08) provided for connection of a humidity sensor 0...10V

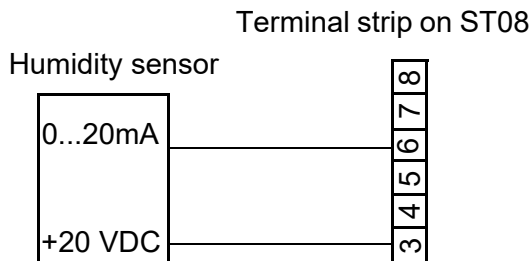

Terminals 3/6 on the mainboard (terminal strip on ST08) provided for connection of a humidity sensor 0...20mA

Please note

Humidity sensors require an external supply voltage. 20 VDC are available for this purpose at terminal 3.

Humidity sensor with higher current requirement

The circuit board provides a maximum of 30mA. If this is not sufficient for the connected humidity sensor, use the option of a transformer to supply the sensor with power.

3.6.5 Connecting the digital input (DI)

The digital input on the mainboard can be used for switching functions.

The digital input must be wired on-site in accordance with its use, e.g. with a push-button or a switch (also see chapter 5.8.8 „Function parameters“).

Digital input (DI) wiring examples

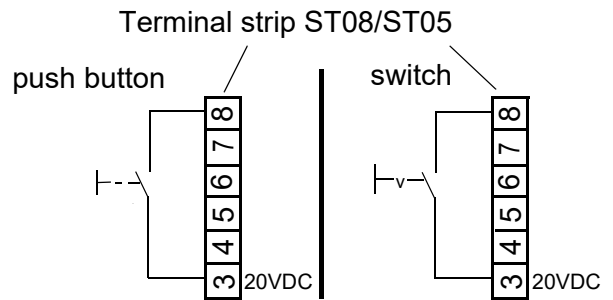

Terminals 3/8 provided for connecting the digital input

- mainboard (terminal strip ST08)
- extension board/relay board (terminal strip ST05)

3.6.6 Wiring for control signal and safety (interlock) system for multiple units

In the case of multiple units, separate humidifiers work together. The control signal and the safety (interlock) system are connected to the master unit as described above. In addition, connecting cables are established between the guiding unit and the succeeding unit(s) (provided on-site). These provide the succeeding unit with a control signal from the guiding unit and the transmitted (potential free) safety (interlock) system.

The wiring for the control signal and the safety (interlock) system must be implemented as follows for multiple units:

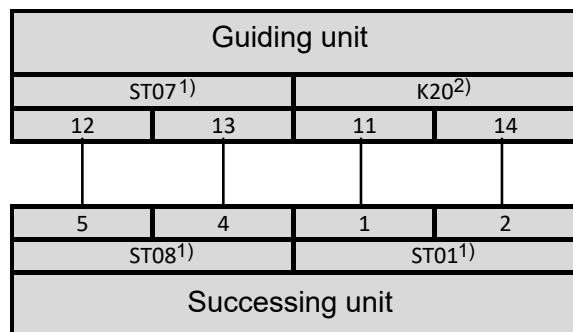





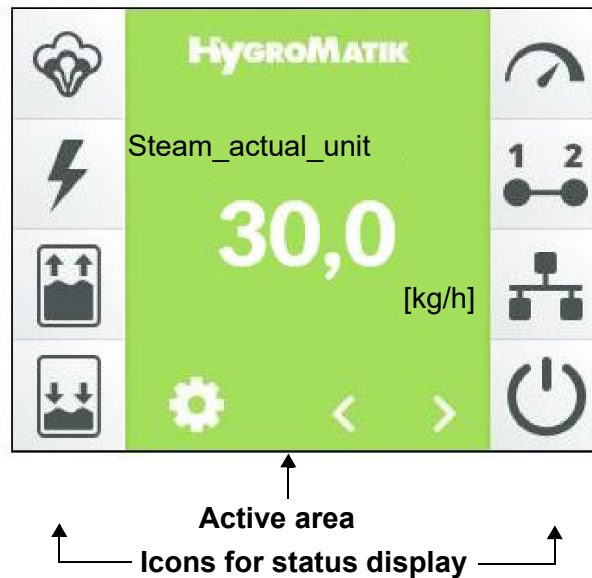

1) „ST0x“ designates connector plugs on the mainboard

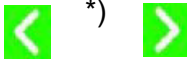







2) „K20“ is the relay used for the connection of the succeeding unit with the installed option (CN-07-10012) or the enclosed option (CN-07-10002)

4. Screen



Active screen area	Use
	Main display for operating values, navigation using the scroll keys ^{*)} .
 ^{*)}	Scroll keys can be used to display the following operating values: <ul style="list-style-type: none"> • Humidity_actual_value [%] • Humidity_set_value [%] ^{1),2)}; touching it opens a screen keyboard ^{**)} that allows for changing the set value • Steam_actual_unit [kg/h] • Steam_output_max. [%] • Demand [%] • Control_signal_internal [%] • Output_signal • Current_actual_cyl. 1 [A] (Electrode steam humidifiers only) • Current_actual_cyl. 2 [A] (Electrode steam humidifier double cyl. units only) • Waterlevel_cyl. 1 [mm] (Heater steam humidifiers only) • Waterlevel_cyl. 2 [mm] (Heater steam humidifier double cylinder units only) ¹⁾ only when „PI controller“ is set ²⁾ not in „Weekly timer“ mode; exemption: when „ECO“ is selected as the steam production mode, the humidity set-value is output in „Weekly timer“ mode as well.
^{**)} 	Screen keyboard for changing the humidity set value; is displayed when the humidity set value display is touched; allows direct changing of the set value. Saving of the input by touching the confirmation tick in the upper right corner, exit without saving by touching the „X“ in the upper left corner.

Active screen area	Use
	Button to call up set-up mode (via password). Password „000“ -> operating functions of user level (see Section 5.5) Password „010“ -> operating functions of operator level (see Section 5.7)
  Fault (001)  Service (01)	In the event of a fault or a service message, the relevant display field is shown instead of the HygroMatik logo. Touching it opens the unit info screen (see Section 5.9).
	Unit info screen (see Section 5.9) for the display of error and service messages in plain text. Is displayed by touching the error or service message.

Icon	Status	Meaning
	dark	Steam generation active
	bright	No steam generation
	flashes	Cylinder full; <u>when fault display is additionally shown:</u> Fault steam generation (see chapter Faults and Warnings)
	dark	Main contactor switched
	bright	Main contactor not switched
	flashes	Fault main contactor
	dark	Filling active
	bright	No filling
	flashes	Fault filling
	dark	Blow-down active
	bright	No blow-down
	flashes	Fault blow-down
	<u>Manual blow-down</u> A manual blow-down can be triggered by touching the icon. Touching the icon again stops the manual blow-down. Max. blow-down time corresponds to the parameter setting for full blow-down	
	dark	Demand has been made
	bright	No demand has been made
	flashes	Fault demand
	dark	Interlock (safety) system closed
	bright	Interlock (safety) system open
	dark	Virtual interlock (safety) system closed (via communication interface)
	bright	Virtual interlock (safety) system open
	dark	Operating mode display
	bright	No humidity control enabling due to e.g. open safety interlock (details can be found in Read_values/Status_unit).
	flashes	Unit is in the initialisation phase

5. Operation of control

5.1 Operation basics

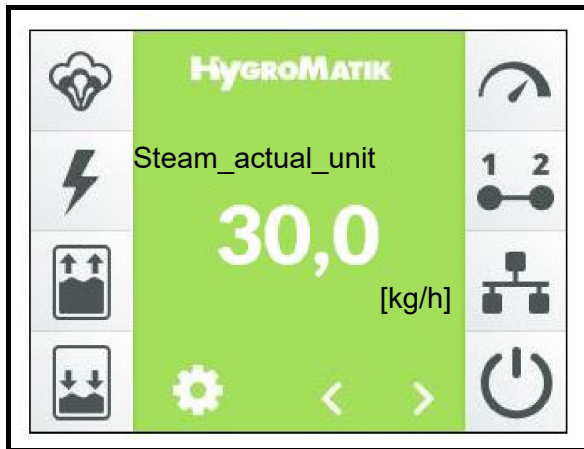

Operation takes place via the built-in touch-sensitive 3.5 inch screen. It is used for all operating steps required for the settings and operation of the unit. In addition to operating the unit directly, it is possible to control it remotely via the building technology control system or a PLC, using the communication interface. Supplementary documentation is available from HygroMatik for this type of application.



Screen views

The operating structure uses several screens, which are schematically displayed in the table below.

User guidance

In the user guidance, a distinction is made between the "user level" and "operator level". While the user level only makes it possible to carry out basic device operations, the operator level also permits operating parameters to be changed. The 2nd table below clarifies this again. The possible operating functions of the two levels are presented in Sections 5.5 and 5.7.

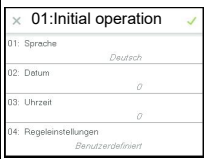
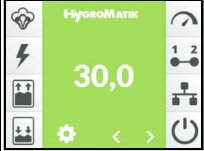
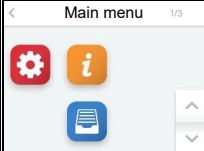
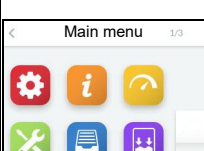
Overview of the screens

	Content of screen page	Presentation	Sec.
Screen 1 Initial operation	Used for the basic unit settings (e.g. user language) after the unit is switched on for the first time. This page is then closed. To do so, use the confirmation tick to exit it.		5.3
Screen 2 Main screen	Displays the current operating values and unit status information (status icons).		5.4
Screen 3 Main menu (user level)	Allows access to submenus for limited unit settings, read values and history.		5.5
Screen 3 Main menu (operator level)	Allows access to submenus for comprehensive unit settings, read values, parameter settings, service settings and history.		5.7
Screen 4 Unit information	Is only displayed after a fault or a service message has occurred; provides information on device data, statistics, faults that have occurred and service requirements.		5.9

Operating ranges at the user/operator level

Level	Permits
User level	<ul style="list-style-type: none"> • Display of the read values of the main screen • Setting the humidity set value in the main screen • Display of the unit information after a fault or status message • After entering the password - call-up and cancellation: Display of the complete list of read values and adjustment options for some service parameters
Operator level	<ul style="list-style-type: none"> • All functions of the user level • Advanced settings options for operation and service parameters

5.2 Screen 1 - Commissioning

After connection to the mains supply and initial actuation of the control switch, the commissioning screen for the basic device settings appears on the display once the self-test of the control has been completed:

X	01: Commissioning	✓
01: Language	<i>English</i>	
02: Date	<i>31/10/2017</i>	
03: Time	<i>11:59</i>	
04: Control	<i>User-defined</i>	

5.2.1 Setting the language

- » Touch the line with parameter "01: Language". The following screen is displayed:

<	Language	✓
<i>German</i>		
English		✓
<i>Français</i>		
<i>Castellano</i>		∨

The currently selected language is marked with a tick in the relevant line. With the scroll-down button, the 2nd page of the screen is displayed if required.

- » Change the language by touching it, if required

- » Confirm the input and return to the "Initial operation" screen with the green tick in the top right (cancel by touching "X")

5.2.2 Input of date and time

The parameter "02: Date" and "03: Time" require digits to be entered. To do so, a screen with a keyboard and an input field in the date or time format will be displayed after touching the relevant line.

As an example, the date input is described below:

- » Touch line "02: Date". The following screen is displayed:

X	Date	✓
28.10.21	1 2 3	
	4 5 6	
	7 8 9	
	. 0	⌫

- » Enter the date in the format DD.MM.YY (D = day, M = month, Y= year) as digits only (the dots are added automatically)
- » Confirm the input and return to the "Initial operation" screen with the green tick in the top right (cancel by touching "X")

5.2.3 Control settings

The type of unit control is specified in the next step. The screen offers the most commonly used combinations of the operating mode of the control (1 step, controlled with an external regulator, with the internal PI controller, via the communication interface, slave operation), the type of control signal (voltage, current or resistance signal) and the control signal range (e.g. 0... 10 V). If these values have already been factory-preset according to customer requirements, the selection tick appears in the "User-defined" line.

The parameters are displayed in blocks on a screen page, which include a maximum of 4 entries. Scroll keys are used to switch between the individual screen blocks.

The initial operation is now complete. If the initial operation screen was exited with the confirmation tick, the main screen is automatically shown in the display. The initial operation screen is no longer displayed in future. Future changes with respect to the parameters set during initial operation must be made on operator level in submenus „Settings“ and „Control“.

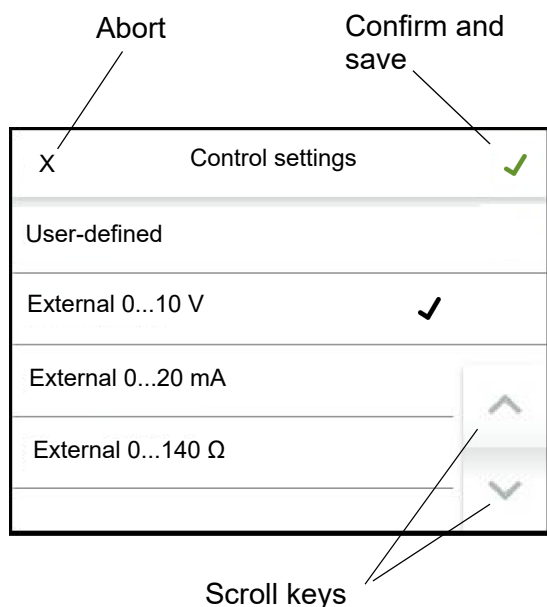

- » Confirm the input and return to the "Initial operation" screen with the green tick in the top right (cancel by touching "X")

- » Pressing the green tick in the top right saves the entries and exits the initial operation screen (cancel by pressing the "X")

5.2.4 Line-up of the commissioning parameters

Table of commissioning parameters

01: Commissioning

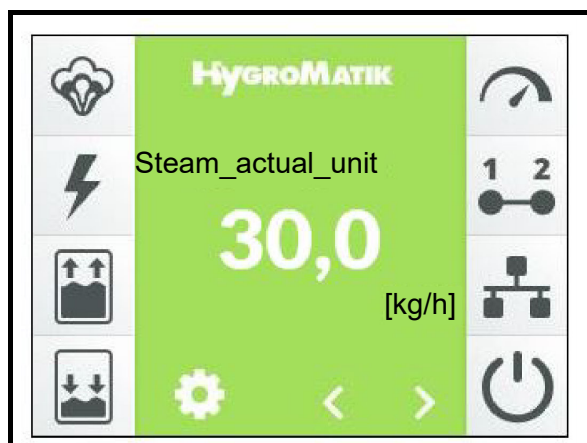

No. Parameter	No.	Adjustment/value range			Meaning/Comment [] explains the term in the glossary →[] refers to a related explanation of the term
		Factory setting (FS)	Min	Max FS	
1 Language		Selection			Selection of language
	0	Deutsch			Deutsch
	1	English			English
	2	Francais			French
	3	Castellano			Spanish
	5	Italiano			Italian
	6	Русский			Russian
	7	Svensk			Schwedish
	8	Dansk			Dansk
	9	Finnish			Finnish
	10	Polish			Polish
2 Date		DD.MM.YY			Set date
3 Time_of_day		HH:MM			Set time
4 Control_settings		Selection			Combinations of control type and input signal type/range
	0	User_specified			The selection was carried out separately during initial operation according to control type, signal type and area. This is a read value only
	1	Extern_0...10 V			External controller [73] with voltage signal 0... 10 V
	2	Extern_0...20 mA			External control [73] with current signal 0...20 mA
	3	Extern_0...140 Ω			External controller [73] with ohmic signal 0...140 Ω
	4	PI-controller_0...10 V			Internal PI controller [96], controls with voltage signal 0...10 V
	5	PI-controller_4...20 mA			Internal PI controller [96], controls with current signal 4... 20 mA
	6	PI-controller_0...140 Ω			Internal PI controller [96], controls with ohmic signal 0...140 Ω
	7	1-step			1 step operation [44]
	8	Modbus			Control via software control commands [12] through communication interface [13]
	9	Slave			
	11	Pi-controller_V_max_mA			Selection of current input on the mainboard for the 2nd PI controller when using the floating max. limiter [35]
	21	External_V_Max_mA			Selection of voltage input for external controller [73] 0...10V and current input for floating max. limitation [35] 4...20mA on the main board.
5 Recording		Selection			Recording [93] of parameter sets
	0	Deactivated			No recording
	1	Activated			Start recording

5.3 Screen 2 - Main screen



The main screen is shown in the display after the unit is switched on, unless the unit is being switched on for initial operation (see Section "Initial operation"). In the main screen, current operating values are represented as numerical information, as well as status information in the form of icons. The display elements were described in Section 4 "The screen". A flashing icon always indicates a fault.

The left row of icons refers to the operational conditions of the unit. The right row of icons indicates the status of releases. For steam production to take place, all icons on the right side of the screen must be active.

The scroll keys  and  allow the user to move through the list of display values on the main screen (see Section 4, "The screen"). With the exception of the target humidity, these are read values only. The displayed values are shown and explained in the table in the following section.

If an error has occurred or a service message is issued, a display field with the relevant message is displayed instead of the HygroMatik logo. The user can access the unit info screen by touching this field.

The brightness of the main screen is reduced after a certain time (screen brightness is dimmed). The two scroll keys and the settings icon are also hidden at this point. The original state is restored by touching the screen.

The values for the normal display brightness and the dimmed state can be adjusted by the user, as well as the duration after which the main screen is changed to the dimmed state.



The main menu of the user level and the operator level (screen 3) is accessed by touching the  icon. List of read values and target humidity of the main screen

Table of the read values available in the main screen and the humidity set value (only when operating with the internal PI controller)

No.	Parameter	No.	Adjustment/value range			Meaning/Comment [] explains the term in the glossary →[] refers to a related explanation of the term
			Factory setting (FS)	Min	Max	
	Humidity_actual_value				Read value	Actual value [1] of rel. humidity [2] in %
	Humidity_set_value		0,0	99,0	50,0	Set value [3] of RH [2] in %
	Steam_actual_unit				Read value	Current steam output of the unit [4] in kg/h
	Output_max.				Read value	Set value of maximum output power [43]
	Demand				Read value	The demand [5] is the control signal from which the internal actuator signal [42] is created
	Control_sig_internal				Read value	Internal actuator signal [42] as a percentage of the actuator signal for the nominal output
	Control signal_Cyl. 1				Read value	Internal actuator signal [42] as a percentage of the actuator signal for the nominal output
	Control signal_Cyl. 2				Read value	Internal actuator signal [42] as a percentage of the actuator signal for the nominal output
	Output_signal				Read value	Output signal [69] on terminals 12, 13 proportional to input signal
	Current_actual_cyl. 1				Read value	The current power consumption of cylinder 1 (only for ELDB [77])
	Current_actual_2_cyl. 1				Read value	Rated current of the second transformer of cylinder 1 of the humidifier in A
	Current_actual_cyl. 2				Read value	The current power consumption of cylinder 2 (only for ELDB [77] double cylinder units)
	Water_level_cyl. 1				Read value	Water level in cylinder 1 in mm (only for HKDB [78])
	Water_level_cyl. 2				Read value	Water level in cylinder 2 in mm (only for HKDB [78] double cylinder units)
	Humidity_actual_max				Read value	Actual value [1] of rel. humidity [2] in % when floating max. limiter [35] is activated
	Humidity_set_max		5,0	99,0	80,0	Specification of max. humidity for the switch-off point when using the floating max. limiter [35]

5.3.1 Changing the set point humidity

- » Select the "Humidity_set value [%]" screen using  or .
- » Tap on the Humidity_set value display.
- » Enter the value of the intended humidity set value using the on-screen keyboard which has opened.
- » Confirm the input and save using the check mark in the top right, cancel using the "X" in the top left.

5.4 Password entry

The password determines if the main menu of the user level or the operator level is displayed. The password codes in use are:

Code 000: The main menu of the user level becomes accessible. However, it is sufficient to leave the password prompt with the green tick, without explicitly entering the code.

Code 010: The main menu of the operator level becomes accessible.

The password entry is called up in the main screen by touching the  button. A virtual keyboard is shown on the screen for entering the password:

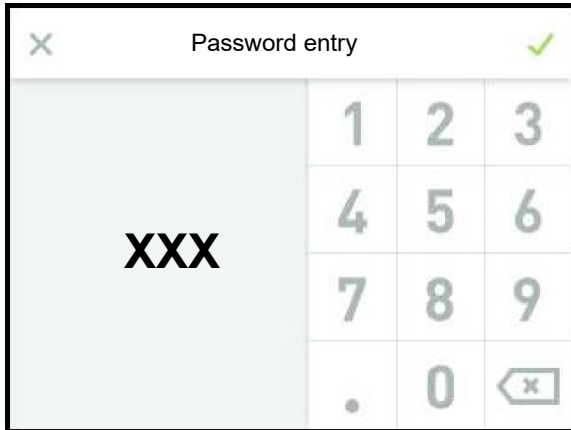



To open the user level, it is sufficient to select the X symbol (top left). The operator level is accessed through the sequential input of the code digits "0", "1" and "0" and confirming them with the green tick (top right).

5.5 Screen 3 - Main menu (user level)

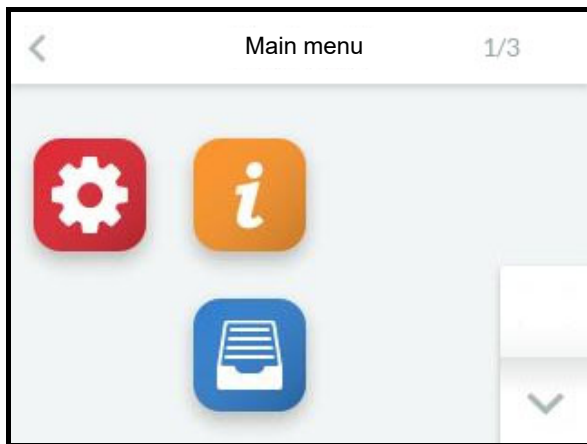
After selecting the user level, the icons of the submenus which are available to the user are displayed:



5.6 User level submenus

Icon	Selection of submenu
	Settings
	Read values
	History

By tapping on the respective icon, the user accesses the screen page where the parameters of the respective group are displayed for selection, viewing or for making changes.

Layout of screen page

The input fields in which changes can be made are shown in *italics*. Depending on the parameter, the input has to be made by:

- selection from predefined offers (multiple choice, see example 1)
- entry of numeric values using an on-screen keyboard (see example 2).

Example 1: Selection of user language:

Call up the language selection on the screen by touching "Language:

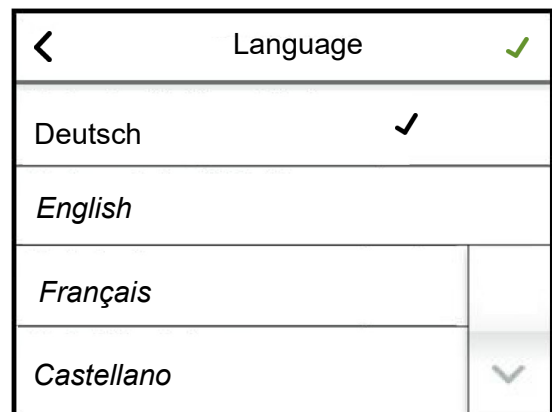

By tapping on the required language, the black tick moves to the corresponding row. By touching the green tick (top right), the selection is saved and the display returns to the parent screen.

If the settings are to remain unchanged, it is possible to return straight away using the < key.

Example 2: Setting the screen brightness

Touch "Screen_brightness normal" on the screen to call up the input mask:

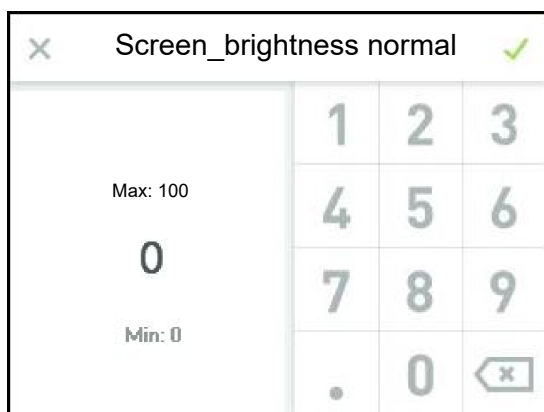

The screen brightness which is set is displayed and can be changed by using the keyboard. Save and return by touching the green tick, leave the input mask without changes by touching the "X".

The screens are hidden after a certain period of time. The main screen is then displayed. The time until the return to the main screen can be set by the user.

If a submenu is to be called up again after a screen has been closed automatically by a time-out, this can only be done through the settings icon in the main screen. This also means that the password has to be re-entered. As long as the user continues their work in the area of the main screen, the existing access remains, i.e. no renewed password entry is required.

5.6.1 Settings submenu



Table of settings parameters (user level)

03: Settings

No.	Parameter	No.	Adjustment/value range			Meaning/Comment
			Min	Max	FS	
1	Language		Selection			Selection of language
			see: 01-1 Language			
2	Date		DD.MM.YY			Set date
3	Time_of_day		HH:MM			Set time
4	Display_lighting_normal		50	100	100	Screen backlight in undimmed state
5	Delay_present_page		0	3600	300	Display duration for a certain screen page before return to the main screen in min
6	Display_lighting_dimmed		30	100	50	Screen brightness for dimmed state
7	Display_dim_after		0	3600	120	Switching of screen brightness of main screen to dimmed value after ... seconds. If an error has occurred or a status message is displayed, the main screen is not dimmed
8	Units		Selection			Selection of system of units
		0	SI			Units are displayed in the format of the SI system of units [8]
		1	Imperial			Units are displayed in the format of the imperial system of units [9]
9	Address		0	255	1	Address of the communication interface of display [13]
10	Baud_rate		Selection			Setting the baud rate
		3	9600			9600
		4	19200			19200
		6	38400			38400
11	Parity		Selection			Parity setting
		0	None			Without parity bit
		1	Odd			Odd parity bit
		2	Even			Even parity bit
12	Stop_bits		Selection			Number of stop bits
		0	1			1 stop bit
		1	2			2 stop bits

5.6.2 Read values submenu



Read values table (visible on the user and the operator level)

04: Read_values

No.	Parameter	Adjustment/value range			Meaning/Comment
		Factory setting (FS)	Bold	FS	
		Min	Max		[] explains the term in the glossary ->[] refers to a related explanation of the term
1	Status_unit	Read value			Operating condition of unit
	0	Initialization			Control performs initialisation [10]
	1	Safety_interlock_open			Unit is ready for humidification, but the safety interlock [11] is open.
	2	No_Demand			Unit is ready for humidification, but there is no demand [5].
	3	Humidification			Humidifying [47]
	4	Runtime_limitation			Unit has switched off after limitation of operating time was reached [32]
	5	Remote_off			Unit was switched off via a software command [12] for opening the interlock (safety) system [83] via the communication interface [13]
	6	No_bus-signal			Steam production was switched off manually via the on/off button [14]
	7	Standby_heating_heating			The standby heating [16] is in the heating phase
	8	Standby_heating_interval			The standby heating [16] is in the resting phase
	9	No_demand_ECO			There is no demand [5] in ECO mode [61]
	10	Humidification_ECO			Humidifying in ECO mode [61]
	11	Timer_steam_off			Steam is not produced after the timer [18] has expired
	13	Weekly_timer_steam_off			No steam is produced after the weekly timer has run out
	14	Digital_input_steam_off			Steam production was cut via the digital input [97]
	16	Water_inlet_steam_off			The system does not have enough inlet water pressure and shuts down.
	17	Cooling_no_demand			Unit is ready for cooling, but there is no demand [5]
	18	output_limit_Steam_Off			Device has switched off due to power limitation via external control signal
	45	Fill_delayed			Filling is delayed
	270	Service_message			A service message has appeared. For detailed specification, see read value 8 for cyl. 1 and read value 9 for cyl. 2 (double cylinder units only)
	900	Diagnosis			Unit is performing diagnostics [15]
	901	Not_programmed			The control electronics is not yet programmed for the unit type
	902	Update_in_progress			A USB stick was plugged in and a parameter upgrade is run by the unit
	903	Restart			A parameter upgrade was successfully carried out. Restart of the unit is required
	999	Fault			There is a fault
2	Status_cyl. 1	Read value			Status of cylinder 1
	0	Initialization			Unit is in initialization phase ->[10]
	1	Safety_interlock_open			Cyl. 1 is ready for steam production, but the interlock (safety) system [11] is open
	2	No_Demand			Cyl. 1 is ready for steam production, but there is no demand [5]
	3	Humidification			Humidifying [47]
	30	Filling_valve 1			Filling via solenoid valve 1 [19]
	32	Filling_valve 1 a. 2			Filling via solenoid valve 1 and solenoid valve 2 [19]
	45	Fill_delayed			There is no longer a cylinder full level, refilling is currently delayed
	60	Start_blow-down			At the start of operation, the unit performs a start blow-down [20]
	61	Part_blow-down			A partial blow-down [21] is performed
	62	Full_blow-down			A full blow-down [22] is performed
	63	Dilution			The unit performs a dilution [23] of the cylinder water (only ELDB [77])
	64	Max_current_blow-down			The unit performs an overcurrent blow-down [24] because the measured current is too high (only for ELDB [77])
	65	Max_level_blow-down			The unit performs a max. level blow-down [25] because the water level is too high (only for HKDB [78])
	66	Standby_blow-down			The unit performs a Standby blow-down [26], because the maximum duration without demand [5] has been reached
	67	Dead_leg_flushing			A dead-end line flushing is performed [27]
	68	Manual_blow-down			A manual blow-down [28] was triggered
	81	Part_blow-down_pending			A partial blow-down [21] is performed before the next filling process
	82	Full_blow-down_pending			A full blow-down [22] is performed before the next filling process
	90	Cylinder_full			The sensor electrode reports when the maximum water level in the cylinder has been reached (only for ELDB [77])
	270	Service_message			A service message has appeared. For detailed specification, see read value 8 for cyl. 1 and read value 9 for cyl. 2 (double cylinder units only)
	900	Diagnosis			The unit is in diagnostic mode [15]
	999	Fault			There is a fault

Read value table (ctd.)

No.	Parameter	No.	Adjustment/value range			Meaning/Comment
			Min	Max	FS	
3	Status_cyl. 2			Read value	Status of cylinder 2 (as cylinder 1)	
			see: 04-2	Status_cyl. 1		
4	Fault_message_unit			Read value	List of possible unit fault messages	
			see: 02-1	Fault_message_unit		
5	Fault_message_cyl. 1			Read value	List of possible fault messages for cylinder 1 (see Fault_message_unit)	
			see: 02-2	Fault_message_cyl. 1		
6	Fault_message_cyl. 2			Read value	List of possible fault messages for cylinder 2 (see Fault_message_unit)	
			see: 02-2	Fault_message_cyl. 1		
7	Service_message_unit			Read value	Service message unit	
			see: 02-4	Service_message_unit		
8	Service_message_cyl. 1			Read value	List of service messages for cylinder 1	
			see: 02-4	Service_message_unit		
9	Service_message_cyl. 2			Read value	List of service messages for cylinder 2	
			see: 02-4	Service_message_unit		
10	Steam_actual_unit			Read value	Current steam output of the unit [4] in kg/h	
11	Steam_actual_cyl. 1			Read value	Current steam output [4] of cylinder 1 in kg/h (for double cylinder units)	
12	Steam_actual_cyl. 2			Read value	Current steam output [4] of cylinder 2 in kg/h (for double cylinder units)	
16	Output_max.			Read value	Set value of maximum output power [43]	
17	Demand			Read value	The demand [5] is the control signal from which the internal actuator signal [42] is created	
18	Control_sig_internal			Read value	Internal actuator signal [42] as a percentage of the actuator signal for the nominal output	
19	Control signal_Cyl. 1			Read value	Internal actuator signal [42] as a percentage of the actuator signal for the nominal output	
20	Control signal_Cyl. 2			Read value	Internal actuator signal [42] as a percentage of the actuator signal for the nominal output	
21	Output_signal			Read value	Output signal [69] on terminals 12, 13 proportional to input signal	
22	Safety_interlock			Read value	Status of the interlock (Safety) system [11]	
		0	Off		The interlock (safety) system is open	
		1	On		The interlock (safety) system is closed	
23	Safety_interlock_virtual			Read value	Status of the virtual interlock (safety) system [86]	
		0	Off		The interlock (safety) system is open	
		1	On		The interlock (safety) system is closed	
24	Current_actual_cyl. 1			Read value	The current power consumption of cylinder 1 (only for ELDB [77])	
25	Current_actual_2_cyl. 1			Read value	Rated current of the second transformer of cylinder 1 of the humidifier in A	
26	Current_actual_cyl. 2			Read value	The current power consumption of cylinder 2 (only for ELDB [77] double cylinder units)	
27	Water_level_cyl. 1			Read value	Water level in cylinder 1 in mm (only for HKDB [78])	
28	Water_level_cyl. 2			Read value	Water level in cylinder 2 in mm (only for HKDB [78] double cylinder units)	
33	Model			Read value	Type designation of unit	
34	Unit_name			Read value	Unit name [90], can be selected by the customer, if required	
35	Serial_number			Read value	Serial_number	

Read value table (ctd.)

No.	Parameter	No.	Adjustment/value range			Meaning/Comment [] explains the term in the glossary →[] refers to a related explanation of the term
			Factory setting (FS)	Min	Max	
37	Controller_series				Read value	Type of control
38	Software_version				Read value	Software version of control
39	Humidity_set_value				Read value	Set value [3] of rel. humidity [2] in %
40	Humidity_actual_value				Read value	Actual value [1] of rel. humidity [2] in %
41	Humidity_set_max				Read value	Set value [3] of rel. humidity [2] in % when floating max. limiter [35] is activated
42	Humidity_actual_max				Read value	Actual value [1] of rel. humidity [2] in % whwn floating max. limiter [35] is activated
51	Steam_amount_total_cyl. 1				Read value	Entire steam volume of cylinder 1 [kg] produced since initial operation
52	Steam_amount_total_cyl. 2				Read value	Entire steam volume of cylinder 2 [kg] produced since initial operation (double cylinder units only)
55	V_Signal				Read value	Voltage signal measured on terminal ST0505
56	mA_Signal				Read value	Current signal measured on terminal ST0506
57	Ω_Signal				Read value	Resistance signal measured on terminal ST0507
58	Digital_input				Read value	Actual state of the digital input [97]
		0	Off			No switching signal
		1	On			Switching signal present
59	Nominal_current_cyl. 1				Read value	Nominal current of cylinder 1 of the humidifier in A
60	Nominal_current_cyl. 2				Read value	Nominal current of cylinder 2 of the humidifier in A
74	Unit_total_runtime				Read value	The total runtime of the unit since its first connection to the power supply (specified in days/months/years/hours/minutes)
75	Production_total_time				Read value	Total duration of steam production since initial operation (specified in days/months/years/hours/minutes)

The parameterisation of the humidity_set-point or humidity_actual value is only available when the PI controller is activated (see parameter Commissioning: 01-4).

5.6.3 History submenu



This submenu is identical on the user and the operator level.

Table of history layout

5.6.3.1 Explanation of history management

The control stores 10 sets of error messages on a rolling basis. Once there are 10 records, the oldest record is overwritten by a current entry. An error message set consists of the following entries:

1. Date of error message
2. Contents of error message
3. Frequency of error message
4. Error origin

If an identical error occurs several times in a row, the first entry relating to this error is updated with the date of the most recent occurrence and the frequency is incremented. A new error message set is not recorded.

The situation is different if a particular error occurs multiple times, but not in direct succession. In this case, a new error message set is written for each instance.

07: History

No.	Parameter	No.	Adjustment/value range			Meaning/Comment [] explains the term in the glossary →[] refers to a related explanation of the term
			Factory setting (FS)	Min	Max	
1	1st fault_entry_date				Read value	1. Memory entry: Date/time
2	1st fault_entry_message				Read value	1. Memory entry: Fault message (for explanation see Read values 4 / Fault_message_unit)
					see: 02-1 Fault_message_unit	
3	1st fault_entry_rate				Read value	1. Memory entry: Frequency of occurrence (since initial operation)
4	1st fault entry				Read value	1st memory entry: source of occurrence
		0	-			is not known
		1	Mainboard			is the motherboard
		2	Cylinder 1			is the steam cylinder 1
		3	Cylinder 2			is the steam cylinder 2
		4	Humidifier			is the humidifier
		20	Cylinder_extension 1			is the expansion board 1
5	2nd fault_entry_date				Read value	2. Memory entry: Date/time
6	2nd fault_entry_message				Read value	2. Memory entry: Error message, see above
					see: 02-1 Fault_message_unit	
7	2nd fault_entry_rate				Read value	2. Memory entry: Frequency of occurrence (since initial operation)
8	2nd fault entry				Read value	2nd memory entry: source of occurrence
					see: 07-4 1st fault entry	
9	3rd fault_entry_date				Read value	3. Memory entry: Date/time
10	3rd fault_entry_message				Read value	3. Memory entry: Error message see above
					see: 02-1 Fault_message_unit	
11	3rd fault_entry_rate				Read value	3. Memory entry: Frequency of occurrence (since initial operation)
12	3rd fault entry				Read value	3rd memory entry: source of occurrence
					see: 07-4 1st fault entry	
13	4th fault_entry_date				Read value	4. Memory entry: Date/time
14	4th fault_entry_message				Read value	4. Memory entry: Error message see above
					see: 02-1 Fault_message_unit	
15	4th fault_entry_rate				Read value	4. Memory entry: Frequency of occurrence (since initial operation)

Table of history layout (ctd.)

No.	Parameter	No.	Adjustment/value range			Meaning/Comment
			Min	Factory setting (FS) Bold Max	FS	
16	4th fault entry			Read value		4th memory entry: source of occurrence
17	5th fault_entry_date		see: 07-4	1st fault entry Read value		5. Memory entry: Date/time
18	5th fault_entry_message			Read value		5. Memory entry: Error message see above
19	5th fault_entry_rate		see: 02-1	Fault_message_unit Read value		5. Memory entry: Frequency of occurrence (since initial operation)
20	5th fault entry			Read value		5th memory entry: source of occurrence
21	6th fault_entry_date		see: 07-4	1st fault entry Read value		6. Memory entry: Date/time
22	6th fault_entry_message			Read value		6. Memory entry: Error message see above
23	6th fault_entry_rate		see: 02-1	Fault_message_unit Read value		6. Memory entry: Frequency of occurrence (since initial operation)
24	6th fault entry			Read value		6th memory entry: source of occurrence
25	7th fault_entry_date		see: 07-4	1st fault entry Read value		7. Memory entry: Date/time
26	7th fault_entry_message			Read value		7. Memory entry: Error message see above
27	7th fault_entry_rate		see: 02-1	Fault_message_unit Read value		7. Memory entry: Frequency of occurrence (since initial operation)
28	7th fault entry			Read value		7th memory entry: source of occurrence
29	8th fault_entry_date		see: 07-4	1st fault entry Read value		8. Memory entry: Date/time
30	8th fault_entry_message			Read value		8. Memory entry: Error message see above
31	8th fault_entry_rate		see: 02-1	Fault_message_unit Read value		8. Memory entry: Frequency of occurrence (since initial operation)
32	8th fault entry			Read value		8th memory entry: source of occurrence
33	9th fault_entry_date		see: 07-4	1st fault entry Read value		9. Memory entry: Date/time
34	9th fault_entry_message			Read value		9. Memory entry: Error message see above
35	9th fault_entry_rate		see: 02-1	Fault_message_unit Read value		9. Memory entry: Frequency of occurrence (since initial operation)
36	9th fault entry			Read value		9th memory entry: source of occurrence
37	10th fault_entry_date		see: 07-4	1st fault entry Read value		10. Memory entry: Date/time
38	10th fault_entry_message			Read value		10. Memory entry: Error message see above
39	10th fault_entry_rate		see: 02-1	Fault_message_unit Read value		10. Memory entry: Frequency of occurrence (since initial operation)
40	10th fault entry			Read value		10th memory entry: source of occurrence
42	1. Service_entry_date			0 65535 0		1. Memory entry: Date/time
43	1. Service_entry_notification			Selection		1. Memory entry: Service message (for explanation see Read values 4 / Service_message_unit)
44	1. Service_entry_number			see: 02-4 0 255 0		1. Memory entry: Frequency of occurrence (since initial operation)

Table of history layout (ctd.)

No.	Parameter	No.	Adjustment/value range			Meaning/Comment [] explains the term in the glossary →[] refers to a related explanation of the term
			Factory setting (FS) Bold			
			Min	Max	FS	
48	2. Service_entry_number		0	255	0	2. Memory entry: Frequency of occurrence (since initial operation)
49	2nd service entry		Selection			2nd memory entry: source of occurrence
			see: 07-45 1st service entry			
50	3. Service_entry_date		0	65535	0	3. Memory entry: Date/time
51	3. Service_entry_notification		Selection			3. Memory entry: Service message, see above
			see: 02-4 Service_message_unit			
52	3. Service_entry_number		0	255	0	3. Memory entry: Frequency of occurrence (since initial operation)
53	3rd service entry		Selection			3rd memory entry: source of occurrence
			see: 07-45 1st service entry			
54	4. Service_entry_Date		0	65535	0	4. Memory entry: Date/time
55	4. Service_entry_notification		Selection			4. Memory entry: Service message, see above
			see: 02-4 Service_message_unit			
56	4. Service_entry_number		0	255	0	4. Memory entry: Frequency of occurrence (since initial operation)
57	4th service entry		Selection			4th memory entry: source of occurrence
			see: 07-45 1st service entry			
58	5. Service_entry_Date		0	65535	0	5. Memory entry: Date/time
59	5. Service_entry_notification		Selection			5. Memory entry: Service message, see above
			see: 02-4 Service_message_unit			
60	5. Service_entry_number		0	255	0	5. Memory entry: Frequency of occurrence (since initial operation)
61	5th service entry		Selection			5th memory entry: source of occurrence
			see: 07-45 1st service entry			
62	6. Service_entry_Date		0	65535	0	6. Memory entry: Date/time
63	6. Service_entry_notification		Selection			6. Memory entry: Service message, see above
			see: 02-4 Service_message_unit			
64	6. Service_entry_number		0	255	0	6. Memory entry: Frequency of occurrence (since initial operation)
65	6th service entry		Selection			6th memory entry: source of occurrence
			see: 07-45 1st service entry			
66	7. Service_entry_Date		0	65535	0	7. Memory entry: Date/time
67	7. Service_entry_notification		Selection			7. Memory entry: Service message, see above
			see: 02-4 Service_message_unit			
68	7. Service_entry_number		0	255	0	7. Memory entry: Frequency of occurrence (since initial operation)
69	7th service entry		Selection			7th memory entry: source of occurrence
			see: 07-45 1st service entry			
70	8. Service_entry_Date		0	65535	0	8. Memory entry: Date/time
71	8. Service_entry_notification		Selection			8. Memory entry: Service message, see above
			see: 02-4 Service_message_unit			
72	8. Service_entry_number		0	255	0	8. Memory entry: Frequency of occurrence (since initial operation)
73	8th service entry		Selection			8th memory entry: source of occurrence
			see: 07-45 1st service entry			
74	9. Service_entry_Date		0	65535	0	9. Memory entry: Date/time
75	9. Service_entry_notification		Selection			9. Memory entry: Service message, see above
			see: 02-4 Service_message_unit			
76	9. Service_entry_number		0	255	0	9. Memory entry: Frequency of occurrence (since initial operation)

5.7 Screen 3 - Main menu (operator level)

After the operator level has been selected by entering the corresponding password (code 010), the main menu is displayed. It spans multiple screen pages and scroll keys are used to navigate between them.

Screen page 1 (of 3)

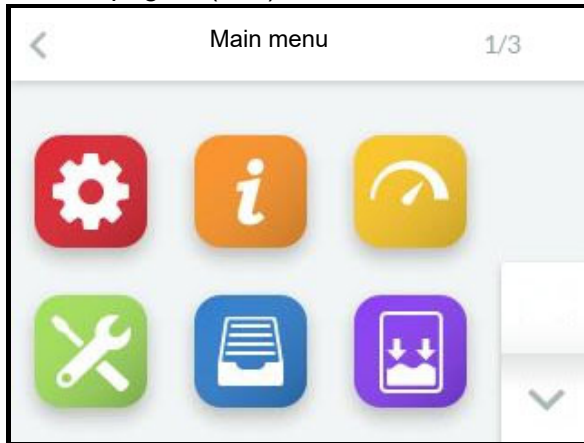

Screen page 2 (of 3)

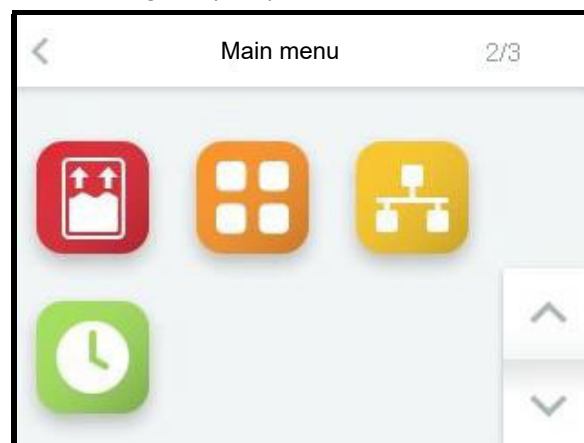

Screen page 3 (of 3)

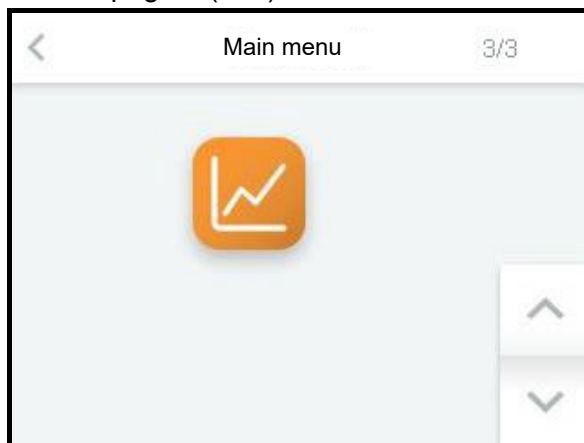

5.8 Operator level submenus

By touching the respective icon, the operator accesses the screen page where the parameters of the respective group are available for selection, viewing or for making changes. The layout of the screen pages corresponds to the pages of the submenus of the user level (see Section 5.6).

Icon	Selection of submenu
	Settings
	Read values
	Control
	Service
	History
	Blow-down
	Filling
	Functions
	Communication interface
	Weekly timer
	Recording
	Cylinder extension (visible only if an extension board is present)
	Relay extension 1 (visible only if a relay board is present)
	Relay extension 2 (visible only if 2nd relay board is present)
	TPRO (only visible with steam humidifiers with a TPRO version)

The parameters available in the submenus are described in table form below (for explanations on the individual parameters see Glossary in Section 8).

5.8.1 Settings submenu

Table of settings parameters (operator level)



03: Settings

No.	Parameter	No.	Adjustment/value range			Meaning/Comment
			Min	Max	FS	
1	Language		Selection Factory setting (FS) Bold see: 01-1 Language			Selection of language
2	Date		DD.MM.YY			Set date
3	Time_of_day		HH:MM			Set time
4	Display_lighting_normal		50	100	100	Screen backlight in undimmed state
5	Delay_present_page		0	3600	300	Display duration for a certain screen page before return to the main screen in min
6	Display_lighting_dimmed		30	100	50	Screen brightness for dimmed state
7	Display_dim_after		0	3600	120	Switching of screen brightness of main screen to dimmed value after ... seconds. If an error has occurred or a status message is displayed, the main screen is not dimmed
8	Units	0 1	Selection SI Imperial			Selection of system of units Units are displayed in the format of the SI system of units [8] Units are displayed in the format of the imperial system of units [9]
9	Address		0	255	1	Address of the communication interface of display [13]
10	Baud_rate	3 4 6	Selection 9600 19200 38400			Setting the baud rate 9600 19200 38400
11	Parity	0 1 2	Selection None Odd Even			Parity setting Without parity bit Odd parity bit Even parity bit
12	Stop_bits	0 1	Selection 1 2			Number of stop bits 1 stop bit 2 stop bits

Settings in baud rate, parity and stop bits are only available in connection with an RS485 display.

5.8.2 Read values submenu



The read value submenu is no different to that of the user level. The read values listed in table format in Section 5.6. are also available at the operator level.

5.8.3 Control submenu



Table of control parameters

05: Control

No.	Parameter	No.	Adjustment/value range			Meaning/Comment [] explains the term in the glossary → [] refers to a related explanation of the term
			Min	Max	Factory setting (FS) Bold	
1	Control_settings		Selection see: 01-4 Control_settings			Combinations of control type and input signal type/range
2	Output_max.		25,0	100,0	100,0	The maximum output power [43] can be limited to between 25 and 100%
3	Δ Power_limitation		0,0	100,0	0,0	Reduction of the max. humidification output for the purpose of load shedding [101].
4	Output_signal		Selection			Mapping of the output signal [69] to an internal value
		0	Off			No mapping
		1	Control_sig_external			Output signal is proportional to the demand [5] from the external controller [73]
		2	Control_sig_internal			Output signal is proportional to the internal actuator signal [42]
		3	Humidity_actual_value			Output signal is proportional to the actual humidity value [1]
		4	Control_signal_slave			Step signal for retrofit kit HL and HC
		5	Control_signal_controller			Output signal is proportional to the demand [5] from internal PI controller [96]
17	Humidity_set_value		0,0	99,0	50,0	Set value [3] of RH [2] in %
18	Δ Set_value_dehumidification		1,0	20,0	10,0	Downstream dehumidifier is actuated if humidity set value has been exceeded by the respective difference value [%], (PI controller only), → [50]
19	Δ Humidity_ECO		0,0	50,0	10,0	Target humidity is lowered by this percentage when ECO is switched on
20	PI-controller_gain		0,5	100,0	5,0	Proportional part of PI controller
21	PI-controller_integral		0	100	10	Integral part of PI controller
22	Humidity_notification		5,0	99,0	50,0	When the set humidity [%] has been reached, one of the relays is energised, which must have been assigned code 211 (humidity reached) for this purpose
23	Humidity_set_max		5,0	99,0	80,0	Specification of max. humidity for the switch-off point when using the floating max. limiter [35]
24	Pi-controller_max_gain		0,5	100,0	5,0	Amplification of 2nd PI controller when using the floating max. limiter [35]
33	Damping_analog_inputs		Selection			The attenuation for capacitive sensors is activated. Only possible with activated PI controller
		0	Off			Switch off attenuation
		1	On			Switch on attenuation

5.8.4 Service submenu



5.8.4.1 Monitoring and service messages

The wear components of the unit and the status of the steam cylinder(s) are monitored continuously when the unit is in operation. When a limit value is reached, the corresponding service message is displayed with reference to the cylinder. The service messages need to be reset after component replacement or cylinder maintenance.

The following **service messages** are implemented:

Steam volume

A steam volume in kg is specified in the "Steam_volume_service" parameter and after this is reached, the message "Steam volume counter" is issued. In case of double cylinder units, the parameter entry applies to both cylinders. The service message differentiates between cylinder 1 and cylinder 2.

After the service has been carried out, the message has to be reset with "Reset_cyl. 1" or "Reset_cyl. 2" (or both).

For the assessment of the remaining steam volume until the next service is required, the read values "Steam_volume_to_service_cyl. 1" and "Steam_volume_to_service_cyl. 2" (only for double cylinder units) are used.

Main contactors

For main contactors, the maximum number of operating cycles is specified by the manufacturer. When a limit value is reached, the corresponding service message is displayed. The main contactor must then be changed and the message has to be reset by setting the "Main_contactor Kx_Reset" (x = 1...5) parameter.

Please note

When the service message was triggered for one of the main contactors, it is advisable to check the meter reading for the remaining main contactors.

Monitoring

The FlexLine control permanently monitors the performance capabilities of the electrodes (ELDB only), of the blow-down pump(s), and of the solenoid valve(s). When preset functionality warning thresholds are exceeded, messages are generated with respect to the current state of:

- Electrodes (ELDB only), („Warning_cyl._full“)
- Blow-down pump(s) („Warning_pump“)
- Solenoid valve(s) („Warning_valve“)

Three sensitivity values can be selected for each of the alarm thresholds, where "Sensitivity 3" triggers the warning messages at the earliest time.

After the condition for triggering the warning has been resolved (e.g. by cleaning the solenoid valve intake strainer), no further warning is issued. The warning messages can also be turned off (s. parameters 22, 23 and 24 in the table following hereunder).

Table of service parameters

06: Service

No.	Parameter	No.	Adjustment/value range			Meaning/Comment [] explains the term in the glossary →[] refers to a related explanation of the term
			Min	Max	FS	
1	Steam_amount_service		0	65535	4500	Preset steam volume (see [33]) in kg until service message is triggered. For double cylinder units, this setting applies to both cylinders
4	Service-reset_cyl. 1		Selection			Reset steam volume counter for cylinder 1 →[33]
		0	Off			No
		1	On			Yes
5	Steam_until_msg_cyl. 1		Read value			Remaining steam volume for cyl. 1 in kg until service message →[33] is triggered
7	Service-reset_cyl. 2		Selection			Reset steam volume counter for cylinder 2 →[33], double cylinder units only
		0	Off			No
		1	On			Yes
8	Steam_until_msg_cyl. 2		Read value			Remaining steam volume for cyl. 2 in kg until service message →[33] is triggered
12	Main_contactor 1_reset		Selection			Reset K1 counter for main contactor operating cycles →[34]
		0	Off			No
		1	On			Yes
13	K1_switching_cycles_until_msg.		Read value			Remaining operating cycles for K1 until service message →[34] is triggered
22	Warning_cyl._full		Selection			Warning message about electrode burn-off (only for ELDB [77]) →[95]
		0	Off			No message
		1	Sensitivity 1			Threshold value 1 for message (lowest sensitivity)
		2	Sensitivity 2			Threshold value 2 for message (medium sensitivity)
		3	Sensitivity 3			Threshold value 3 for message (highest sensitivity)
23	Warning_pump		Selection			Warning message about functional performance of blow-down pump →[95]
		see: 06-22 Warning_cyl._full				
24	Warning_valve		Selection			Warning message about functional performance of solenoid valves →[95]
		see: 06-22 Warning_cyl._full				
26	Update_function		Read value			Status of update function [7]
		0	USB-stick_insert			USB stick is not inserted
		1	Loading			The parameter set which is saved on the stick is loaded
		2	Checking			The loaded parameter set is checked
		3	Update			The parameter set is updated
		4	Successful			The update was successful
		5	Data_not_valid			USB stick does not contain a parameter set or parameter set is not compatible

5.8.4.2 Procedure for parameter update

The information below explains how to work with the "Update_function" parameter (see parameter row 26 in the table above).

The update function makes it possible to overwrite parameter settings with a parameter set which is saved on an external USB flash drive. As a result, the operator can make a change without having to change the parameters by themselves. The modified parameter set can be provided by HygroMatic.

The procedure is as follows:

- » With the unit switched on, insert the USB stick into the socket on the mainboard.
- » Call up the "Update function" in the services submenu.

The status of the update process is displayed (see table). Its successful completion is displayed by the "Update successful" status message.

- » Switch the unit off and on again. The loaded parameter set is activated.
- » To reload the parameter set at a later date if required (e.g. after a factory reset), the "ImportDone.txt" file on your USB stick must be deleted beforehand. To do so, the stick must be inserted in an external device (e.g. PC).

If the status "Invalid data" is output after the update operation, a compatible parameter set is not available on the USB stick.

The parameter set that is stored on a USB stick is always linked with a unit serial number and can only be used for this unit.

USB connector on mainboard

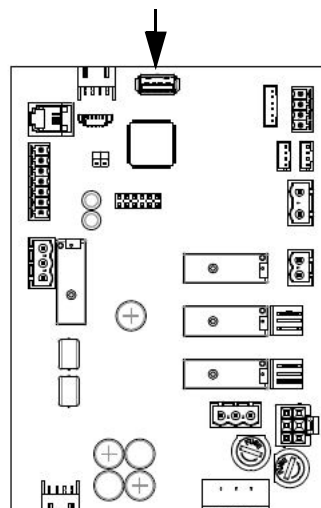

5.8.5 History submenu



The error message history was already described for the user level in Section 5.6.3. There are no differences at the operator level.

5.8.6 Blow-down submenu



Table of blow-down parameters

08: Blow-down

No.	Parameter	No.	Adjustment/value range			Meaning/Comment [] explains the term in the glossary →[] refers to a related explanation of the term
			Min	Max	FS	
1	Full_blow-down_correction		-5	5	0	Correction value for frequency of full blow-down (+ = more frequently, - = less frequently) →[55]
2	Part_blow-down_correction		-5	5	0	Correction value for frequency of partial blow-down (+ = more frequently, - = less frequently) →[55]
5	Standby_blow-down		Selection			Full blow-down [58] for hygiene reasons, if there was no steam production for an extended period →[26]
		0	Deactivated			No stand-by blow-down
		1	Waiting time			Sludge removal after the waiting time set with parameter 08/4
		2	Time_of_day			Sludge removal after waiting time and at the time specified with parameter 08/19
6	Standby_blow-down_interval		1	2880	1440	After the set waiting time [min], the residual water is drained out if no steam production has taken place →[26].
7	Blow-down_without_K1		Selection			Pumps without main contactor [75] in order to avoid triggering of residual current detector →[56]
		0	Deactivated			Main contactor [75] switched on during pumping
		1	Activated			Main contactor [75] switched off during pumping
21	Standby_completion_time		00:00	23:59	00:00	Time setting for the execution of the hygiene flush

5.8.7 Fill parameters submenu



Table of fill parameters

09: Filling

No.	Parameter	No.	Adjustment/value range			Meaning/Comment [] explains the term in the glossary →[] refers to a related explanation of the term
			Min	Max	FS	
1	Filling_pulsed		Selection			The filling process is not continuous, but intermittent →[54]
		0	Deactivated			Activated
		1	Activated			Not activated
2	Filling_pulsed_interval		1	25	2	Time interval in s, during which filling does not take place (filling pause)
3	Filling_pulsed_active		1	600	10	Duration of filling time in s until filling pause

5.8.8 Functions submenu



Table of functions parameters

10: Functions

No.	Parameter	No.	Adjustment/value range			Meaning/Comment
			Min	Max	FS	
1	Standby-heating		Selection			The standby heating [16] keeps the water in the cylinder warm if no demand [5] is present
		0	Deactivated			Standby heating [16] switched off
		1	Activated			Standby heating [16] switched on
		2	Pi-controller			Standby heating [16] is in temperature control mode (only TPRO)
2	Standby-heating_interval		1	999	1	Pause time of standby heating [min]
3	Standby-heating_active		1	999	1	Heating time of standby heating [16] [s]
9	Dead_leg_flushing		Selection			Solenoid valve of the water inlet and pump/flushing valve are switched on and off in parallel for dead leg flushing [27].
		0	Deactivated			Flushing of dead-end line [27] is not carried out
		1	Activated			Perform dead leg flushing [27] as required (semi-automatic or fully automatic, depending on device/plant)
10	Dead_leg_flushing_interval		1	5760	1440	Waiting period until start of flushing of dead-end line [27] [min]
11	Dead_leg_flushing_active		1	600	90	Duration of flushing of dead-end line [27] [s]
12	Runtime_limitation		0	1440	0	Steam production is stopped after the time interval specified [min]; for resumption →[32]
13	Weekly_timer		Selection			Activation of weekly timer
		0	Off			Steam production runs continuously with the parameters preset
		1	On			Steam is generated in accordance with the settings made in the weekly timer submenu →[91]
14	Timer_mode		Selection			The timer function [18] is triggered with an external button
		0	Off			The timer function [18] is not available
		1	Steam_off			Steam production stops after the timer has elapsed
		2	ECO			The unit reverts to ECO mode [61] after the timer has elapsed
15	Timer_running_time		0	65535	0	The runtime of the timer is given in seconds
16	Password_remote		0	9999	0	Storage of a password with a maximum of 4 digits for remote access via the communication interface, input using the keyboard screen
17	Function_digital_input		Selection			Mapping of digital input function [98] to mainboard
		0	Off			Not used
		11	ECO_HVAC			Activated digital input [97] by a pushbutton [106] switches ECO mode on
		30	Timer_start			Activated digital input [97] by a pushbutton [106] starts timer function [18]
		40	Power_limitation			Activated digital input [97] by a switch (NO) switches power limitation on for load shedding [101]
		62	Service_shutdown			Activated digital input [97] triggered by external contact
		63	Service_hygrostat			Activated digital input [97] triggered by external contact
		64	Service_airflow			Activated digital input [97] triggered by external contact
		65	Service_leakage			Activated digital input [97] triggered by external contact
		70	Steam_release			The activated digital input[97] by means of a switch (NO)[102] enables steam production. Opening the switch interrupts steam production.
		80	Standby_blow-down			The digital input [97] activated with a button [106] starts a standby desludging process.
		81	Dead_leg_flushing			The digital input [97] activated with a button [106] starts a stub flush.
		90	Relay			The digital input [97] activated by a switch (NO) [102] activates a relay if this has been assigned.
		100	Water inlet pressure			The activated digital input [97] monitors the (NC) contact of the water inlet pressure switch in adiabatic systems. If the contact opens, a fault and service message is shown in the display.
		101	Blowdown_delay			The activated digital input [97]: a button [106] is used to delay a blow-down in progress.

Function parameters (ctd.)

No.	Parameter	No.	Adjustment/value range			Meaning/Comment
			Factory setting (FS)	Bold	FS	
21	Control_curve		Min	Max		Behaviour during cold start or specification for special applications (only ELDB [77]), see [68]
		0				Current during cold start is 128% of rated current for fast heating
		1				Current during cold start is 113% of the nominal current, to avoid overloading the supply network despite fast heating
		2				Particularly fine control for critical applications
22	Delay_humidificat._notif.		0	3600	60	Delay of Humidifying message [s] →[74]
23	Assignment_main_relay					The relay is energised for a message (M) or a switching function (S), if ...
		0				Collective_fault There is any kind of error (M)
		1				Safety_interlock_open The interlock (safety) system [11] is open (M)
		2				No_Demand No demand [5] is present (M)
		3				Humidification Steam production is in progress (M)
		4				Runtime_limitation The unit has switched off steam production after the limitation of operating time was reached [32] (M)
		5				Remote_off A remote shutdown was carried out via software command [12] (M)
		6				Safety_interlock_ELV The interlock (safety) system [11] is switched via an additional relay (M)
		7				Safety_interlock_closed The interlock (safety) system [11] is switched as standard (M)
		8				Humidification_off_delay A dropout delay [74] is to be generated following humidification (S)
		9				Timer_steam_off the timer function has stopped the steam production (M)
		10				Weeckly_timer_steam_off the weekly timer has stopped the steam production (M)
		11				Modbus it is controlled directly by a Modbus command. (S)
		12				Standby_signal the device has completed initialization and is not in error (M)
		13				Initialization Unit is in initialization
		19				Timer_Steam_on Timer gives the signal for steam release
		20				Digital_input_active the digital input of the motherboard is activated (M)
		23				DigIn_EB the digital input of the expansion board is activated (M)
		24				Digital_Ohm_active Resistance input of the motherboard as digital input is activated (M)
		27				DigIn_Ohm_EB Resistance input of the expansion board as digital input is activated (M)
		30				Soleniod_valves_off None of the solenoid valves are actuated (M)
		31				Soleniod_valves_on One of the solenoid valves is actuated (M)
		32				Soleniod_valve_1 Solenoid valve 1 is actuated (M)
		38				Pressure_water_input_min the minimum water inlet pressure is not reached.
		60				Pump_off the blowdown pump is not activated (M)
		61				Pump_on The blow-down pump is actuated (M)
		62				Part_blow-down A partial blow-down [21] is taking place (M)
		63				Full_blow-down A full blow-down [22] is taking place (M)
		64				Dilution A dilution [23] is taking place (only for ELDB [77]) (M)
		65				Max_current_blow-down An overcurrent blow-down [24] is taking place (only for ELDB [77]) (M)
		66				Max_level_blow-down A max. level blow-down [25] is taking place (only for HKDB [78]) (M)
		67				Standby_blow-down A standby blow-down [26] is taking place (M)
		68				Dead_leg_flushing An additionally installed relay is to be actuated, which switches the input solenoid valve for flushing the dead-leg line if the interlock (safety) system is not closed (S)
		69				Start_blow-down A start blow-down [20] is taking place (M)
		70				Blowdown_cycle blow-down [20..26] takes place.
		90				Cylinder_full_cyl. 1 Cylinder 1 is pending full.
		91				Cylinder_full_cyl. 2 Cylinder 2 is pending.
		120				Cylinder_1_step_1 Power level [63] 1 of cylinder 1 is active (only for HKDB [78]) (S). If this assignment was chosen ex-factory, no other assignment is possible.
		121				Cylinder_1_step_2 Power level [63] 2 of cylinder 1 is active (only for HKDB [78]) (S). If this assignment was chosen ex-factory, no other assignment is possible.
		122				Cylinder_2_step_1 Power level [63] 1 of cylinder 2 is active (only for HKDB double cylinder units) (S). If this assignment was chosen ex-factory, no other assignment is possible.

Function parameters (ctd.)

No.	Parameter	No.	Adjustment/value range			Meaning/Comment
			Min	Max	FS	
		123	Cylinder_2_step_2			Power level [63] 2 of cylinder 2 is active (only for HKDB double cylinder units) (S). If this assignment was chosen ex-factory, no other assignment is possible.
		124	Dry_level_cyl. 1			Dry cycle of cylinder 1 is pending.
		125	Dry_level_cyl. 2			Dry cycle of cylinder 2 is pending.
		126	Cylinder_1_stage_1_2			Main contactor K1.2 is actuated at ELDB.
		127	Cylinder_1_Step2_2			Main contactor K2.2 is triggered on ELDB.
		210	Dehumidification			A downstream dehumidifier is to be actuated →[50] (S)
		211	Humidity_reached			The value set in the Control 21 parameter (Humidity_notification) has been reached (M)
		212	Steam_valve			Steam valve on steam outlet is controlled
		270	Collective_service			A general service message is generated (M)
		271	Service_solenoid_valve			A service for one of the solenoid valves or the water supply line is required
		272	Service_blow-down_pump			A service for the blow-down pump is required (M)
		273	Service_steam_amount_cnt.			A service is required after the steam volume counter which is relevant for the service was reached (M)
		274	Service_main_contactor K1			A service is required after the max. operating cycles for K1 have been reached (M)
		284	Not_used			The relay is not used and is not controlled.
24	Assignment_relay K20		Selection			Relay 1 is one of the top-hat rail relays connected to the ST10.1 connector on the mainboard; assignment is same as for base relay
			see: 10-23 Assignment_main_relay			
25	Assignment_relay K21		Selection			Relay 2 is the second of the top-hat rail relays connected to the ST10.2 connector on the mainboard; assignment is same as for base relay
			see: 10-23 Assignment_main_relay			
26	Assignment_relay K22		Selection			Relay 3 is one of the top-hat rail relays connected to the ST10.2 connector on the mainboard; assignment is same as for base relay
			see: 10-23 Assignment_main_relay			
27	Assignment_relay K23		Selection			Relay 4 is the second of the top-hat rail relays connected to the ST10.2 connector on the mainboard; assignment is same as for base relay
			see: 10-23 Assignment_main_relay			
34	Filling_Mode		Selection			Fill hysteresis for smaller quantities
			see: 10-21 Control_curve			

Relay K20 to K23/ Relay assignment ex works.

If there are no factory installed options, only contact ST03 on the basic relay is assigned the "collective fault" function.

The switching message "Not used" is assigned to all other contacts.

5.8.9 Communication interface sub-menu



The communication interface is a serial RS285 computer interface for the remote control of the steam humidifier. With this computer interface, all control operations which can be carried out on the screen can also be carried out by the building technology control system, for example.

The MODBUS-RTU Protocol is used to transmit the control commands (separate documentation on this is available from HygroMatik).

Table of communication interface parameters

11: Communication

No.	Parameter	No.	Adjustment/value range			Meaning/Comment [] explains the term in the glossary ->[] refers to a related explanation of the term
			Min	Max	Factory setting (FS) Bold FS	
1	Address		0	255	1	Address of the communication interface [13]
2	Baud_rate		Selection see: 03-10 Baud_rate			Setting the baud rate
3	Parity		Selection see: 03-11 Parity			Parity setting
4	Stop_bits		Selection see: 03-12 Stop_bits			Number of stop bits
5	Modbus_timeout		0	60	20	Timeout in s for software control commands [12] through communication interface [13]
6	BACnet_MacID		1	127	1	Physical address of a BACnet device within the network (s. separate HygroMatik documentation)
7	BACnet_Instance		0	65535	1	Number for the unique addressing of an instance of a specific BACnet object (s. separate HygroMatik documentation)
8	BACnet_Master_max		1	127	127	Specification of the max. qty. of BACnet master devices within the network for avoidance of unnecessary polling actions (s. separate HygroMatik documentation)

5.8.10 Weekly timer submenu



The weekly timer is used to program two switching time ranges per day of the week, each defined by "Start time" and "End time". A humidity target value can be assigned to each switching time range.

Weekly timer activation is accomplished in the „Functions“ submenu by setting parameter no. 8 (weekly timer). Allowable settings are „On“ and „Off“.

Please note

If the control is operated using the internal PI-controller and in weekly timer mode, the humidity set value display in the main view is blanked during normal steam production. When ECO mode is set, however, the humidity set value is still visible.

Table of "Weekly timer" parameters

12: Weekly_timer

No.	Parameter	No.	Adjustment/value range			Meaning/Comment [] explains the term in the glossary →[] refers to a related explanation of the term
			Min	Max	FS	
1	Mon_start_time 1		00:00	23:59	00:00	Start time 1 for Monday (1st period) →[91]
2	Mon_stop_time 1		00:00	23:59	00:00	End time 1 for Monday
5	Mon_humidity_set_value 1		5,0	99,0	50,0	Humidity set value [% RH] for the 1st period on Monday
6	Mon_start_time 2		00:00	23:59	00:00	Start time 2 for Monday (2nd period) →[91]
7	Mon_stop_time 2		00:00	23:59	00:00	End time 2 for Monday
10	Mon_humidity_set_value 2		5,0	99,0	50,0	Humidity set value for the 2nd period on Monday

The table only shows the possible parameter settings for Monday. The parameters for the rest of the weekdays (Tuesday to Sunday) can be programmed in the same way.

The complete record [93] can be saved to a USB stick with FAT32 formatting.

5.8.11 Recording submenu



The control can record 10 data sets internally on a rolling basis (Recording submenu, parameter 1 set to „On“). Snapshots of the unit status are carried out at intervals of 10 s, which can be helpful for troubleshooting. When all memory slots are filled, a new set of data overrides the oldest entry. A recorded set of data is conserved for a period of max. 7 days.

For saving, pls. proceed as follows:

- » Call up recording submenu.
- » Insert USB stick in connector on mainboard (s. drawing below).
- » Set parameter „Saving_start“ (2) to „On“. Saving starts automatically. Then, parameter „Saving_start“ returns to the „Off“-state.

USB connector on mainboard

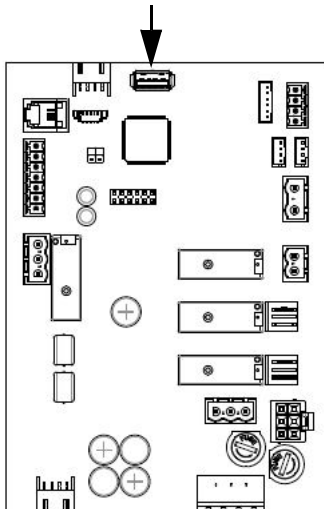

A data set consists of the following values:

No.	Value	only
1	Steam_actual unit	
2	Steam_actual_Cyl. 1	DZG
3	Steam_actual_Cyl. 2	DZG
4	Status_unit	
5	Status_cyl. 1	
6	Status_cyl. 2	DZG
7	Fault message_unit	
8	Fault message_cyl. 1	
9	Fault message_cyl. 2	DZG
10	Safety interlock_open	
11	Demand	
12	Steam_output_max.	
13	Current_actual_Cyl. 1	ELDB
14	Current_actual_Cyl. 2	ELDB DZG
15	Water_level_cyl. 1	HKDB
16	Water_level_cyl. 2	HKDB DZG
17	Humidity_actual value	
18	Humidity_set value	
19	Humidity_actual_value_max	MB
20	Humidity_set_value_max	MB

Legend:

ELDB = Electrode Steam Humidifier
 HKDB = Heater Element Steam Humidifier
 DZG = Double Cylinder Unit
 MB= Variable Max. Limitation

By looking at parameter „Saving_status“ (4) the status of the saving procedure can be checked. „Activated“ means that writing to the memory stick is underway.

Erasing of the complete memory is achieved by setting the „Recording_delete“ parameter (5) to „On“.

Please note

During the erasing of the recording memory, the display possibly shows a „?“ since no access to the unit parameters is made.

Table of recording functions

16: Recording

No.	Parameter	No.	Adjustment/value range Factory setting (FS) Bold Min Max FS	Meaning/Comment [] explains the term in the glossary →[] refers to a related explanation of the term
1	Recording	0	Deactivated	Recording [93] of parameter sets No recording
		1	Activated	Start recording
2	Saving_start		Selection	Saving of the existing recording on a USB stick
		0	Off	No action
		1	On	Start saving process
3	Saving_abort		Selection	Cancel saving
		0	Off	No action
		1	On	Cancel saving process
4	Saving_status		Read value	Status of saving process
		0	Deactivated	Saving not possible
		1	Activated	Saving is enabled
5	Recording_delete		Selection	Delete recording
		0	Off	No action
		1	On	Delete recording

5.8.12 Cylinder extension submenu



The icon is only visible in the main menu if a cylinder extension board is present.

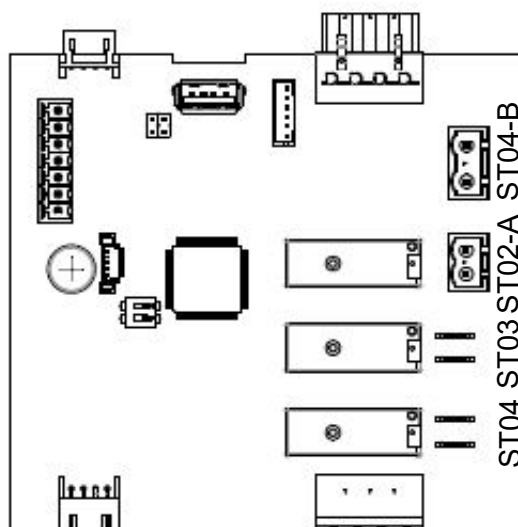

Table of control input parameters

17: Cylinder_extension

No.	Parameter	No.	Adjustment/value range			Meaning/Comment
			Factory setting (FS)	Bold		
			Min	Max	FS	[] explains the term in the glossary →[] refers to a related explanation of the term
1	Digital_input_function		Selection			Assignment of the digital input function [98] of the digital input [97] on the cylinder extension board
			see: 10-17 Function_digital_input			
10	V_Signal		Read value			Voltage signal measured on terminal ST0505
11	V_Signal_%		Read value			Processed input signal corresponding to measured voltage signal on terminal ST0505 [%]
12	mA_Signal		Read value			Current signal measured on terminal ST0506
13	mA_Signal_%		Read value			Processed input signal corresponding to measured current signal on terminal ST0506 [%]
14	Ω_Signal		Read value			Resistance signal measured on terminal ST0507
15	Ω_Signal_%		Read value			Processed input signal corresponding to measured resistance signal on terminal ST0507 [%]
16	Temp.-Signal		Read value			Temperature signal measured on terminal ST0507
17	Digital_input		Read value			Actual state of the digital input [97]
		0	Off			No switching signal
		1	On			Switching signal present
18	Rotation_steam_quantity		10	1000	200	Steam capacity for cylinder rotation
19	Rotation_Signal_delay		0	200	2	Delay of switching in alternately operation mode
20	Mode_double_cylinder		Selection			Selection Operation mode
		10	Parallel			Cylinder 1 and 2 operate with the same control signal and run in parallel
		20	Serial			One cylinder is operated at a demand of 0-50% and the other cylinder is operated at a demand of 50-100%. For a balanced load of the cylinders a cyclic rotation of the cylinders takes place.
		30	Redundant			Cylinder 1 and 2 operate in alternately mode

5.8.13 Relay extension 1 submenu



The icon is only visible in the main menu if relay extension 1 has been activated. The assignment of the respective relays and the function definition of the digital input present on the relay card can be made here.

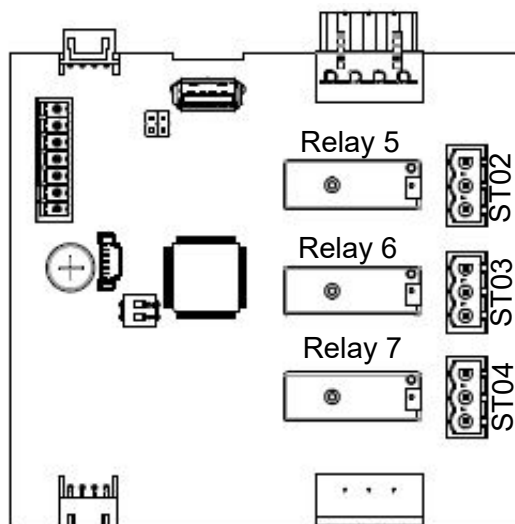

Relay designations on relay extension 1 p.c.b.

Table of control input parameters and possible relay assignments

18: Relay_extension

No.	Parameter	No.	Adjustment/value range			Meaning/Comment
			Factory setting (FS)	Min	Max	
1	Assignment_relay ST02		Selection			Assignment selection as for basic relay (see submenu Functions, no. 16)
2	Assignment_relay ST03		Selection			Assignment selection as for basic relay (see submenu Functions, no. 16)
3	Assignment_relay ST04		Selection			Assignment selection as for basic relay (see submenu Functions, no. 16)
4	Digital_input_function		Selection			Mapping of the digital input function [98] to relay board 1
13	V_Signal		see: 10-17	Function_digital_input	Read value	Voltage signal measured on terminal ST0505
14	V_Signal_%				Read value	Processed input signal corresponding to measured voltage signal on terminal ST0505 [%]
15	mA_Signal				Read value	Current signal measured on terminal ST0506
16	mA_Signal_%				Read value	Processed input signal corresponding to measured current signal on terminal ST0506 [%]
17	Ω_Signal				Read value	Resistance signal measured on terminal ST0507
18	Ω_Signal_%				Read value	Processed input signal corresponding to measured resistance signal on terminal ST0507 [%]
19	Temp.-Signal				Read value	Temperature signal measured on terminal ST0507
20	Digital_input				Read value	Actual state of the digital input [97]
		0	Off			No switching signal
		1	On			Switching signal present

5.8.14 Relay extension 2 submenu



The icon is only visible in the main menu if relay extension 2 has been activated. The assignment of the respective relays and the function definition of the digital input present on the relay card can be made here.

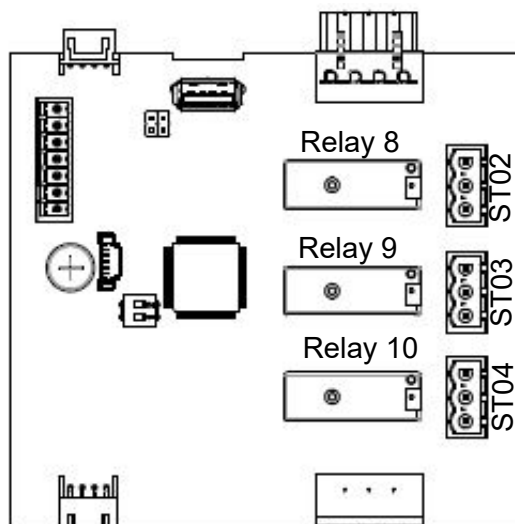

Relay designations on relay extension 2 p.c.b.

Table of control input parameters and possible relay assignments

19: Relay_extension

No.	Parameter	No.	Adjustment/value range			Meaning/Comment [] explains the term in the glossary →[] refers to a related explanation of the term
			Factory setting (FS)	Min	Max	
1	Assignment_relay ST02		Selection			Assignment selection as for basic relay (see submenu Functions, no. 16)
2	Assignment_relay ST03		Selection			Assignment selection as for basic relay (see submenu Functions, no. 16)
3	Assignment_relay ST04		Selection			Assignment selection as for basic relay (see submenu Functions, no. 16)
4	Digital_input_function		Selection			Mapping of the digital input function [98] to relay board 1
13	V_Signal		Read value			Voltage signal measured on terminal ST0505
14	V_Signal_%		Read value			Processed input signal corresponding to measured voltage signal on terminal ST0505 [%]
15	mA_Signal		Read value			Current signal measured on terminal ST0506
16	mA_Signal_%		Read value			Processed input signal corresponding to measured current signal on terminal ST0506 [%]
17	Ω_Signal		Read value			Resistance signal measured on terminal ST0507
18	Ω_Signal_%		Read value			Processed input signal corresponding to measured resistance signal on terminal ST0507 [%]
19	Temp.-Signal		Read value			Temperature signal measured on terminal ST0507
20	Digital_input		Read value			Actual state of the digital input [97]
		0	Off			No switching signal
		1	On			Switching signal present

5.8.15 TPRO submenu



The “TPRO” submenu icon is only visible in the main menu if the TPRO expansion board has been activated. Function definitions can be made here.

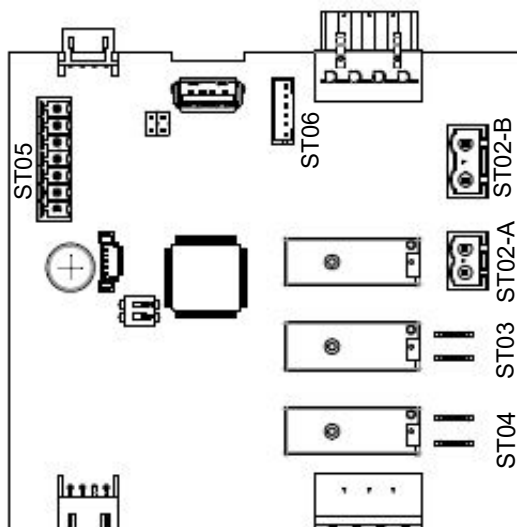

Designations on the TPRO expansion board

Table of control input parameters and possible relay assignments

20: TPRO

No.	Parameter	No.	Adjustment/value range			Meaning/Comment [] explains the term in the glossary →[] refers to a related explanation of the term
			Factory setting (FS)	Bold	FS	
1	Digital_input_function		Selection			Assignment of the digital input function [98] of the digital input [97] on the cylinder extension board
			see: 10-17 Function_digital_input			
10	V_Signal		Read value			Voltage signal measured on terminal ST0505
11	V_Signal_%		Read value			Processed input signal corresponding to measured voltage signal on terminal ST0505 [%]
12	mA_Signal		Read value			Current signal measured on terminal ST0506
13	mA_Signal_%		Read value			Processed input signal corresponding to measured current signal on terminal ST0506 [%]
14	Ω_Signal		Read value			Resistance signal measured on terminal ST0507
15	Ω_Signal_%		Read value			Processed input signal corresponding to measured resistance signal on terminal ST0507 [%]
16	Temp.-Signal		Read value			Temperature signal measured on terminal ST0507
17	Digital_input		Read value			Actual state of the digital input [97]
		0	Off			No switching signal
		1	On			Switching signal present

5.9 Screen 4 - Unit information

After an error or a status message has occurred, a display which provides information about the type of message appears in the main screen instead of the HygroMatik logo. The content of the message is described in Section 6.

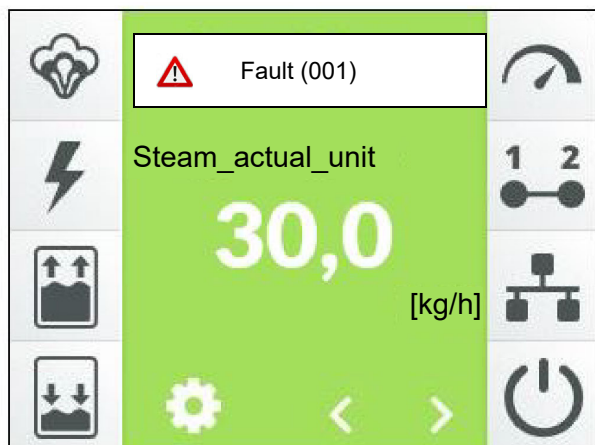

Touching this display field calls up the unit info screen which extends over several screen pages and contains comprehensive device data. As an example, one possible first screen page is shown here:

02: Information	
01: Error message_unit	Plug_ST09
02: Error_message_cyl. 1	Plug_ST09
04: Service_message_cyl. 1	No_service_message
06: Unit type	FLE20-AA10

The content of the screen pages is provided in the table in the next section.

Entries on the unit info screen

02: Information

No.	Parameter	No.	Adjustment/value range			Meaning/Comment
			Factory setting (FS) Bold			
			Min	Max	FS	
1	Fault_message_unit		Read value			List of possible unit fault messages
		0	No_fault			No fault
		1	Plug_ST09			The plug for the current transformer (ELDB) [77] or the level control (HKDB) [78] is not attached
		2	DC_Extension			There is a problem with the double cylinder board
		11	Plug_ST06			Connector ST06 on the expansion board is not plugged in.
		12	Leakage_ST0808			external leakage sensor has an error
		22	Input_current_min.			Minimum value of current input not plausible
		24	Input_resistance_OC			Minimum value of resistance input/NTC input not plausible
		25	Input_resistance_SC			Maximum value of resistance input/NTC input not plausible
		29	Internal			System fault
		30	Filling_valve 1			Fault solenoid valve 1 [19]
		45	Fill_delayed			Filling is blocked for too long via DI
		52	ST05_Input_current_min.			Minimum value of current input not plausible
		54	ST05_Input_resistance_OC			Minimum value of resistance input/NTC input not plausible
		55	ST05_Input_resistance_SC			Maximum value of resistance input/NTC input not plausible
		61	Part_blow-down			Partial blow-down [21] not successful
		62	Full_blow-down			Full blow-down [22] was not successful
		63	Blow-down_dilution			Dilution [23] was not successful (only for ELDB [77])
		64	Max._current_blow-down			Overcurrent blow-down [24] was not successful (only for ELDB [77])
		65	Max._level_blow-down			Max. level blow-down [25] was not successful (only for HKDB [78])
		66	Standby_blow-down			Stand-by blow-down [26] was not successful
		67	Start_blow-down			Start blow-down [20] not successful
		90	Cylinder_full			Sensor electrode reports cylinder full status [38] for over 60 min (only for ELDB [77])
		91	Current_measurement			Value provided by current measurement not plausible (only for ELDB [77])
		92	Main_contactor_current			A current is measured for at least 15 s, even though the main contactor [72] is not actuated (only for ELDB [77])
		93	Main_contactor_cyl._full			A cylinder full status [38] was detected for at least 15 s, even though the main contactor [72] is not actuated (only for ELDB [77])
		95	Main_contactor_current			A current is measured for at least 15 s, even though the main contactor [72] is not actuated (only for ELDB [77])
		96	Main_contactor_cyl._full			A cylinder full status [38] was detected for at least 15 s, even though the main contactor [72] is not actuated (only for ELDB [77])
		97	Current_measurement K1_2			Value provided by 2. current measurement not plausible (only for ELDB [77] TPRO)
		120	Thermoswitch			A thermo sensor [31] has been triggered (only for HKDB [78])
		121	Water_level_sensor			Value provided by level control [39] not plausible (only for HKDB [78])
		122	Max.-level			Max. level [40] was reached 5 times in a row during filling (only for HKDB [78])
		123	Steam_down_time			Despite a current feed to the radiators, the water level has not changed in the period specified →[53] (only for HKDB [78])
		124	Relay_main_contactor			The relay for the control of the main contactor is not functioning correctly
		210	Humidity_sensor			Humidity sensor, cable or input level defective
		211	Humidity_sensor 2			Humidity sensor 2, cable or input level defective
2	Fault_message_cyl. 1		Read value			List of possible fault messages for cylinder 1 (see Fault_message_unit)
		0	No_fault			No fault
		1	Plug_ST09			The plug for the current transformer (ELDB) [77] or the level control (HKDB) [78] is not attached
		29	Internal			System fault
		30	Filling_valve 1			Fault solenoid valve 1 [19]
		61	Part_blow-down			Partial blow-down [21] not successful
		62	Full_blow-down			Full blow-down [22] was not successful
		63	Blow-down_dilution			Dilution [23] was not successful (only for ELDB [77])
		64	Max._current_blow-down			Overcurrent blow-down [24] was not successful (only for ELDB [77])
		65	Max._level_blow-down			Max. level blow-down [25] was not successful (only for HKDB [78])
		66	Standby_blow-down			Stand-by blow-down [26] was not successful
		67	Start_blow-down			Start blow-down [20] not successful
		90	Cylinder_full			Sensor electrode reports cylinder full status [38] for over 60 min (only for ELDB [77])
		91	Current_measurement			Value provided by current measurement not plausible (only for ELDB [77])
		92	Main_contactor_current			A current is measured for at least 15 s, even though the main contactor [72] is not actuated (only for ELDB [77])
		93	Main_contactor_cyl._full			A cylinder full status [38] was detected for at least 15 s, even though the main contactor [72] is not actuated (only for ELDB [77])
		95	Main_contactor_current			A current is measured for at least 15 s, even though the main contactor [72] is not actuated (only for ELDB [77])
		96	Main_contactor_cyl._full			A cylinder full status [38] was detected for at least 15 s, even though the main contactor [72] is not actuated (only for ELDB [77])

Entries on the unit info screen (ctd.)

No.	Parameter	No.	Adjustment/value range			Meaning/Comment
			Factory setting (FS) Bold			
			Min	Max	FS	
		97	Current_measurement K1_2			Value provided by 2. current measurement not plausible (only for ELDB [77] TPRO)
		120	Thermoswitch			A thermo sensor [31] has been triggered (only for HKDB [78])
		121	Water_level_sensor			Value provided by level control [39] not plausible (only for HKDB [78])
		122	Max.-level			Max. level [40] was reached 5 times in a row during filling (only for HKDB [78])
		123	Steam_down_time			Despite a current feed to the radiators, the water level has not changed in the period specified →[53] (only for HKDB [78])
		124	Relay_main_contactor			The relay for the control of the main contactor is not functioning correctly
3	Fault_message_cyl. 2		Read value			List of possible fault messages for cylinder 2 (see Fault_message_unit)
			see: 02-2 Fault_message_cyl. 1			
4	Service_message_unit		Read value			Service message unit
		0	No_service_msg.			A service is not required
		1	Steam_amount_counter			A unit service is required due to the steam volume counter
		2	Cycles_main_contactor 1			The maximum number of operating cycles for K1 has been reached and a Service_main_contactor [34] is required
		12	Warning_electrodes			The condition of the electrodes will require a replacement shortly (only for ELDB [77]) →[95]
		13	Warning_pump			In the area of the blow-down pump and/or the piping, there are indications that maintenance requirements are starting to develop →[95]
		14	Warning_valve			At a solenoid valve and/or the piping, there are indications that maintenance requirements are starting to develop →[95]
		21	Fill_valve_VE			Malfunction MV demineralized water; automatic switchover to tap water MV 1
		30	Cylinder_full			Warning cylinder full untypically long lasting (only with ELDB [77])
		31	Dilution			High conductivity in the cylinder (only with ELDB [77])
		32	Clear_memory			Status message for deleting error history
		33	Factory_reset			Status message for factory reset completed.
		34	Service-reset_cyl. 1			Status message for service reset cylinder 1 completed.
		50	Cylinder			One of two cylinders is in error (only with ELDB double cylinder [77])
5	Service_message_cyl. 1		Read value			List of service messages for cylinder 1
			see: 02-4 Service_message_unit			
6	Service_message_cyl. 2		Read value			List of service messages for cylinder 2
			see: 02-4 Service_message_unit			
7	Model		Read value			Type designation of unit
8	Unit_name		Read value			Unit name [90], can be selected by the customer, if required
9	Serial_number		Read value			Serial_number
10	Date_of_manufacturing		Read value			Date_of_manufacturing
11	Software_version		Read value			Software version of control
12	Production_total_time		Read value			Total duration of steam production since initial operation (specified in days/months/years/hours/minutes)
13	Unit_total_runtime		Read value			The total runtime of the unit since its first connection to the power supply (specified in days/months/years/hours/minutes)
14	Steam_amount_total_cyl. 1		Read value			Entire steam volume of cylinder 1 [kg] produced since initial operation
15	Steam_amount_total_cyl. 2		Read value			Entire steam volume of cylinder 2 [kg] produced since initial operation (double cylinder units only)
18	Service_Reset		Selection			Reset all service messages?
		0	Off			No
		1	On			Yes

6. Faults and Warnings

6.1 Fault Management

In the event of a fault, the steam production is halted. The relevant display field is then shown instead of the HygroMatik logo. The display field shows a warning symbol, the „Fault“ message and - in paranthesis - the fault code:

e.g.:

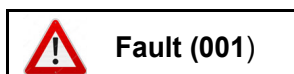



When touching the fault message display field, the unit info screen opens with the fault message in plain text and information concerning the unit and its current state.





The majority of fault messages is additionally accompanied by the flashing of one or more icons, allowing for a first limitation of the cause of fault.





6.1.1 Table of Fault Messages, possible Causes and Countermeasures

These icons flash	Fault Code	Fault message	Possible cause	Countermeasure
	001	Plug_(ST09) The plug for the current transducer or the water sensor is not connected.	<ul style="list-style-type: none"> • Plug sits not firmly or is not in place 	<ul style="list-style-type: none"> • Check plug and connect, if required
	002	Cylinder_extension Extension board not detected by the software.	<ul style="list-style-type: none"> • P.c.b. connection not o.k. • P.c.b. not present or defective • CAN bus addressing not correct 	<ul style="list-style-type: none"> • Check firm connection of boards • Connect board, replace board if defective • Check DIP switch settings on extension board (see fig. in section 3.4).
	004 005 006 007 008 009	Relay_extension 1 Relay_extension 2 HK_TPRO_Extension EL_TPRO_Extension Relay_extension 3 Relay_extension 4 Relay board (s) not detected by the software.	<ul style="list-style-type: none"> • P.c.b. connection(s) not o.k. • P.c.b.(s) not present or defective • CAN bus addressing not correct 	<ul style="list-style-type: none"> • Check firm connection of boards • Connect board(s), replace board(s) if defective • Check DIP switch settings on relay boards (see fig. in section 3.5).
	022	Input_current_min	<ul style="list-style-type: none"> • Sensor, wiring or signal source defective • Input stage defective 	<ul style="list-style-type: none"> • Check sensor, wiring and signal source, if relevant • Replace mainboard
	024 025)	Input_resistance_OC Input_resistance_SC The resistance measured is not correct („infinite“ or „zero“, resp.)	<ul style="list-style-type: none"> • Sensor, wiring or signal source defective • Input stage defective 	<ul style="list-style-type: none"> • Check sensor, wiring and signal source, if relevant • Replace mainboard





*) When the PI controller is in use, fault codes 022 to 025 relate to the sensor. In case of an external controller, the signal source is referred to.

These icons flash	Fault Code	Fault message	Possible cause	Countermeasure
	029	Internal	<ul style="list-style-type: none"> • Main board is defective 	<ul style="list-style-type: none"> • Replace mainboard
	030 032	<p>Filling_valve 1 Filling_valve 1 a. 2</p> <p>Filling was not successful, i.e. the expected filling level was not achieved after a device-specific time (15 - 45 min)</p>	<ul style="list-style-type: none"> • Solenoid valve or water supply line contaminated or defective • Solenoid valve defective • Water supply not opened • Solenoid valve electrically not driven <ul style="list-style-type: none"> - electrical cabling not o.k. - Mainboard relay not energised • Steam hose not laid with sufficient incline/decline resulting in a water bag obstructing steam flow. Steam builds up pressure in steam cylinder and pushes water towards drain • Blockage in steam pipe impedes the steam flow. The steam builds up pressure in the cylinder and presses the water into the drain. • L3 phase break-down • Main contactor does not switch L3 phase 	<ul style="list-style-type: none"> • Clean water supply line and/or solenoid valve; replace solenoid valve, if defective • Make measurement on solenoid; replace solenoid valve, if defective • Open water supply - Check electrical cable and replace, if required - Measure voltage on mainboard terminal 11 against N; replace mainboard, if required • Check steam hose layout. Eliminate water bag. • Remove blockage in steam pipe • Reestablish L3 phase feeding • Replace main contactor

These icons flash	Fault Code	Fault message	Possible cause	Countermeasure
	061 062 063 064 065 066 067	<p>Part_blow-down Full_blow-down Blow-down_dilution(only ELDB) Max._current_blow-down (only ELDB) (Max._level_blow-down (only HKDB) Standby_blow-down Start_blow-down (only HKDB)</p> <p>The respective blow-down was not successful.</p>	<ul style="list-style-type: none"> • Blow-down pump is not driven - electrical wiring is not o.k. - Mainboard relay is not energised • Blow-down pump defective • Blow-down pump is working but water is not drained (i.e. cylinder drain is blocked) • Blow-down pump blocked by scale deposits • Water sensor defective (only HKDB) 	<ul style="list-style-type: none"> - Check wiring and replace, if required - Measure voltage on mainboard terminal 10 against N; replace mainboard, if required • Replace blow-down pump • Check blow-down pump, drainage system and steam cylinder for hardeners and clean • Check blow-down pump, drain system and cylinder for scale deposits and clean • Replace water sensor
	090	<p>Cylinder_full (only ELDB) The sensor electrode consistently reports cylinder full status for 60 min</p>	<ul style="list-style-type: none"> • Low or widely fluctuating water conductivity • Electrodes worn out • No electrode cable run through current transducer • Salt bridges in steam-cylinder upper part • Foaming (when softened water is used) 	<ul style="list-style-type: none"> • Check feed water quality; consult your expert dealer, if required • Replace electrodes • Run one phase through current transducer • Clean • Increase blending rate (bigger raw water proportion)
 	091	<p>Current_measurement (only ELDB) The current transducer reading is not correct</p>	<ul style="list-style-type: none"> • Plug is not seated properly on mainboard • Current transducer defective 	<ul style="list-style-type: none"> • Check plug seating • Replace current transducer

These icons flash	Fault Code	Fault message	Possible cause	Countermeasure
	092	Main_contactor_current (only ELDB) A current is measured though the main contactor is not driven.	<ul style="list-style-type: none"> • Main contactor contact sticks 	<ul style="list-style-type: none"> • Replace main contactor
	093	Main_contactor_cyl._full (only ELDB) „Cylinder full“ is detected though the main contactor is not driven.	<ul style="list-style-type: none"> • Main contactor contact sticks 	<ul style="list-style-type: none"> • Replace main contactor
	120	Thermoswitch (only HKDB) Minimum one of the thermoswitches has tripped.	<ul style="list-style-type: none"> • Thermoswitch on steam cylinder cover has tripped due to lime coating on heating element • Capillary tube defective • Thermo switch on solid state relay has triggered due to blocked ventilation • Blockage in a connection hose (see no. 21/22 in the exploded view in the main manual) leads to incorrect water level detection, which can cause the thermal switch to trip. 	<ul style="list-style-type: none"> • Switch off power supply. Remove lime coating. Allow cool-down of steam cylinder. Push-back unblocking pin on thermoswitch with needle-nose pliers or a screwdriver • Replace thermoswitch • Switch off unit. Allow cool-down of heat sink. Remove blockage. Ensure unobstructed ventilation. Restart humidifier operation. • Replace the blocked connection hose. Switch the device on again.
 	121	Water_level_sensor (only HKDB) The water sensor reading is not plausible.	<ul style="list-style-type: none"> • Water sensor is defective • Connecting hoses blocked 	<ul style="list-style-type: none"> • Replace water sensor • Clean hoses

These icons flash	Fault Code	Fault message	Possible cause	Countermeasure
	122	<p>Max.-level (only HKDB)</p> <p>Water level has reached its maximum 5x in one single steam production phase.</p>	<ul style="list-style-type: none"> • Excessive air pressure in duct has impact on water in steam cylinder via steam hose. Water is pressed into drainage • Solenoid valve closing action imperfect. Cylinder water level rises though solenoid valve is not energised • Solenoid valve is permanently energised (water intake stops when unit is switched off) • Large amounts of residues influence or restrict cyclic blow-down. The additional water introduction caused by the optional HyFlush rinse device may cause the max. level fault 	<ul style="list-style-type: none"> • Reduce air pressure, check steam hose for blockages • Check solenoid valve • Relay contacts on mainboard stick. Measure voltage across terminal 11 and N; replace mainboard, if required • Clean steam cylinder, cylinder base, water sensor tubing and drainage system

These icons flash	Fault Code	Fault message	Possible cause	Countermeasure
 	123	Steam_down_time (only HKDB) The heaters are supplied with current, but water level doesnot change.	<ul style="list-style-type: none"> • Heater element is defective • Phase failure (external circuit breaker has tripped or is defective) • Heater elements not supplied with voltage • Main contactor swiching not o.k. • Main contactor not driven by mainboard relay 	<ul style="list-style-type: none"> • Measure heater element resistance; replace heater element, if required. Nominal resistance values are: FLH03 - 2.25 kW / 230 V - 21.3 - 26.1 Ω FLH06 – 4.5 kW / 400 V – 32.3 - 39.5 Ω FLH09 – 6.75 kW / 400 V - 21.5 - 26.3 Ω FLH15 – 3.8 kW / 400 V – 38.2 - 46.8 Ω (3x) FLH25 – 6.3 kW / 400 V – 23.1 - 28.2 Ω (3x) FLH30 – 3.8k W / 400 V - 38.2-46.8 Ω (6x) FLH40 – 6.3 kW / 400 V – 23.1 - 28.2 Ω (3x) + 3.8 kW / 400 V – 38.2 - 46.8 Ω (3x) FLH50 – 6.3 kW / 400 V – 23.1 - 28.2 Ω (6x) • Replace external circuit breaker, eliminate cause for tripping • Check wiring and voltage supply • Check main contactor; replace, if required • Measure voltage on mainboard terminal 9 against N; replace mainboard, if required
	124	Relay_main_contactor (only HKDB) The main contactor is not driven by the electronics on the mainboard, but a voltage is measured	<ul style="list-style-type: none"> • Mainboard relay contacts stick 	<ul style="list-style-type: none"> • Replace mainboard
	210 211	Humidity_sensor Humidity_sensor 2 The respective humidity sensor reading is implausible.	<ul style="list-style-type: none"> • Sensor cable defective • Sensor defective 	<ul style="list-style-type: none"> • Check sensor cable • Replace sensor

6.2 Service messages and warnings

Service messages and warnings are shown on the main screen in place of the HygroMatic logo, when the cause has occurred. When tipping the display field, the unit info screen is shown with the messages in plain text.

Mainscreen presentation	Message	Possible cause	Countermeasure
	Steam_amount counter	The maintenance interval has expired.	Service or check steam humidifier. Reset the steam amount counter (also see chapter 5.8.4.1 Monitoring and service messages“).
	Cycles_main_contactor x	The maximum number of operating cycles for the main contactor „X“ has been reached (the device can contain several main contactors. „x“ represents the designation number of the main contactor concerned).	The main contactor should be changed. After replacement, the respective counter must be reset with the parameter „Main_contactor_Kx_Reset“ (x=number of main contactor, 1...5) (also see chapter 5.8.4.1 Monitoring and service messages“).
	Warning_electrodes (only ELDB)	Electrode wear is very advanced.	Replace Electrodes.
	Warning_pump	A performance capability decrease is detected in the area of the blow-down pump and its hosing.	Check area and clean. If warning persists, replace blow-down pump.
	Warning_valve	A performance capability decrease is detected in the area of the solenoid valve, cylinder base and its hosing.	Check area and clean. If warning persists check cylinder base for lime deposit.

The sensitivity threshold of the last three warning messages is set to the highest level ex-factory. Should the on-site conditions (e.g. the water conductivity) lead to an unwanted frequent occurrence of the messages, the sensitivity can be reduced in the „Service“ submenu (s. section 5.8.4).

6.3 Table of functional disruptions

Problem	Possible cause for faulty situation	Countermeasure
Set humidity level not reached	<ul style="list-style-type: none"> • Output limitation parameter setting impedes full power output • Nominal unit output insufficient • Phase failure • Lengthy steam hose layout crossing cold and drafty rooms may lead to increased condensate formation • Improper steam manifold installation may cause condensate formation within air duct • Control signal not properly selected or software setting mismatch • Water quality requires water concentration for full steam output • Excessive pressure in duct system caused by e.g. water bags or partly blocked steam pipes (max. overpressure is 1200 Pa) 	<ul style="list-style-type: none"> • Check „Steam_output_max.“ parameter setting („Control“ submenu, line 2) • Check unit technical data, airflow and secondary airflow • Check circuit breakers • Change unit installation location allowing for shorter steam hose. Insulate steam hose • Check steam manifold position within total system and installation correctness • Check control signal and „Control_settings“ parameter („Control“ submenu, line 1) • Wait • Eliminate particular cause(s)
Excessive humidity	<ul style="list-style-type: none"> • A steam output limitation setting that is too high may result in poor control performance and even condensate formation in ducts • Control signal not properly selected or software setting mismatch 	<ul style="list-style-type: none"> • Check „Steam_output_max.“ parameter setting („Control“ submenu, line 2) • Check control signal and „Control_settings“ parameter („Control“ submenu, line 1)

Problem	Possible cause for faulty situation	Countermeasure
Water collects on bottom plate	<ul style="list-style-type: none"> • Cylinder improperly reassembled following maintenance: <ul style="list-style-type: none"> - O-ring not replaced, defective or not in place - Flange (tongue and groove) damaged - Flange improperly composed - Mineral deposits in flange area • Cylinder improperly inserted in cylinder base • Water cannot drain freely when pumped from cylinder 	<ul style="list-style-type: none"> • Clean cylinder and assemble / install properly • Using moistened new O-ring, insert steam cylinder properly into cylinder base • Make sure drain is unobstructed
Water leaks from steam cylinder upper part	<ul style="list-style-type: none"> • Hose clamps on steam and/or condensate hose not tightened • Steam hose adapter not properly fit or O-ring not replaced 	<ul style="list-style-type: none"> • Tighten clamps • Replace O-ring (if required) and ensure proper adapter installation
No steam production despite the steam humidifier being switched on. Display not illuminated	<ul style="list-style-type: none"> • Defective F1 and/or F2 fuses on main-board • External control voltage failure (ext. circuit breaker has tripped or is defective) • device load circuit breaker has tripped (only ELDB) 	<ul style="list-style-type: none"> • Check micro fuses and replace, if required • Replace breaker and investigate possible causes • Switch on breaker. If problem persists, check for reason
No steam production despite the steam generator being switched on and an illuminated display	<ul style="list-style-type: none"> • The interlock (safety) system is open • The humidity set value has been reached. The control receives no demand for steam production. • A fault has occurred 	<ul style="list-style-type: none"> • Close interlock (safety) system • Check humidity set value and plausibility of actual humidity value • Check unit status
No steam production. Voltage across electrodes exist, but no water is fed into the cylinder (only ELDB)	<ul style="list-style-type: none"> • Water supply not opened or solenoid valve electrically not driven 	<ul style="list-style-type: none"> • Open water supply (s. also Filling fault messages 030 and 032)

Problem	Possible cause for faulty situation	Countermeasure
Blow-down pump works but no water is drained	<ul style="list-style-type: none"> • Steam cylinder and/or drainage system blocked 	<ul style="list-style-type: none"> • Clean cylinder base and/or drainage system, respectively
Cylinder is fully drained after partial blow-down despite pump being switched off	<ul style="list-style-type: none"> • Vent pipe is blocked 	<ul style="list-style-type: none"> • Clean venting bore; replace vent pipe, if required
No steam exit from steam manifold	<ul style="list-style-type: none"> • Steam pipe improperly laid (water bag) or blockage 	<ul style="list-style-type: none"> • Rerun steam hose according to guide lines • Remove blockage
Water exits periodically from drain hose without pump switched on	<ul style="list-style-type: none"> • Excess pressure in duct system (max. overpressure is 1200 Pa) 	<ul style="list-style-type: none"> • Lengthen drain hose system; consult your expert dealer if problem persists
Uneven electrode wear (ELDB only)	<ul style="list-style-type: none"> • One or more electrodes not supplied with power • Circuit breaker tripped • Main contactor contact not functional • Phase loading not symmetric • Electrode immersion depth differs. Unit not mounted plumb 	<ul style="list-style-type: none"> • Check power supply and electrode wiring • Check circuit breaker. Replace, if required • Check main contactor. Replace, if required • Ensure power supply phase balance by measurement • Check installation and correct positioning, if required

Problem	Possible cause for faulty situation	Countermeasure
Flashover/sparks in cylinder(only ELDB)	<ul style="list-style-type: none"> • Very high water conductivity resulting in massive electrode burn-off as indicated by brown-black deposits • Blow-down pump not working properly or defective 	<ul style="list-style-type: none"> • Deactivate unit immediately to prevent material damage Perform maintenance: <ul style="list-style-type: none"> - replace electrodes with high conductivity type - clean steam cylinder - check water quality and conductivity (also s. „Intended use“ section) - optimise blow-down parameters Consult your expert dealer, if required • Check blow-down pump functioning and replace pump, if required. See also fault messages 061 to 067 related to blow-down

7. Wiring diagrams

The device-specific wiring diagrams are included in the scope of delivery. Please use them for the installation and keep them in a safe place.

8. Glossary

Term	[Index]	Explanation
Actual value	1	The actual value is the measured value of a physical quantity, which is compared with the → <i>Set value</i> [3] during the control process and may give rise to a readjustment, if required.
Relative humidity (r.h.)	2	The relative humidity (r.h.) describes the maximum percentage of moisture which the ambient air can hold at a certain temperature.
Set value	3	The set value of a physical quantity (e.g. the → <i>r. h.</i> [2]) is the set target for a control process.
Steam output	4	The steam output calculated from the electrical power consumption in kg/h.
Demand	5	The demand describes the dimensionless control signal processed by the control system which is converted into a proportional → <i>Internal actuator signal</i> [42] for the power control for steam generation.
Hygrostat	6	Sensor with switching function for the → <i>Relative humidity (r.h.)</i> [2] in rooms. The trigger point for the switching function with potential free contacts can be set mechanically. The hygrostat can be used to control → <i>1 step operation</i> [44] or in the → <i>Interlock (safety) system</i> [11] to protect against excess humidity.
Update function	7	The update function provides the control with an update of parameter settings which is stored on an external USB memory stick. The "Update function" parameter is a read-only value which can be used to read out the status of the update.
SI system of units	8	The system of units with the temperature specified in °C and the quantity specified in kg.
Imperial system of units	9	The system of units used in the USA with the temperature specified in °F (Fahrenheit) and the quantity specified in lbs.
Initialisation	10	The control performs a self-test, during which the welcome screen with the software version is displayed. After the parameter settings and measured values have been read in, the → <i>Main screen</i> [14] is shown on the display. During the subsequent start blow-down, the read values can be used to query the device status, which is "Initialisation" in this phase.
Interlock (safety) system	11	The hardware interlock (safety) system makes it possible to immediately interrupt steam production, e.g. using an emergency stop button. The interlock (safety) system must be closed to operate the unit. The interlock (safety) system must be implemented on-site with one or several potential free contacts (switched in series). It is connected to the control at terminals 1 and 2, with terminal 1 carrying 230 VAC as standard. In a special design (e.g. for the U.S. market), the interlock (safety) system is converted to low voltage through the additional use of a relay to meet local safety requirements. Instead of terminals 1 and 2 on the control, a potential free connection of the relevant DIN rail terminals must then be implemented on-site. If the interlock (safety) system is opened, the status of the unit changes to "Interlock (safety) system open".
Software control command	12	Coded command, which is, for example, sent from the building control system or a PLC via the → <i>Communication interface</i> [13] to the control. The command set available is listed in separate documentation, which is available from HygroMatik on request.
Communication interface	13	Serial computer interface for remote control of the unit using, for example, the → <i>Modbus</i> [17] RTU protocol.
Main screen	14	Screen content during the normal operation of the unit. The main screen includes the main display (in the middle of the screen) and the status icons (left and right of the main display).
Standby heating	16	So that steam production can be started more quickly, the standby heating keeps the water in the cylinder warm, if no → <i>Demand</i> [5] is present. The → <i>Interlock (safety) system</i> [11] must be closed. Heating and pause times are adjustable.
Modbus	17	Modbus is a communications protocol for serial data transmission for the remote control of units, which is widely used in industry. HygroMatik controls use the MODBUS - RTU (remote terminal unit) variant. Separate documentation is available upon request from HygroMatik.
Timer function	18	The timer makes it possible to limit the duration of steam production in the short-time range, starting when steam production is halted (if no demand exists in normal operation), or ECO mode . The timer is triggered by pressing a button, which must be connected to the <i>digital input</i> [97] of the mainboard. In addition, the → <i>Digital function</i> [98] parameter must be set to "Timer_start". The "0" setting deactivates the timer. "1" or "2" is used to specify whether the steam is turned off or if there is a return to ECO mode after the timer has elapsed.
Solenoid valve (SV)	19	The solenoid valves for the water supply to the steam cylinder(s) are labelled with Y1, Y2, Y3 and Y4 in the circuit diagrams.
Start blow-down	20	The unit performs a → <i>Blow-down</i> [58] after it was switched off and has been switched on again. The process varies depending on the unit type. For the → <i>ELDB</i> [77] it is important that, when the main contactor is first switched, overcurrent due to excessive conductivity of the cylinder water does not occur while simultaneously water level is high. A → <i>Partial blow-down</i> [21] is therefore used to ensure that the current does not reach an impermissible value. This procedure is not required for the → <i>HKDB</i> [78]. The only checks carried out here are on the functioning of the level control and the blow-down pump, by carrying out a plausibility check of the measured value of the water level sensor which is transferred in the context of a → <i>partial blow-down</i> [21].
Partial blow-down	21	Only part of the cylinder water is pumped off during the → <i>Blow-down</i> [58]. For the → <i>ELDB</i> [77], a partial blow-down is carried out periodically after 40 solenoid valve operating cycles (fillings), when the standard setting is left untouched. For the → <i>HKDB</i> [78], the frequency of the partial blow-down is determined by the steam volume.
Full blow-down	22	All of the cylinder water is pumped off during the → <i>Blow-down</i> [58].
Dilution	23	A dilution is a → <i>Partial blow-down</i> [21], which is caused by excessive conductivity of the cylinder water. For deconcentration, fresh water is used to top up the cylinder after the partial blow-down.

Glossary ctd. (1)

Term	[Index]	Explanation
Overcurrent blow-down	24	Depending on the selection of the → <i>Control curve</i> , the current is increased to 128% or 113% of the nominal current during a cold start, in order to achieve a quick start characteristic. When the respective current value has been reached, the overcurrent blow-down is started causing the nominal current to revert to the normal value (only for → <i>ELDB [77]</i>).
Max. level blow-down	25	When the water level sensor signals the maximum level, a → <i>Partial blow-down [21]</i> is carried out to reduce the water level (only for → <i>HKDB [78]</i>).
Stand-by blow-down	26	If the unit was switched on for an extended period without a → <i>Demand [5]</i> arising, or if the → <i>Interlock (safety) system [11]</i> was opened for an extended period, a (→ <i>Blow-down [58]</i>) of the cylinder water is performed to prevent germ formation. The interval for triggering the blow-down is defined with the "Standby blow-down interval" parameter.
Flushing of dead-end line	27	When this function is activated, the feed water line is flushed during operation phases in which there are no requests in order to prevent germ formation. For this purpose, the inlet solenoid valve and the blow-down pump are activated at the same time. The "Flushing_of_dead-end_line_interval" parameter determines when flushing starts after a request was not received, the "Flushing_of_dead-end_line_duration" parameter determines how long flushing takes. The interlock (safety) system must be closed so that the inlet solenoid valve can be controlled ("partially automatic flushing of dead-end line").
Manual blow-down	28	Pumping out of the cylinder water by touching the "Blow-down" icon on the screen or by a → <i>Software control command [12]</i> via the → <i>Communication interface [13]</i> . Repeated actuation or a corresponding → <i>Software command [12]</i> switches the → <i>Blow-down function [58]</i> off again. The cylinder water may also be pumped by setting the control switch on the device front panel in the "II" position while the control remains switched off.
Thermo sensor	31	With the → <i>HKDB [78]</i> , a thermo sensor is located on the cylinder cover, connected to the heater(s) via a capillary tube. A thermal switch is also arranged on every → <i>Solid state relay [46]</i> . All thermo sensors/thermal switches are connected in series. If one of the thermo sensors/thermal switches is triggered, the power supply to the steam humidifier is interrupted. The thermo sensor(s) on the cylinder(s) have to be reset mechanically after cooling down. The thermal switches are automatically reset after cooling down.
Limitation of operating time	32	The unit stops the steam production according to the number of minutes specified. The time is counted from the point when the interlock (safety) system was closed. To put the unit back into operation, the interlock (safety) system must be opened and closed again, or the → <i>Communication interface [13]</i> must be used to transmit → <i>Software control commands [12]</i> to open and close the virtual interlock (safety) system again. Alternatively, the control switch can also be opened and closed again. This does, however, cause the unit to be restarted. Setting the parameter to a value of "0" deactivates the limitation of operating time.
Steam_amount_service	33	The steam volume produced [kg] is compared to the default value set in the "Steam_amount_service" parameter to obtain a criterion for maintenance requirements. Once the default value has been reached, the message "Steam_amount_counter" is displayed. Once the service has been performed, the steam volume counter has to be reset with "Service_reset_cyl. x". The remaining steam volume can be viewed using the "Steam_until_msg_cyl. x" read value.
Service_main_contactor	34	The operating cycles of the main contactor(s) are recorded by counters and compared to factory-set default values by the software. When a default value is reached, the "Service_main_contactor x" message is displayed on the screen. After a main contactor has been replaced, the respective counter must be reset with the parameter "Main_contactor_x_Reset" (x = number of the main contactor, 1...5).
Floating max. limiter	35	<p>The floating max. limiter serves for protection against excessive humidification of the channel. In case of the room sensor sending a demand while the channel has already reached its maximum humidity capacity, a floating max. limiter allows for a much more sensitive limitation of the steam supply when compared to a max. hygrostat. While the max- hygrostat switches off only when the maximum humidity is reached, the floating max. limiter tracks the humidity progress and turns down the steam production based on a settable control curve until a defined max. humidity is reached. This aims to ensure that no excessive humidification may occur in the channel.</p> <p>To use this function, a 2nd humidity sensor must be mounted in the channel (typical mouting position is the range where the steam is introduced into the channel by the humidifier).</p> <p>Connecting the 2nd humidity sensor</p> <p>If the unit only features a mainboard, the 1st humidity sensor must be of the "Humidity sensor with 0...10 V output voltage" type to allow for the implementation of the floating max. limiter function. The secon humidity sensor is than wired to the current input of the mainboard. To allow for this, the sensor must feature a 4...20 mA current output signal. In case of an additional board built into the unit, however, the 2nd humidity sensor is to be wired to this board making use of the 0...10 V voltage input, just as is the case with the mainboard. Consequently, the humidity sensor must be of the 0...10 V voltage type.</p> <p>Activating the floating max. limiter</p> <p>Activating is accomplished by setting the "Control settings" parameter in submenu "Control" to "11" or "12". The setting must be in accordance with the wiring chosen for the 2nd humidity sensor. If no 2nd humidity sensor is connected, the parameter setting is not saved.</p> <p>Example: The 2nd humidity sensor was connected to the current input of the mainboard. For the "Control settings" parameter, the "11" is to be chosen as the setting value.</p> <p>Parameter settings for the floating max. limiter</p> <p>For the floating turning-down of the humidity set value, the control curve steepness may be set with the "PI-controller_max_gain" parameter. Factory pre-setting (FP) is "5". The humidity set value for the shut-down point is defined by the "Humidity_set_max" parameter (FP = 80%).</p>

Glossary ctd. (2)

Term	[Index]	Explanation
Cylinder full status	38	When the unit measures a voltage at the sensor electrode, it reports a cylinder full status. In this case, the cylinder water level is so high that it creates an electrical bridge between one of the power electrodes and the sensor electrode. If the cylinder full status continues for an hour, steam production is shut down and a fault message is generated.
Level control	39	With the →HKDB [78], communicating tubes are used for the contact-free measurement of the water level in the cylinder.
Max. level	40	The maximum water level value supplied by the →Level control is reached. If this state is reached 5x in succession within a predefined time interval, the control issues a "Error_max.level" message (only →HKDB [78]).
Internal actuator signal	42	Actuator signal for the control of the power element of the unit concerned.
Max. steam output	43	Reduction of output power to 25... 100% of the nominal output. Can lead to improved control behaviour at lower output requirements.
1 step operation	44	On/off operation of the steam humidifier without control function through a potential free contact suitable for low voltage, to be supplied on-site. The control can, for example, be implemented using a →Hygrostat [6], which has to be connected to a potential free make contact between terminals 3 and 5 of the control.
Solid state relay (SSR)	46	Electronical power switch mounted on a thermally monitored heat sink (only →HKDB [78]).
Humidification	47	The unit produces steam, if a →Hygrostat [6], an →External control [73], a Humidity sensor or a →Software control command [12] has issued a →Demand [5] and the →Interlock (safety) system [11] is closed.
PWM	48	Pulse width modulation with variable frequency and variable duty cycle for the control of the heater current via the →Solid state relay [46]. Because the heater current determines the steam output, it is possible to control the steam output in this way (only for →HKDB [78]).
Correction_x_signal	49	Used for the calibration of a humidity sensor output signal as the →Input signal [72] of the control (x = "V", "mA", "Ω").
Δ Dehumidifying	50	Specifies the percentage by which the →Set value [3] of the →r.h. [2] has to be exceeded until the "Dehumidify" signal becomes available at the selected relay, if this relay is set to "210".
Δ Humidity_ECO	51	To conserve energy, the →set value [3] of the →r.h. [2] can be lowered by the value stored in "Δ Humidity_ECO". For this purpose, a →pushbutton [106] has to be wired to the →Digital input and the function of the digital input has to be programmed to "ECO". This function is available only in connection with the "PI controller" control type.
Steam_down_time_to_fault	53	If the level of the cylinder water has not changed within the time defined in this parameter, this indicates that a malfunction is present. The steam production is then suspended and the "Steam_down_time" fault message is output (only →HKDB [78]).
Filling_cycled	54	The fill operation does not take place continuously, but with breaks, in order to prevent the overflowing of the filling cup (HyFlow). Filling and pause intervals can be adjusted separately.
Blow-down correction	55	If the water has high electrical conductivity or if there is a very high level of maintenance, it may be useful to increase the blow-down frequency. At low electrical conductivity, however, a reduction in the frequency of the blow-down may be useful. Depending on the water quality, the blow-down rate can be adjusted in 10 steps ("0" is the default). More frequent blow-down: Values up to max. +5, less frequent blow-down values down to -5, whereby "-5" means that blow-down is completely switched off.
Pumps_without_main_contactor	56	In rare cases, leakage currents may flow through the water to the earth during the blow-down process. To prevent a sensitive fault current circuit breaker from tripping, the main contactor can be switched off during the pumping process (only →ELDB [77]).
HyFlush (option)	57	When open, an additional solenoid valve produces a rotating turbulence for an improved discharge of scale deposits during blow-down. The solenoid valve is controlled by the software with a fixed ratio of active and pause times.
Blow-down	58	Pumping off the water in the cylinder for the following reasons: Elimination of scale deposits, replacement of water to prevent germ formation and reduction of conductivity (only →ELDB [77]), which increases due to evaporation and leads to increased power consumption. A distinction is made between →Full blow-down [22] and →Partial blow-down [21].
HyCool (option)	59	Waste water cooling system for the protection of temperature-sensitive plastic waste water pipes. A solenoid valve is used to mix fresh water with the waste water so that the water temperature does not exceed 60 °C.
ECO mode	61	Lowering of →Humidity set value [3] to conserve energy.
Power level	63	If the →HKDB [78] is equipped with more than 3 heaters, the power is provided in 2 levels from a certain performance class onwards. As long as a certain threshold value has not been reached, the heating performance required is exclusively controlled via the →Solid state relay [46] and 3 heater elements by means of proportional control (stage 1). If the output power demand exceeds the power available in stage 1, 3 more heater elements are additionally switched on in a 1-step mode (stage 2). The power demand beyond what is available in stage 2 is then covered in stage 1 by the solid state relay driven in proportional mode.
Relay assignment	65	If the basic relay or additional relays which may be present are not used for signalling but for direct load switching, the maximum contact load 250 VAC/8 A must be taken into account
Control curves	68	In the "Load optimised" factory setting, the power control of an →ELDB [77] is set so that a current of 113% of the nominal current is permitted during a cold start to avoid overloading the power supply. In the "Energy optimised" setting, the current is increased to 128% of the nominal current during a cold start for achievement of a preferably short heat-up period. In the "Process optimised" setting, control is particularly fine.

Glossary ctd. (3)

Term	[Index]	Explanation
Output signal	69	Signal 0... 10 V on terminals 12 and 13 (GND), which is proportional to the input signal. Can be used to control downstream units.
Input signal	72	The electrical signal fed to the control at the ST08 plug of the mainboard or the ST05 plug of the relay board. Depending on the signal characteristic (Voltage, current or resistivity progress), a certain pin of the corresponding plug is used. The signal range of the input signal (e.g. 0...10V) is to be adapted by setting of the related parameter. Using the <i>Correction_x_signal</i> [49] parameters, the output signal of a humidity sensor may be calibrated.
External controller	73	The control uses the output signal of an external controller to control the power element for steam generation. The input level of the control can be adapted to different signal types and value ranges. Other possible input signals are the output signal of a humidity sensor (in connection with the internal PI controller), the switching contact of a <i>Hygrostat</i> [6] (for <i>→ 1 step operation</i> [44]) and a <i>→ Software command</i> [12] via the <i>→ Communication interface</i> [13].
Dropout delay	74	By assigning the "8" value to one of the relay contacts, a control signal for the delayed closing of a steam valve is made available for pressure reduction. The dropout delay is set with the "Humidification_off_delay" parameter. Factory default is 60 s.
Main contactor	75	The installed main contactors are labelled K1...K4. The operating cycles of the main contactor(s) are monitored and compared with the value specified by the manufacturer for the expected service life. When the stored value is reached, the message "Service_main_contactor" is generated. After the main contactor has been replaced, the status message must be deleted, for example using the <i>→Main_contactor_K1_Reset = "1"</i> parameter.
ELDB	77	Electrode steam humidifier.
HKDB	78	Heater steam humidifier.
HVAC	79	Heating, Ventilation, Air Condition: Generic term in the English language area for air conditioning equipment.
Virtual interlock (safety) system	86	If control via <i>→ Communication interface</i> [13] was selected, software is used to place a logical switch in series with the hardware interlock (safety) system. This switch can be opened and closed via <i>→ Software commands</i> [12]. If the hardware interlock (safety) system is closed and the switch is opened via software control command, steam production is stopped and the unit is placed in "Remote switch-off" status.
Supply voltage	89	The units are designed for connection to supply voltage ranges (e.g. 380 to 415 VAC in case of a 400 VAC unit, s. name plate)
Unit name	90	Here, "Plant 1" is entered by default.
Weekly timer	91	The timer makes it possible to program 2 periods per day of the week, each defined by a start time and a end time. The humidity set-value can be preset for each time period.
Recording	93	The control can record 10 data sets internally on a rolling basis. Snapshots of the unit status are carried out at intervals of 10 s, which can be helpful for troubleshooting. When the storage space is filled, a new set of data overrides the oldest entry. The complete record can be saved to a USB stick with NTFS formatting.
Slave	94	The unit functions as a slave in a master/slave arrangement, where a control unit (master) can control up to 3 slaves for the purpose of improving the output performance of the entire system. The slaves are switched sequentially. The output signal of the master on terminals 12, 13 is connected to the input terminals of the 1. slave. The input signal assignment of the 1st slave (and all subsequent ones) must be set to "Slave", this also applies to the output signal assignment for the master and all slaves.
Warning message	95	The electrodes (for the <i>→ ELDB</i> [77]), the blow-down pump and the solenoid valves are items with limited service life due to wear and tear. They must be checked during maintenance works and replaced if required. To avoid unplanned maintenance requirements, alerts can be set up for the respective items, which are activated when a defined state of wear is reached. The criteria for the alerts to be triggered can be defined in three stages each through the sensitivity setting.
PI controller	96	Internal controller with control characteristics which contain a Proportional part and an Intergal part. Both parts can be changed as parameters.
Digital input	97	Digital input on the mainboard and on the relay boards for switching functions. A logical meaning (e.g. timer start) is assigned to the digital input via the <i>→ Digital_input_function</i> [98] parameter. The digital input must be wired on-site in accordance with its use, e.g. with a <i>→ Pushbutton</i> [106] or a <i>→ Switch (NO)</i> [102] against the 20 VDC on terminal 8 on the mainboard terminal strip ST08 or the terminal strip ST05 on the other available boards. When the 20 VDC voltage is applied (short-term via a <i>→ Pushbutton</i> [106] or permanent via a <i>→ Switch (NO)</i> [102]), as required in accordance with <i>→ Digital_input_function</i> [98] parameter setting), the switching function is carried out.
Digital_input_function	98	Determines which function will be executed if the <i>→ Digital input</i> [97] on the mainboard or one of the relay boards is loaded externally with level "1" (= 12 V).
Nominal power output	99	The steam output range given on the name plate derived from the allowable range of supply voltages

Glossary ctd. (4)

Term	[Index]	Explanation
Power section	100	That part of the unit that makes the energy conversion from the current supplied into steam output
Load shedding	101	Load shedding can be set up by assigning the →Function_digital_input [98] "Power limitation" to the →Digital input [97]. When the →Digital input [97] is then then connected to an →Auxiliary voltage [105] by means of a →Switch (NO) [102], →Max. steam output [43] is reduced by the percentage set up in the "Δ power limitation" parameter. After withdrawal of the voltage normal operation is reestablished.
Switch (NO)	102	Electrical switch with N ormally O pen contacts
Steam_down_time_min.	103	Steam-down time between fillings is continuously monitored. If the minimum steam-down time set falls below the value set up several times in a row, an indication exits that the cylinder water conductivity has risen to an extend non tolerable. For conductivity reduction, →Dilution [23] is triggered (only →ELDB [77]).
Slave_hysteresis	104	In order to avoid unnecessary frequent switching on and off of →Slave [94] units (as required by the output demand) or an oscillating tendency, switching is made with a hysteresis. Example: One Master controls one Slave. Switching on the slave without hysteresis would occur at 50% output demand, same situation for switching the slave off. With a 1% hysteresis, switching on the slave is at 51% output demand whereas switching off is at 49%. By this, instability of the switch-off point is accomplished.
Auxiliary voltage	105	DC voltage in the range of 5...20V for activating the →Digital input [97] via a →Pushbutton switch [106] or a →Switch [102]. +20 VDC is available on Pin 3 of ST08 (mainboard) or ST05 (relay board). The auxiliary voltage is required to switch the →Digital_input [97] on the mainboard or a relay board in order to trigger the function defined by setting the →Function_digital_input [98] (e.g. switch on ECO mode).
Push button	106	Electrical switch for momentary action
Fully automatic deadleg flushing	107	For "fully automatic" →Deadleg flushing [27], an additional relay must be implemented that allows for switching the intake solenoid valve even when the →Interlock (safety) system [11] is open. Control of this additional relay is either by the base relay on the mainboard or a coupling relay. The relay used for this function must have "68" as the assignment.

9. Technical Data

FLE-T

Technical specifications FlexLine electrodes						
Unit type	FLE05-T	FLE10-T	FLE15-T	FLE20-T	FLE25-T	FLE30-T
Steam output [kg/h]	4,7 - 5,0 - 5,2	9,5 - 10,0 - 10,4	14,2 - 15,0 - 15,5	19,0 - 20,0 - 20,8	23,8 - 25,0 - 26,0	28,5 - 30,0 - 31,1
Electrical connection ⁽¹⁾	380 - 400 - 415V /3Ph /N /50-60Hz					
Rated power [kW]	3,6 - 3,7 - 3,9	7,1 - 7,5 - 7,8	10,7 - 11,2 - 11,6	14,3 - 15 - 15,6	17,8 - 18,8 - 19,5	21,4 - 22,5 - 23,4
Nominal current [A]	5,4 - 5,4 - 5,4	10,8 - 10,8 - 10,8	16,2 - 16,2 - 16,2	21,7 - 21,7 - 21,7	27,1 - 27,1 - 27,1	32,5 - 32,5 - 32,5
Fuse [A] ⁽²⁾	3 x 10	3 x 16	3 x 20	3 x 32		3 x 40
Terminals max. [mm ²]	4			10		
Number of steam cylinder	1					
Control	FlexLine mainboard with capacitive 3.5" touch colour display					
Separate control voltage ⁽³⁾	220 - 240V 2,5A					
Steam hose connection [mm]	1 x 25			1 x 40		
Water consumption ⁽⁷⁾ [l/h]	6,2	12,5	18,6	25,0	31,2	37,3
Water flow rate ⁽⁸⁾ [l/min]	1,3 / 20,5		2,8 / 22,0		4,1 / 23,3	
Max. filling capacity [l]	4,8		13,2		20,9	
Empty weight [kg]	16,0		22,0		23,0	
Operation weight [kg]	21,3		35,7		36,7	
Width ⁽⁹⁾ [mm]	460 ⁽¹¹⁾		540		580	
Height ⁽⁹⁾ [mm]	535		695		750	
Depth ⁽⁹⁾ [mm]			320		355	
Water connection	tap water of varying qualities 1 to 10bar, 1 to 10 bar, for 3/4" external thread					
Drain water connection	Connection Ø 1 1/4"					

Technical specifications FlexLine electrodes							
Unit type	FLE40-T	FLE50-T	FLE65-T	FLE80-T	FLE100-T	FLE130-T	
Steam output [kg/h]	38,0 - 40,0 - 41,5	47,5 - 50,0 - 51,8	61,8 - 65,0 - 67,5	76,0 - 80,0 - 83,0	95,0 - 100,0 - 104,0	124,0 - 130,0 - 135,0	
Electrical connection ⁽¹⁾	380 - 400 - 415V /3Ph /N /50-60Hz						
Rated power [kW]	28,5 - 30 - 31,1	35,6 - 37,5 - 38,9	46,3 - 48,8 - 50,6	2 X 28,5 - 30 - 31,1	2 X 35,6 - 37,5 - 38,9	2 X 46,3 - 48,8 - 50,6	
Nominal current [A]	43,3 - 43,3 - 43,3	54,1 - 54,1 - 54,1	70,4 - 70,4 - 70,4	2 X 43,3 - 43,3 - 43,3	2 X 54,1 - 54,1 - 54,1	2 X 70,4 - 70,4 - 70,4	
Fuse [A] ⁽²⁾	3 x 50	3 x 63	3 x 80	2 x 3 x 50	2 x 3 x 63	2 x 3 x 80	
Terminals max. [mm ²]	16	25		16	25		
Number of steam cylinder	1			2			
Control	FlexLine mainboard with capacitive 3.5" touch colour display						
Separate control voltage ⁽³⁾	220 - 240V 2,5A						
Steam hose connection [mm]	2 x 40 ⁽⁶⁾	2 x 40		4 x 40 ⁽⁶⁾	4 x 40		
Water consumption ⁽⁷⁾ [l/h]	49,8	62,2	81	99,6	124,8	162,0	
Water flow rate ⁽⁸⁾ [l/min]	4,1 / 23,3		2 x 4,1 / 23,3				
Max. filling capacity [l]	20,9	35,7		41,8	71,4		
Empty weight [kg]	25,0	33,0	34,0	66,0	75,0		
Operation weight [kg]	46,4	69,2	70,2	108,3	146,9		
Width ⁽⁹⁾ [mm]	580	640		1130	1170		
Height ⁽⁹⁾ [mm]	750	785		750	785		
Depth ⁽⁹⁾ [mm]	355	420					
Water connection	tap water of varying qualities 1 to 10bar, 1 to 10 bar, for 3/4" external thread						
Drain water connection	Connection Ø 1 1/4"			2x Connection Ø 1 1/4"			

⁽¹⁾ Other voltages upon request.

⁽³⁾ Internal control voltage upon request.

⁽⁶⁾ Incl. Y-piece DN40

⁽²⁾ 13/28% above nominal power consumption after full blowdown. Observe actuation characteristics of automatic circuit-breakers.
If necessary, select the next highest circuit-breaker level.

⁽⁷⁾ Maximum water consumption at 100% demand plus blowdown losses. The water consumption depends on the water quality and installed options.

⁽⁸⁾ Flow rate of the feed water during refilling or pumping out. Unit without options / maximum rate with options.

⁽⁹⁾ Outer dimensions of width and depth. High incl.drain connection.

⁽¹¹⁾ Units with production date January 2022 and earlier: 540 mm

FLE-TPRO

Technical specifications FlexLine electrodes						
Unit type	FLE05-TPRO	FLE10-TPRO	FLE15-TPRO	FLE20-TPRO	FLE25-TPRO	FLE30-TPRO
Steam output [kg/h]	4,7 - 5,0 - 5,2	9,5 - 10,0 - 10,4	14,2 - 15,0 - 15,5	19,0 - 20,0 - 20,8	23,8 - 25,0 - 26,0	28,5 - 30,0 - 31,1
Electrical connection ⁽¹⁾	380 - 400 - 415V /3Ph /N /50-60Hz					
Rated power [kW]	3,6 - 3,7 - 3,9	7,1 - 7,5 - 7,8	10,7 - 11,2 - 11,6	14,3 - 15 - 15,6	17,8 - 18,8 - 19,5	21,4 - 22,5 - 23,4
Nominal current [A]	5,4 - 5,4 - 5,4	10,8 - 10,8 - 10,8	16,2 - 16,2 - 16,2	21,7 - 21,7 - 21,7	27,1 - 27,1 - 27,1	32,5 - 32,5 - 32,5
Fuse [A] ⁽²⁾	3 x 10	3 x 16	3 x 20	3 x 32		3 x 40
Terminals max. [mm ²]	4			10		
Number of steam cylinder	1					
Control	FlexLine TPRO mainboard with capacitive 3.5" touch colour display					
Separate control voltage ⁽³⁾	220 - 240V 2,5A					
Steam hose connection [mm]	1 x 25			1 x 40		
Water consumption ⁽⁷⁾ [l/h]	6,2	12,5	18,6	25,0	31,2	37,3
Water flow rate ⁽⁸⁾ [l/min]	1,3 / 20,5		2,8 / 22,0		4,1 / 23,3	
Max. filling capacity [l]	4,8		13,2		20,9	
Empty weight [kg]	16,0		22,0		23,0	26,0
Operation weight [kg]	21,3		35,7		36,7	47,4
Width ⁽⁹⁾ [mm]	460 ⁽¹¹⁾		540		580	
Height ⁽⁹⁾ [mm]	535		695		750	
Depth ⁽⁹⁾ [mm]	320		320		355	
Water connection	tap water of varying qualities 1 to 10bar, 1 to 10 bar, for 3/4" external thread					
Drain water connection	Connection Ø 1 1/4"					

Technical specifications FlexLine electrodes			
Unit type	FLE40-TPRO	FLE50-TPRO	FLE65-TPRO
Steam output [kg/h]	38,0 - 40,0 - 41,5	47,5 - 50,0 - 51,8	61,8 - 65,0 - 67,5
Electrical connection ⁽¹⁾	380 - 400 - 415V /3Ph /N /50-60Hz		
Rated power [kW]	28,5 - 30 - 31,1	35,6 - 37,5 - 38,9	46,3 - 48,8 - 50,6
Nominal current [A]	43,3 - 43,3 - 43,3	54,1 - 54,1 - 54,1	70,4 - 70,4 - 70,4
Fuse [A] ⁽²⁾	3 x 50	3 x 63	3 x 80
Terminals max. [mm ²]	16	25	
Number of steam cylinder	1		
Control	FlexLine TPRO mainboard with capacitive 3.5" touch colour display		
Separate control voltage ⁽³⁾	220 - 240V 2,5A		
Steam hose connection [mm]	2 x 40 ⁽⁶⁾	2 x 40	
Water consumption ⁽⁷⁾ [l/h]	49,8	62,2	81
Water flow rate ⁽⁸⁾ [l/min]	4,1 / 23,3		
Max. filling capacity [l]	20,9	35,7	
Empty weight [kg]	25,0	33,0	34,0
Operation weight [kg]	46,4	69,2	70,2
Width ⁽⁹⁾ [mm]	580	640	
Height ⁽⁹⁾ [mm]	750	785	
Depth ⁽⁹⁾ [mm]	355	420	
Water connection	tap water of varying qualities 1 to 10bar, 1 to 10 bar, for 3/4" external thread		
Drain water connection	Connection Ø 1 1/4"		

⁽¹⁾ Other voltages upon request.

⁽³⁾ Internal control voltage upon request.

⁽⁶⁾ Incl. Y-piece DN40

⁽²⁾ 13/28% above nominal power consumption after full blowdown. Observe actuation characteristics of automatic circuit-breakers. If necessary, select the next highest circuit-breaker level.

⁽⁷⁾ Maximum water consumption at 100% demand plus blowdown losses. The water consumption depends on the water quality and installed options.

⁽⁸⁾ Flow rate of the feed water during refilling or pumping out. Unit without options / maximum rate with options.

⁽⁹⁾ Outer dimensions of width and depth. Height incl. drain connection.

⁽¹¹⁾ Units with production date January 2022 and earlier: 540 mm

FLH-T

Technical data FlexLine Heater							
Unit type	FLH03-T	FLH06-T	FLH09-T	FLH15-T	FLH25-T		
Steam output [kg/h]	2,7 - 3,0 - 3,3	5,5 - 6,0 - 6,5	5,4 - 6,0 - 6,5	8,1 - 9,0 - 9,7	13,9 - 15,0 - 16,6	13,7 - 15,0 - 16,4	22,7 - 25,0 - 27,1
Electrical connection ⁽¹⁾	220 - 230 - 240V /1Ph /N /50-60Hz		380 - 400 - 415V /3Ph /N /50-60Hz		220 - 230 - 240V /1Ph /N /50-60Hz	380 - 400 - 415V /3Ph /N /50-60Hz	
Rated power [kW]	2,1 - 2,3 - 2,4	4,1 - 4,5 - 4,9	4,1 - 4,5 - 4,8	6,1 - 6,8 - 7,3	10,4 - 11,4 - 12,4	10,3 - 11,4 - 12,3	17,1 - 18,9 - 20,3
Nominal current [A]	9,4 - 9,8 - 10,2	18,7 - 19,6 - 20,4	10,7 - 11,3 - 11,7	16 - 16,9 - 17,5	47,4 - 49,6 - 51,7	15,6 - 16,5 - 17,1	25,9 - 27,3 - 28,3
Fuse [A]	1 x 16	1 x 25	3 x 16	3 x 20	1 x 63	3 x 20	3 x 32
Connection terminals max. [mm ²]	4			35		10	
Number of steam cylinder	1						
Control	FlexLine mainboard with capacitive 3.5" touch colour display						
Control voltage ⁽³⁾	220 - 240V 2,5A						
Steam hose connection [mm]	1 x 25						1 x 40
Water consumption ⁽⁷⁾ [l/h]	3,96	7,8	11,64	19,92	19,68	32,52	
Water flow rate ⁽⁸⁾ [l/min]	1,3 / 20,5			2,8 / 12,4	2,8 / 22,0		
Max. filling capacity [l]	4,8			14,0			
Empty weight [kg]	17,0			25,0			
Operation weight [kg]	22,3			39,5			
Width ⁽⁹⁾ [mm]	460			540			
Height ⁽⁹⁾ [mm]	535			695			
Depth ⁽⁹⁾ [mm]	320						
Water connection	deionized water (min. 3µS/cm) / cleaned condensate (min. 3µS/cm) / softened / tap water of varying qualities 1 to 10 bar, for 3/4' external thread						partially
Drain water connection	Connection Ø 1 1/4"						

Technical data FlexLine Heater							
Unit type	FLH30-T	FLH40-T	FLH50-T	FLH60-T	FLH80-T	FLH100-T	
Steam output [kg/h]	27,4 - 30,0 - 32,7	36,5 - 40,0 - 43,5	45,5 - 50,0 - 54,3	54,8 - 60,0 - 65,4	72,9 - 80,0 - 87,0	91,0 - 100,0 - 108,5	
Electrical connection ⁽¹⁾	380 - 400 - 415V /3Ph /N /50-60Hz						
Rated power [kW]	20,6 - 22,8 - 24,5	27,3 - 30,3 - 32,6	34,1 - 37,8 - 40,7	2 x 20,6 - 22,8 - 24,5	2 x 27,3 - 30,3 - 32,6	2 x 34,1 - 37,8 - 40,7	
Nominal current [A]	31,2 - 32,9 - 34,1	41,5 - 43,7 - 45,4	51,8 - 54,6 - 56,6	2 x 31,2 - 32,9 - 34,1	2 x 41,5 - 43,7 - 45,4	2 x 51,8 - 54,6 - 56,6	
Fuse [A]	3 x 35	3 x 50	3 x 63	2 x 3 x 35	2 x 3 x 50	2 x 3 x 63	
Connection terminals max. [mm ²]	10	35		10	35		
Number of steam cylinder	1			2			
Control	FlexLine mainboard with capacitive 3.5" touch colour display						
Control voltage ⁽³⁾	220 - 240V 2,5A						
Steam hose connection [mm]	1 x 40 ⁽⁶⁾	2 x 40			4 x 40		
Water consumption ⁽⁷⁾ [l/h]	39,24	52,2	65,16	78,48	104,4	130,2	
Water flow rate ⁽⁸⁾ [l/min]	4,1 / 23,3			2 x 4,1 / 23,3			
Max. filling capacity [l]	36,0			71,4			
Empty weight [kg]	36,0	37,0			80,0		
Operation weight [kg]	72,5	73,5			151,9		
Width ⁽⁹⁾ [mm]	640			1170			
Height ⁽⁹⁾ [mm]	785						
Depth ⁽⁹⁾ [mm]	420						
Water connection	deionized water (min. 3µS/cm) / cleaned condensate (min. 3µS/cm) / partially softened / tap water of varying qualities; 1 to 10 bar, for 3/4' external thread						
Drain water connection	Connection Ø 1 1/4"			2x Connection Ø 1 1/4"			

⁽¹⁾ Other voltages on request

⁽³⁾ Separate control voltage on request

⁽⁶⁾ Including Y-piece DN40

⁽⁷⁾ Maximum water consumption at 100% demand plus blow down losses. Water consumption depends on the water quality and options installed.

⁽⁸⁾ Flow rate of the feed water when refilling or pumping out. Device without options / maximum rate with options

⁽⁹⁾ Outer dimensions of width and depth. Height including drain connection

FLH-TRPO

Technical data FlexLine Heater							
Unit type	FLH03-TPRO	FLH06-TPRO		FLH09-TPRO	FLH15-TPRO		FLH25-TPRO
Steam output [kg/h]	2,7 - 3,0 - 3,3	5,5 - 6,0 - 6,5	5,4 - 6,0 - 6,5	8,1 - 9,0 - 9,7	13,9 - 15,0 - 16,6	13,7 - 15,0 - 16,4	22,7 - 25,0 - 27,1
Electrical connection ⁽¹⁾	220 - 230 - 240V /1Ph /N /50-60Hz		380 - 400 - 415V /3Ph /N /50-60Hz		220 - 230 - 240V /1Ph /N /50-60Hz		380 - 400 - 415V /3Ph /N /50-60Hz
Rated power [kW]	2,1 - 2,3 - 2,4	4,1 - 4,5 - 4,9	4,1 - 4,5 - 4,8	6,1 - 6,8 - 7,3	10,4 - 11,4 - 12,4	10,3 - 11,4 - 12,3	17,1 - 18,9 - 20,3
Nominal current [A]	9,4 - 9,8 - 10,2	18,7 - 19,6 - 20,4	10,7 - 11,3 - 11,7	16 - 16,9 - 17,5	47,4 - 49,6 - 51,7	15,6 - 16,5 - 17,1	25,9 - 27,3 - 28,3
Fuse [A]	1 x 16	1 x 25	3 x 16	3 x 20	1 x 63	3 x 20	3 x 32
Connection terminals max. [mm ²]	4				35	10	
Number of steam cylinder	1						
Control	FlexLine TPRO mainboard with capacitive 3.5" touch colour display						
Control voltage ⁽³⁾	220 - 240V 2,5A						
Steam hose connection [mm]	1 x 25						1 x 40
Water consumption ⁽⁷⁾ [l/h]	3,96	7,8		11,64	19,92	19,68	32,52
Water flow rate ⁽⁸⁾ [l/min]	1,3 / 20,5				2,8 / 12,4	2,8 / 22,0	
Max. filling capacity [l]	4,8				14,0		
Empty weight [kg]	17,0				25,0		
Operation weight [kg]	22,3				39,5		
Width ⁽⁹⁾ [mm]	460				540		
Height ⁽⁹⁾ [mm]	535				695		
Depth ⁽⁹⁾ [mm]	320						
Water connection	fully demineralised water (min. 3µS/cm conductivity) 1 to 10 bar, for 3/4" external thread						
Drain water connection	Connection Ø 1 1/4"						

Technical data FlexLine Heater			
Unit type	FLH30-TPRO	FLH40-TPRO	FLH50-TPRO
Steam output [kg/h]	27,4 - 30,0 - 32,7	36,5 - 40,0 - 43,5	45,5 - 50,0 - 54,3
Electrical connection ⁽¹⁾	380 - 400 - 415V /3Ph /N /50-60Hz		
Rated power [kW]	20,6 - 22,8 - 24,5	27,3 - 30,3 - 32,6	34,1 - 37,8 - 40,7
Nominal current [A]	31,2 - 32,9 - 34,1	41,5 - 43,7 - 45,4	51,8 - 54,6 - 56,6
Fuse [A]	3 x 35	3 x 50	3 x 63
Connection terminals max. [mm ²]	10	35	
Number of steam cylinder	1		
Control	FlexLine TPRO mainboard with capacitive 3.5" touch colour display		
Control voltage ⁽³⁾	220 - 240V 2,5A		
Steam hose connection [mm]	1 x 40 ⁽⁶⁾	2 x 40	
Water consumption ⁽⁷⁾ [l/h]	39,24	52,2	65,16
Water flow rate ⁽⁸⁾ [l/min]	4,1 / 23,3		
Max. filling capacity [l]	36,0		
Empty weight [kg]	36,0	37,0	
Operation weight [kg]	72,5	73,5	
Width ⁽⁹⁾ [mm]	640		
Height ⁽⁹⁾ [mm]	785		
Depth ⁽⁹⁾ [mm]	420		
Water connection	deionized water (min. 3µS/cm conductivity) 1 to 10 bar, for 3/4" external thread		
Drain water connection	Connection Ø 1 1/4"		

⁽¹⁾ Other voltages on request

⁽³⁾ Separate control voltage on request

⁽⁶⁾ Including Y-piece DN40

⁽⁷⁾ Maximum water consumption at 100% demand plus blow down losses. Water consumption depends on the water quality and options installed.

⁽⁸⁾ Flow rate of the feed water when refilling or pumping out. Device without options / maximum rate with options

⁽⁹⁾ Outer dimensions of width and depth. Height including drain connection

FLP-T

Technical specifications FlexLinePlus heater							
Unit type	FLP05-T	FLP08-T	FLP15-T	FLP25-T	FLP30-T	FLP40-T	FLP50-T
Steam output [kg/h]	4,6 - 5,0 - 5,5	7,6 - 8,0 - 9,0	13,7 - 15,0 - 16,4	22,7 - 25,0 - 27,1	27,4 - 30,0 - 32,7	36,5 - 40,0 - 43,5	45,5 - 50,0 - 54,3
Electrical connection ⁽¹⁾	380 - 400 - 415V /3Ph /N /50-60Hz						
Rated power [kW]	3,4 - 3,8 - 4,1	5,7 - 6,3 - 6,8	10,3 - 11,4 - 12,3	17,1 - 18,9 - 20,3	20,6 - 22,8 - 24,5	27,3 - 30,3 - 32,6	34,1 - 37,8 - 40,7
Nominal current [A]	9 - 9,5 - 9,9	15 - 15,8 - 16,3	15,6 - 16,5 - 17,1	25,9 - 27,3 - 28,3	31,2 - 32,9 - 34,1	41,5 - 43,7 - 45,4	51,8 - 54,6 - 56,6
Fuse [A]	3 x 16	3 x 20		3 x 32	3 x 35	3 x 50	3 x 63
Terminals max. [mm ²]	4		10			35	
Number of steam cylinder	1						
Control	FlexLine mainboard with capacitive 3.5" touch colour display						
Separate control voltage ⁽³⁾	220 - 240V 2,5A						
Steam hose connection [mm]	1 x 25 ⁽⁵⁾			1 x 40	1 x 40 ⁽⁶⁾	2 x 40	
Water consumption ⁽⁷⁾ [l/h]	6,6	10,8	19,68	32,52	39,24	52,2	65,16
Water flow rate ⁽⁸⁾ [l/min]	2,8 / 22,0				4,1 / 23,3		
Max. filling capacity [l]	15,0				30,0		
Empty weight [kg]	32,0		35,0			41,0	
Operation weight [kg]	47,5		50,5			71,5	
Width ⁽⁹⁾ [mm]	650						
Height ⁽⁹⁾ [mm]	855						
Depth ⁽⁹⁾ [mm]	380						
Water connection	deionized water (min. 3µS/cm conductivity) / cleaned condensate (min. 3µS/cm conductivity) / softened water / tap water of varying qualities; 1 to 10 bar, for 3/4" external thread						
Drain water connection	Connection Ø 1 1/4"						

FLP-TPRO

Technical specifications FlexLinePlus heater							
Unit type	FLP05-TPRO	FLP08-TPRO	FLP15-TPRO	FLP25-TPRO	FLP30-TPRO	FLP40-TPRO	FLP50-TPRO
Steam output [kg/h]	4,6 - 5,0 - 5,5	7,6 - 8,0 - 9,0	13,7 - 15,0 - 16,4	22,7 - 25,0 - 27,1	27,4 - 30,0 - 32,7	36,5 - 40,0 - 43,5	45,5 - 50,0 - 54,3
Electrical connection ⁽¹⁾	380 - 400 - 415V /3Ph /N /50-60Hz						
Rated power [kW]	3,4 - 3,8 - 4,1	5,7 - 6,3 - 6,8	10,3 - 11,4 - 12,3	17,1 - 18,9 - 20,3	20,6 - 22,8 - 24,5	27,3 - 30,3 - 32,6	34,1 - 37,8 - 40,7
Nominal current [A]	9 - 9,5 - 9,9	15 - 15,8 - 16,3	15,6 - 16,5 - 17,1	25,9 - 27,3 - 28,3	31,2 - 32,9 - 34,1	41,5 - 43,7 - 45,4	51,8 - 54,6 - 56,6
Fuse [A]	3 x 16	3 x 20		3 x 32	3 x 35	3 x 50	3 x 63
Terminals max. [mm ²]	4		10			35	
Number of steam cylinder	1						
Control	FlexLine TPRO mainboard with capacitive 3.5" touch colour display						
Separate control voltage ⁽³⁾	220 - 240V 2,5A						
Steam hose connection [mm]	1 x 25 ⁽⁵⁾			1 x 40	1 x 40 ⁽⁶⁾	2 x 40	
Water consumption ⁽⁷⁾ [l/h]	6,6	10,8	19,68	32,52	39,24	52,2	65,16
Water flow rate ⁽⁸⁾ [l/min]	2,8 / 22,0				4,1 / 23,3		
Max. filling capacity [l]	15,0				30,0		
Empty weight [kg]	32,0		35,0			41,0	
Operation weight [kg]	47,5		50,5			71,5	
Width ⁽⁹⁾ [mm]	650						
Height ⁽⁹⁾ [mm]	855						
Depth ⁽⁹⁾ [mm]	380						
Water connection	deionized water (mind. 3µS/cm conductivity) 1 to 10 bar, for 3/4" external thread						
Drain water connection	Connection Ø 1 1/4"						

⁽¹⁾ Other voltages upon request

⁽³⁾ Internal control voltage upon request

⁽⁵⁾ Reducer DN40/DN25 included

⁽⁶⁾ Incl. Y-piece DN40

⁽⁷⁾ Maximum water consumption at 100% demand plus blowdown losses. The water consumption depends on the water quality and installed options.

⁽⁸⁾ Flow rate of the feed water during refilling or pumping out. Unit without options / maximum rate with options.

⁽⁹⁾ Outer dimensions of width and depth. Height incl. drain connection.

HyGROMATIK[®]
member of CAREL group 

Lise-Meitner-Str.3 • D-24558 Henstedt-Ulzburg
Phone +49(0)4193/ 895-0 • Fax -33
eMail hy@hygromatik.de • www.hygromatik.com
member of **CAREL Group**

