



HygroMATIK[®]
WE HUMIDIFY THE AIR

humiFog direct

Adiabatic high-pressure atomiser
for direct room humidification



- Reliable complete solution which simultaneously humidifies and cools
- Flexible in use, ideal for retrofitting
- Simple and fast installation
- Low energy consumption
- Intuitive operation
- Future-proof connectivity (GLT)



Humidification for best conditions
for industry, manufacturing processes, public buildings and offices

Adiabatic direct room humidification

Stabilisation of the air humidity for quality and process safety

Direct room air humidification – flexible and independent.

The air humidity in a room has a decisive influence on the room climate. Sensitive production processes or the storage of hygroscopic materials such as paper, wood or fabric can be optimised by controlling the humidity.

Direct room humidifiers are used for quality and process assurance as well as for the reduction of disturbance factors (e.g. dust, electrostatic charges) in the following areas of application:

- Wood industry
- Paper production / processing
- Textile industry
- Food and beverage industry (tobacco, fruit, vegetables, meat, cheese, etc.)

Direct room air humidification is a simple and flexible way to professionally control the humidity in rooms. Space-saving complete systems for direct room air humidification offer many advantages:

- Quick and flexible installation directly in the humidification environment
- Ideal for small to medium-sized rooms and buildings, as there is no central ventilation and air-conditioning system necessary
- Extension and optimisation by external controllers or sensors possible
- Uncomplicated retrofitting of the adiabatic systems



Adiabatic air humidification – efficient and intelligent.

In commercial and industrial applications waste heat is often generated by the process which usually has to be dissipated or regulated in a costly and energy-intensive manner. By using adiabatic humidification systems, a cooling effect is also achieved which reduces this heat without additional energy input.

The principle is simple and clever: with adiabatic humidification, microscopic water droplets evaporate in the air. The change in state from liquid to gaseous withdraws energy from the ambient air in the form of heat. This cools the air and the ambient temperature drops.



A positive side effect: refrigeration plants can be equipped or operated with less power – **this reduces energy and investment costs.**

With **CAREL humiFog direct** we offer an adiabatic direct room humidifier which ensures a controllable and stable humidity in the humidification environment and at the same time reduces existing waste heat in an energy-efficient manner.



**Adiabatic direct room humidification:
Efficient humidification and cooling**

CAREL humiFog direct as a complete solution

Adiabatic high-pressure atomiser for direct room air humidification

A powerful system – flexible use in any environment.

CAREL humiFog direct is a high-pressure atomising system for adiabatic room humidification. It was developed for industrial environments and combines maximum reliability with minimum operating costs. This efficient system is easy to install and suitable for any environment, however complex.

Pure water is atomised into the finest mist which spontaneously evaporates and at lowest energy consumption the right humidity level secures. The CAREL humiFog direct guarantees hygienic safety because only fully demineralised water is atomised and the pipes are cleaned automatically.



Single-side



Double-side

2. Blower units

The blower units distribute the smallest water droplets in the environment – exactly where humidification is required. The strong air flow of the fans supports the spontaneous absorption of the droplets under all temperature and humidity conditions.

- **Freely combinable:** The fan units can atomise in one direction (single-side) or in two opposite directions (double-side). They are available with 2 to 8 nozzles in different capacities (1.45, 2.8 and 4 l/h per nozzle).
- **Easy to install:** The system components are delivered already assembled and tested. The mounting systems are quick and easy to install.
- **Flexible to position:** The blower units can be mounted on the ceiling or wall for precise humidification.
- **Safe:** The anti-dripping system prevents dripping when the system is switched off.

3. High pressure pipes

The installation of CAREL humiFog direct is simplified by a high-pressure pipe kit. The plastic pipes are flexible and resistant to high pressure.

They enable **quick assembly** and significantly reduce installation times. In addition, tailor-made solutions for adaptation to different application frame conditions can be implemented.

4. Sensors (wireless and cable)

Each zone can work with **up to four sensors**. In this way, humidity or temperature are measured in large or complex environments more precisely controlled.

Sliding operation with a maximum hygostat prevents the exceeding of preset humidity values in certain areas in order to avoid local condensate formation and thus possible consequential damage can be safely avoided.

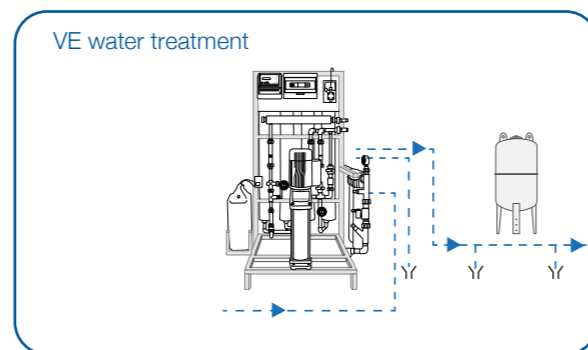

1. Control box with powerful pump station

This generates a constant water pressure of 70 bar for highest performance at lowest energy consumption. **Up to two zones** can be humidified with different setpoints.

The modular design also ensures that the system can be expanded to meet any humidification requirement.

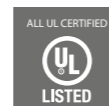
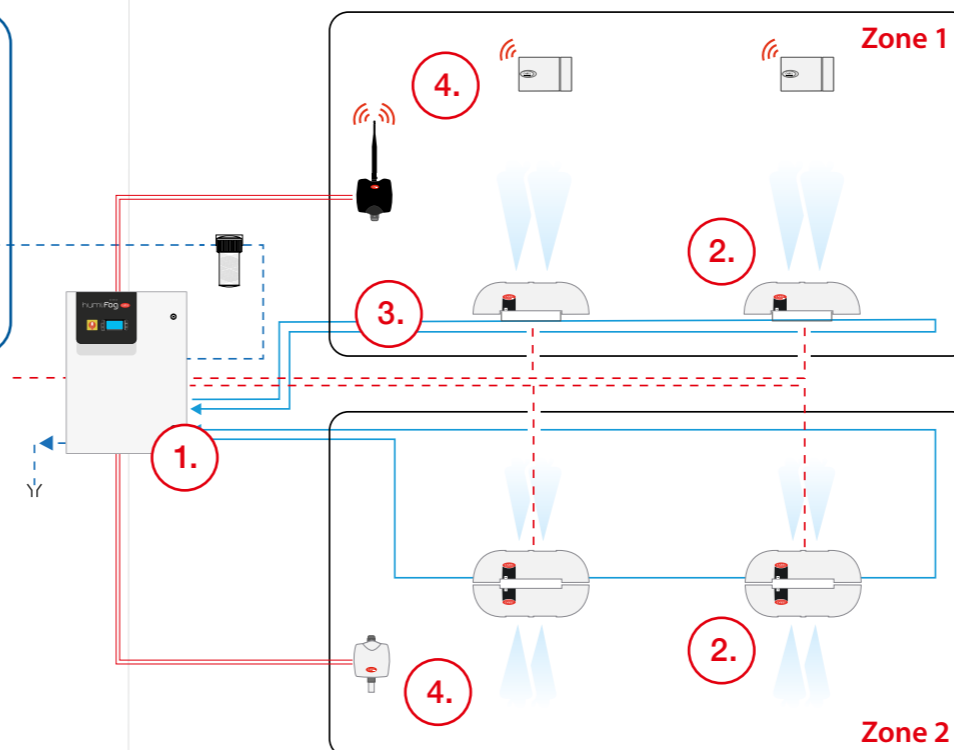

CAREL humiFog direct – fit for the future

Electronic control: maximum connectivity and reliability

Smart, digital and reliable – accessible from anywhere at any time.

CAREL humiFog direct's **c.pHC electronic control unit** ensures fast commissioning, easy operation and maximum system reliability.

Commissioning assistant



Simple, fast and assisted configuration of the basic parameters for the first device commissioning.

USB connection



An integrated USB port provides instant access to various functions such as saving the alarm log, copy and paste configuration parameters for quick installation of multiple devices and software updates directly on site.

Web server



Direct access to the device display from any PC or tablet in the local humidifier network allows any configuration to be displayed as if directly on the device itself – including controls, settings and device status.



Monitoring

The standard communication protocols are Modbus, BACnet and CAREL for the serial BMS connection and Modbus and BACnet also for the Ethernet connection.



tERA ready

Once the service has been activated via the Ethernet connection, the system can be monitored and controlled remotely.



Redundancy and rotation

The redundancy and rotation functions via the Ethernet network ensure uninterrupted plant operation even in the event of a plant failure, e.g. in the case of maintenance. When operating multiple pump systems simultaneously, rotation logic can be implemented to minimise maintenance.



Overview of CAREL humiFog direct functions

Automatic cleaning cycles	✓	USB connection	✓
Master/slave function	✓	tERA ready	✓
Redundancy and rotation	✓	Commissioning assistant	✓
Wireless sensor	✓	Planner	✓
Web server	✓	Modulating limit sensor	✓
BACnet, Modbus and CAREL protocols	✓	Pulse width modulation	✓

Notes on installation CAREL humiFog direct

Minimum distances between blower units

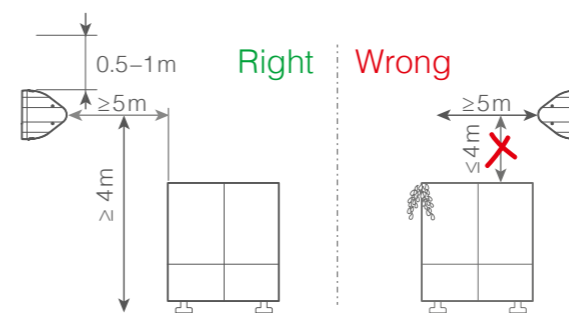

Radio range of the wireless sensors

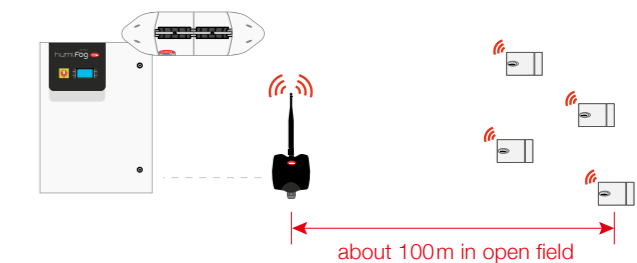

Technical specifications CAREL humiFog direct

A higher humidification performance is possible by connecting units together.

Type	UA040	UA080
Nominal power l/h	40	80
Electrical connection [V/Hz]	230V, 1-phase, 50 Hz	
Rated power [kW]	0.28	
Weight [kg]	60 - 68	
Width x height x depth [mm]	630 x 800 x 300	
Water inlet [inch]	3/4"	
Water outlet [inch]	1/4"	

We reserve the right to make technical changes.

Our service for 100% customer satisfaction

- Long availability for replacement parts
- Technical hotline +49 4193 895-293
or hotline@hygromatik.com
- HygroMatik distributes in more than 45 countries
- Operating manuals, planning data and information
on workshop events available online at
www.hygromatik.com



HYGROMATIK[®]
WE HUMIDIFY THE AIR

HygroMatik GmbH
Lise-Meitner-Str. 3
24558 Henstedt-Ulzburg
Germany

T +49 4193 895-0
F +49 4193 895-33
hy@hygromatik.de
www.hygromatik.com

member of **CAREL group**