

## Steam Injection Humidifiers DDS

for existing steam systems



MANUAL



DDS.EN  
E-8881128

Copyright © HygroMatik GmbH [25.01.2022]

Steam Injection Humidifiers / DDS EN

Information in this manual is subject to change or alteration without prior notice.

**⚠ WARNING**

**Risk of electrical shock!**

Hazardous electrical high voltage!

All electrical work to be performed by certified expert staff (electricians or expert personnel with equivalent training) only.

<b>1. Introduction</b> .....	<b>5</b>
1.1 Typographic Distinctions .....	5
1.2 Documentation .....	5
1.3 Symbols in Use .....	5
1.3.1 Specific Symbols related to Safety Instructions .....	5
1.3.2 General Symbols .....	5
1.4 Intended Use .....	6
<b>2. Safety Instructions</b> .....	<b>7</b>
2.1 Guidelines for Safe Operation .....	7
2.1.1 Scope .....	7
2.1.2 Unit control .....	7
2.1.3 Mounting, dismantling, maintenance and repair of the unit .....	8
2.1.4 Electrical .....	8
2.2 Disposal after dismantling .....	9
<b>3. Transport</b> .....	<b>10</b>
3.1 Overview .....	10
3.2 Packing .....	10
3.3 Interim Storage .....	10
3.4 Check for Complete and Correct Delivery of Goods .....	10
<b>4. Function and Assembly</b> .....	<b>11</b>
4.1 Areas of application .....	11
4.2 Function .....	11
4.3 Components .....	13
4.3.1 Separator .....	13
4.3.2 Strainer .....	14
4.3.3 Control Valve and Actuator .....	14
4.3.4 Start-up safety switch .....	16
4.3.5 Steam Lances .....	17
4.3.6 Pressure Gauge Station .....	18
4.3.7 Ball Float Steam Trap .....	19
4.3.8 Thermostatic Capsule Steam .....	20
<b>5. Humidification Output</b> .....	<b>21</b>
5.1 Output Graphs .....	21
5.2 Determining the control valve Kvs-Value .....	21
5.3 Separator Type 20 with one steam lance .....	22
5.4 Separator Type 20 with multiple steam lances .....	23
5.5 Separator Type 40 with one steam lance .....	24
5.6 Separator Type 40 with multiple steam lances .....	25
<b>6. Graph for Determining Absorption Distance</b> .....	<b>26</b>
<b>7. Mechanical installation</b> .....	<b>27</b>
7.1 Allowable environmental parameters .....	27
7.2 Attaching steam pipes .....	27
7.3 Installing the steam pipes .....	28

- 7.3.1 Water hammer prevention ..... 28
- 7.4 Separator ..... 29
- 7.5 Control Valve and Actuator ..... 29
- 7.6 Pneumatic Start-up safety feature ..... 30
- 7.7 Steam Lances ..... 30
  - 7.7.1 Duct mounting set for steam lance ..... 31
  - 7.7.2 Installation Examples ..... 32
- 7.8 Steam Lance Heating System ..... 35
- 7.9 Check List ..... 36
- 8. Electrical connection ..... 37**
- 9. Commissioning ..... 39**
- 10. Maintenance ..... 41**
  - 10.1 Strainer ..... 41
  - 10.2 Ball float condensate drain ..... 42
  - 10.3 Thermostatic Capsule Steam trap Type MST21 ..... 42
- 11. Malfunctions ..... 43**
- 12. Dimensions and Installation Schematic ..... 45**
- 13. Spare Parts ..... 47**
- 14. Technical Data ..... 50**

## 1. Introduction

### Dear Customer,

Thank you for choosing a HygroMatik steam injection humidifier.

HygroMatik steam humidifiers represent the latest in humidification technology.

In order to operate your HygroMatik steam injection humidifier safely, properly and efficiently, please read these operating instructions.

Employ your steam injection humidifier only in sound condition and as directed. Consider potential hazards and safety issues and follow all the recommendations in these instructions.

If you have additional questions, please contact your expert dealer.

For all technical questions or spare parts orders, please be prepared to provide unit type and serial number (see name plate on the unit).

### 1.1 Typographic Distinctions

- Preceded by a bullet: general specifications
- » Preceded by an arrow: procedures for servicing or maintenance which should or must be performed in the indicated order
- ☑ Installation step which must be checked off.

*italics* Terms used with graphics or drawings

### 1.2 Documentation

#### Retention

Please retain these operating instructions in a secure, always accessible location. If the product is resold, turn the documentation over to the new operator. If the documentation is lost, please contact HygroMatik.

### Versions in Other Languages

These operating instructions are available in several languages. If interested, please contact HygroMatik or your HygroMatik dealer.

## 1.3 Symbols in Use

### 1.3.1 Specific Symbols related to Safety Instructions

According to ANSI Z535.6 the following signal words are used within this document:

#### **▲ DANGER**

DANGER indicates a hazardous situation which, if not avoided, will result in death or serious injury.

#### **▲ WARNING**

WARNING indicates a hazardous situation which, if not avoided, could result in death or serious injury.

#### **▲ CAUTION**

CAUTION indicates a hazardous situation which, if not avoided, could result in minor or moderate injury.

#### **NOTICE**

NOTICE is used to address practices not related to physical injury.

### 1.3.2 General Symbols

#### **Please note**

This symbol is used whenever a situation requires special attention beyond the scope of safety instructions.

## 1.4 Intended Use

### Areas of application:

The HygroMatik steam injection humidifier (SIH) uses existing pressurized steam for air humidification. The SIH humidifies with condensate-free saturated steam and offers the shortest possible humidification distances. They are used e.g. in clean rooms and hospitals.

Proper usage also comprises the adherence to the conditions specified by HygroMatik for:

- installation
- dismantling
- reassembly
- commissioning
- operation
- maintenance
- disposal

Only qualified and personnel may work on or with the system (a supplementary qualification according to VDI 6022 Part B or an equivalent qualification is recommended). Persons transporting or working on or with the system must have read and understood the relevant parts of this operating manual, particularly the 'Safety instructions' section. Staff must also be informed of possible hazards by the operating company. Please keep a copy of the operating manual at the location where the device is being used.

### **NOTICE**

Components installed in ventilation and air-conditioning systems must be suitable for the intended use; i.e., according to VDI 6022 or equivalent, they must be corrosion-resistant, easy to clean, accessible and hygienic. Furthermore, they must not facilitate growth of micro-organisms.

### **NOTICE**

By construction, HygroMatik steam injection humidifiers are not qualified for exterior application.

The room temperature during operation of the system should be between 5 and 40 °C.

---

### Improper use:

Any other use not compatible with the intended use outlined above is not allowable. Improper use as well as changes in hardware or software that are not authorized by HygroMatik will lead to the total loss of guarantee and warranty claims.

---

## 2. Safety Instructions

These safety instructions are required by law. They promote workplace safety and accident prevention.

### 2.1 Guidelines for Safe Operation

#### 2.1.1 Scope

Comply with the accident prevention regulation „DGUV Regulation 3“ to prevent injury to yourself and others. Beyond that, national regulations apply without restrictions.

#### 2.1.2 Unit control

Do not perform any work which compromises the safety of the unit. Obey all safety instructions and warnings present on the unit.

In case of a malfunction or electrical power disruption, switch off the unit immediately and prevent a restart. Repair malfunctions promptly. Close the steam supply line and secure it against unauthorized reopening. After repair work, ensure the operational safety of the steam injection humidifier by qualified personnel. Regularly check that all safety and monitoring devices are functioning normally. Do not remove or disable safety devices.

### **NOTICE**

#### **Risk of material damage!**

The unit may be damaged if switched on repeatedly following a malfunction without prior repair.

#### **Rectify defects immediately!**

Use only original spare parts.

### **▲WARNING**

#### **Restricted use.**

According to IEC 60335-2-98 the following applies: Very young children must not use the device. Children are not allowed to play with the device, this must be ensured by a supervisor. Children are not allowed to do cleaning and user maintenance without a supervision.

---

### 2.1.3 Mounting, dismantling, maintenance and repair of the unit

#### **⚠ CAUTION**

- Use only steam with a minimum pressure of 0,5 barg and a maximum pressure of 4,5 barg at the entry point of the steam injection humidifier.
- Steam pipes are hot and care must be taken accordingly.
- Use only steam without chemical additives.
- Steam supply must be dimensioned so that the steam velocity does not exceed 25 m/s.
- The control valves are not stop valves. They have been optimised to control the necessary steam supply. They are metal to metal sealed according to IEC 534-4 Class IV and can, therefore, show a leakage of 0.01 % when supplied. We recommend the use of a stop valve in order to ensure that the steam supply is completely shut off.
- There may be impurities in the steam supply. In order to prevent valve damage there must be a filter installed with a pore diameter of <0.16 mm.
- During maintenance or installation work, the device must be disconnected from the power supply and secured against being switched on again. The absence of voltage must be ensured by a measurement.
- To enable constant and steady humidification, the humidity sensors should not be mounted in the supply air duct.
- Use genuine spare parts only.
- After electrical installation or repair work, test all safety mechanisms (such as grounding resistance) and ensure operational safety through competent and qualified staff.
- Attaching or installing of **additional components** is permitted only with the **written consent** of the manufacturer.

#### **NOTICE**

**Water leaks caused by defective connections or malfunctions are possible.**

Water is constantly and automatically filled and drained in the humidifier. Connections and water-carrying components must be checked regularly for correct operation.

Do not install HygroMatik steam generators above electrical equipment such as fuse boxes, electrical appliances, etc. In the case of a leakage, leaking water can damage the underlying electrical equipment.

### 2.1.4 Electrical

#### **⚠ WARNING**

**Risk of electrical shock!**

Hazardous electrical voltage!

- Any work on the electrical system to be performed by certified expert staff (electricians or expert personnel with comparable training) only.
- During maintenance or installation work, the device must be disconnected from the power supply and secured against being switched on again. The absence of voltage must be ensured by a measurement.
- After electrical installation or repair work, test all safety mechanisms (such as grounding resistance).



**NOTICE**

- Use only original fuses with the appropriate amperage rating.
  - Regularly check the unit's electrical equipment. Promptly repair any damage such as loose connections or burned wiring.
  - Responsibility for intrinsically safe installation of the HygroMatik steam humidifiers is incumbent on the installing specialist company.
- 

## 2.2 Disposal after dismantling

The humidifier is made up of metal parts and plastic parts. In reference to European Union directive 2012/19/EU issued on 4 July 2012 and the related national legislation, please note that:

The components of the electrical and electronic devices must not be disposed of as municipal waste, and therefore the method of waste separation must be applied. The public or private waste collection systems defined by local legislation must be used.

**NOTICE**

The operator is responsible for the disposal of unit components as required by law.

### 3. Transport

#### 3.1 Overview

**Please note**

Proceed carefully when transporting the steam injection humidifier in order to prevent damage due to stress or careless loading and unloading.

#### 3.2 Packing

The type of packaging depends on the series and type of the delivered device.

Accessories (e.g. steam traps) are packed separately.

If the control valve is included in the scope of delivery, it is delivered mounted with the actuator and connected to the steam dryer. Additional fittings are packed separately.

The steam lances are delivered in special protective coatings.

#### 3.3 Interim Storage

Store the unit in a dry place and protect from frost and strong sunlight.

**Please note**

Only clean components are permitted to be installed in a ventilation duct.

#### 3.4 Check for Complete and Correct Delivery of Goods

Upon receipt of the unit, confirm that:

- model and serial number on the name plate match those specified in the order and delivery documents
- the equipment is complete and all parts are in perfect condition

**Please note**

In case of damage from shipment and/or missing parts, immediately notify the carrier or supplier in writing.

Time limits for filing freight claims with shipping companies are\*:

Shipping company	After receipt of goods
Carriers	no later than 4 days
Parcel service	immediately

\* Time limits for some services subject to change.

## 4. Function and Assembly

### 4.1 Areas of application

The typical use of the HygroMatik DDS pressurized steam humidifier is for supply air humidification. The system is connected to an existing steam network and humidifies with condensate-free saturated steam. It thus offers the shortest possible humidification distances.

The HygroMatik DDS offers four components in one unit: Separator, strainer condensation drain and start-up safety switch.

### 4.2 Function

Steam flows through a **dirt particle trap (1)** over the **Separator interface (2)** into the **Separator (3)**. The separator separates condensation from the steam.

Condensation is drained using the **float controlled condensation drainage (4)**. The **Start-up safety feature (5)** measures the temperature at the condensation return. **Operation switch (11)** is activated when the switch temperature has reached approx. 80°C.

Now the main portion of the steam flows through the **control valve (7)**. The amount of steam is regulated over the operation switch (11).

**Steam lance (s) (8)** are flanged or screwed onto the valve exit side.

Dried steam is blown out through the specially formed **nozzles (9)** that take the dried steam from the pipe centre. The nozzles are press-fitted into the steam lances.

The steam lance heating system is fed over **connection (6)** on the separator. Alternatively there is the possibility to seal the separator connection and operate the steam lance heating system from a separate steam reservoir. A thermic **Capsule Condensation Drain (10)** ensures that condensation in the steam lance heating system is drained off.

**SIH Version C  
(MaterialMix)**

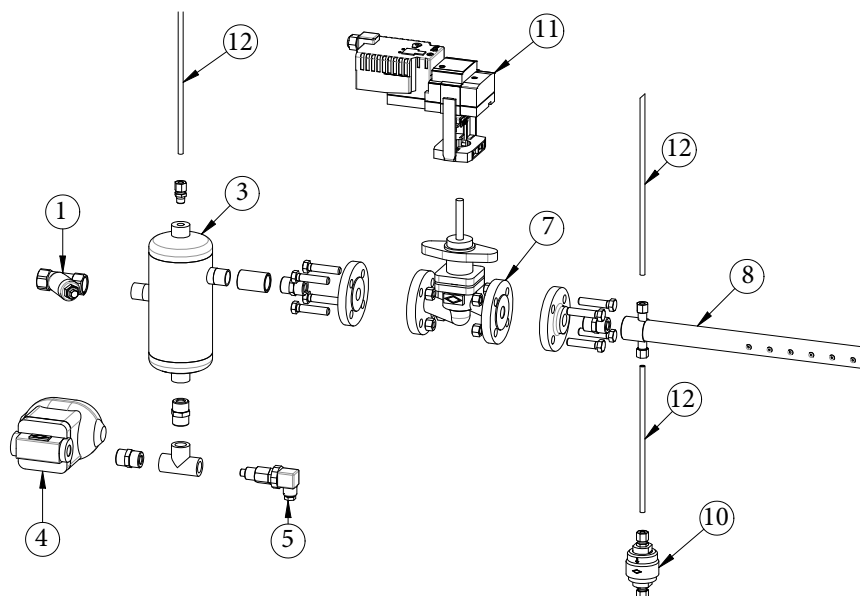

**SIH Version C (Material Mix)**

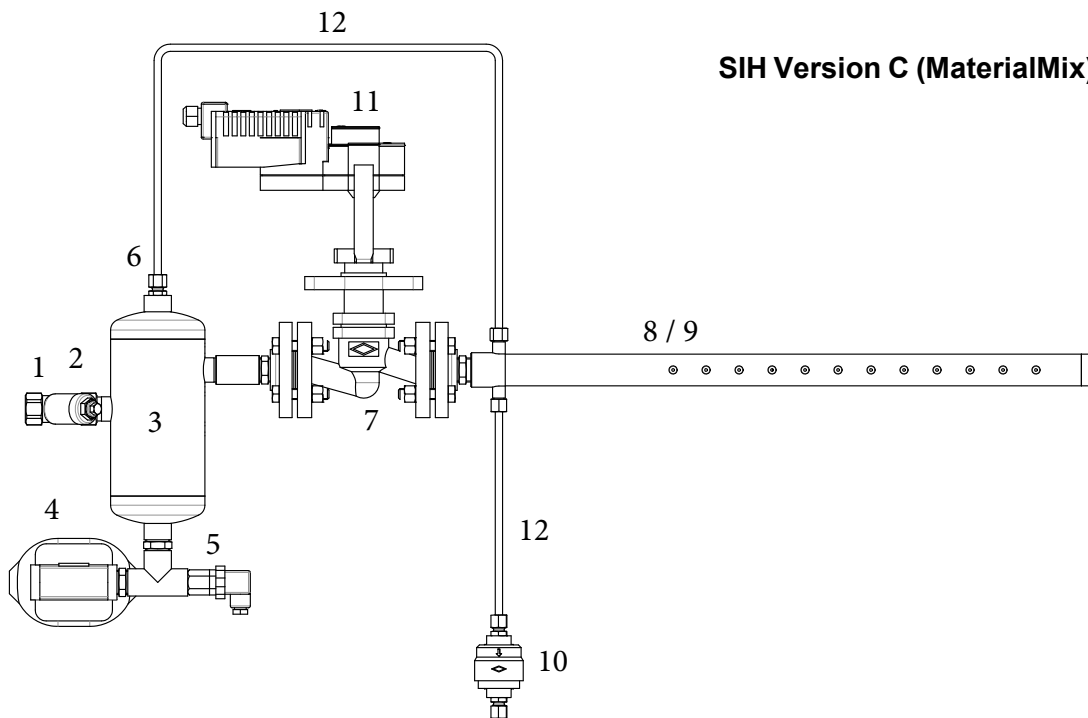

**SIH Version C (MaterialMix)**

- 1 - dirt particle trap
- 2 - Separator interface
- 3 - Separator
- 4 - Float controlled Condensation Drain
- 5 - Start-up safety feature
- 6 - connection

- 7- control valve
- 8 - Steam lance (s)
- 9 - Nozzles
- 10 - Thermic Capsule Condensation Drain
- 11 - Operation switch
- 12 - steam lance heating system

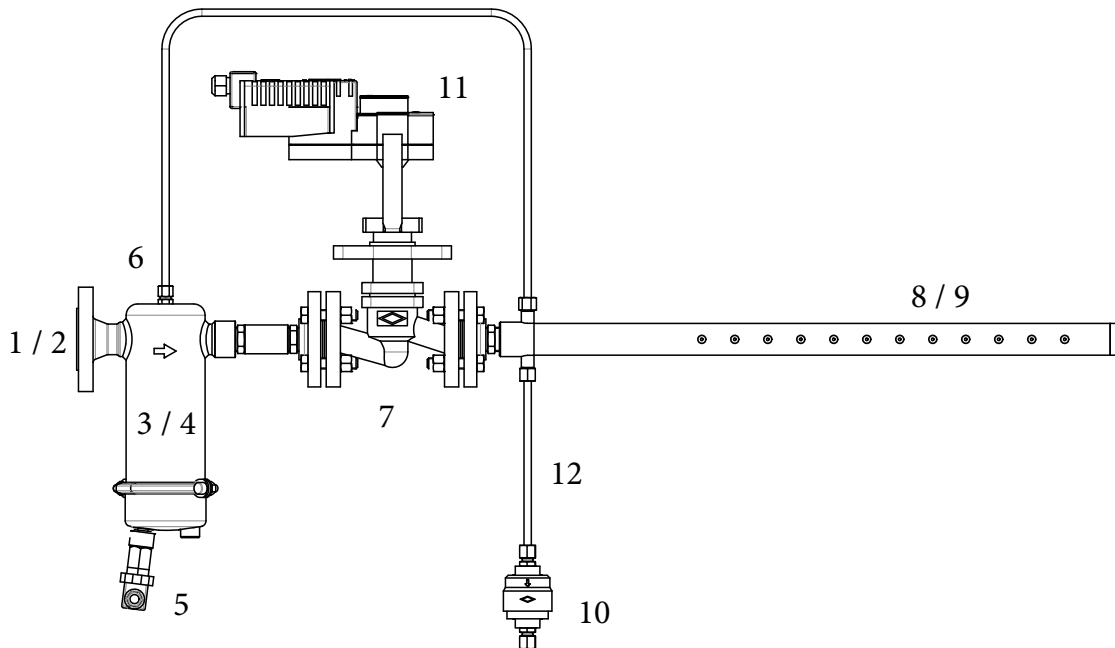

**SIH Version A (stainless steel)**

### 4.3 Components

The HygroMatik pressure steam humidifier consists of 4 basic elements:

- Separator
- Control valve with or without actuator
- Steam Plants
- Accessories

The system is available completely in stainless steel (A) or as a material-mix version (C).

#### 4.3.1 Separator

The stainless steel separator is the essential component for moisture separation. The separator is available in versions 20 and 40. The separator size is dependent upon the desired steam output and available steam pressure.

#### Separator Version C

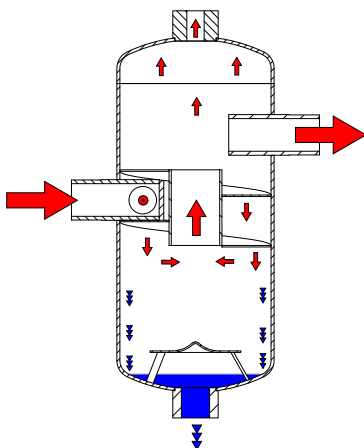

#### Separator Version A



### Function

Steam flows through the **pipe union (1)** into the separator.

Steam and condensate are separated by the joint action of the **inlet pipe (2)** and the spiral-shaped flow system.

The aerosole droplets present in the steam are thrown against the outer wall by centrifugal force which separates them from the steam phase. The droplets are conveyed through the **drain (3)** into the condensate return. This prevents droplets from being transported by the steam.

Steam is conveyed into the upper part of the separator chamber via a **supply pipe (4)** or directly to the valve.

A certain amount of steam flows through the **connector (5)** and feeds the steam lance heating system.

The bulk of the steam exits the separator through the **outlet connection (6)** and flows through the control valve.

#### Separator Version A

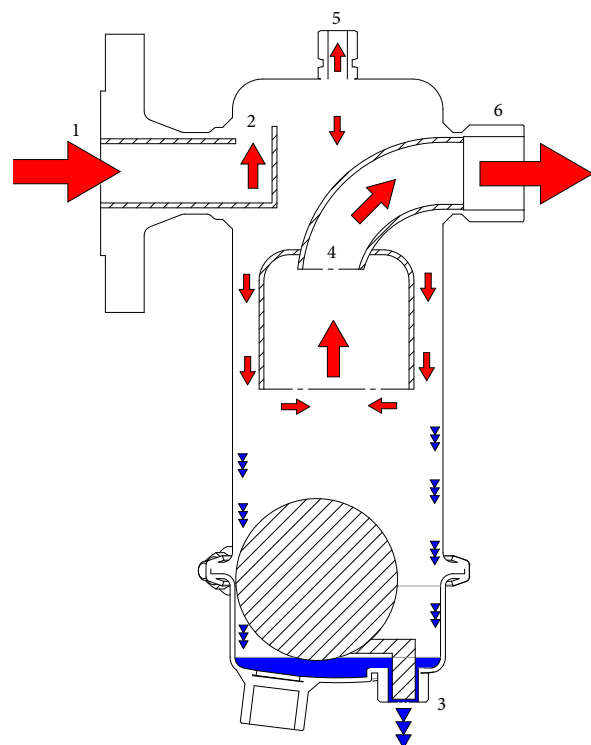

### 4.3.2 Strainer

There should be a strainer installed in the steam supply line directly in front of every separator. Only if this is done there is guarantee that no foreign particles enter the humidifier unit.

Valve cone and valve face in both the control valve and steam trap are sensitive to fouling. Dirt particles between the face and the cone prevent normal closure and have a corrosive effect.

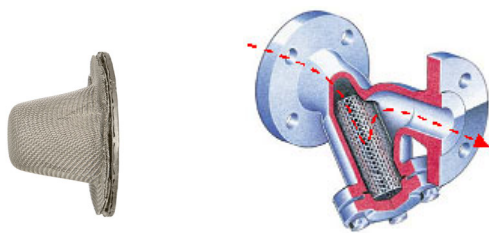

SIH Type A

Principle description  
SIH Type C

#### Function

Steam flows through the inlet in the cylindrical version (type C) or the conical strainer (type A) and through the holes to the exit. Foreign matter is retained by the strainer.

### 4.3.3 Control Valve and Actuator

The desired steam quantity is set over a control valve, which is located between separator and steam lance. The control valve itself is controlled by an electrical or pneumatic actuator.

If control valve and actuator are included in the delivery the relevant operating and installation instructions will be enclosed.

If control units from other manufacturers are used the customer must check whether these are compatible with the steam injection humidifier.

### Control valve

The control valve regulates the steam quantity by means of the valve lift. When the valve is closed the valve cone rests against the valve face. When the valve rods lift the cone there is a resultant gap through which the desired quantity of steam flows. The gap can be widened or narrowed as required.

As a general rule the customer is free to use any typical control valve which is approved for steam control.

Standard are the Spirax-Sarco Valves from HygroMatik. Alternative suppliers can be listed on application.

Control valves ARI type BR440

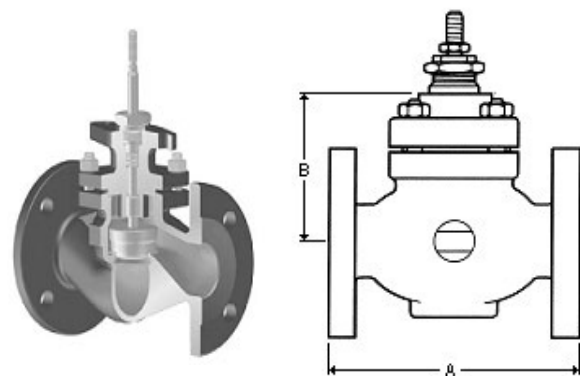
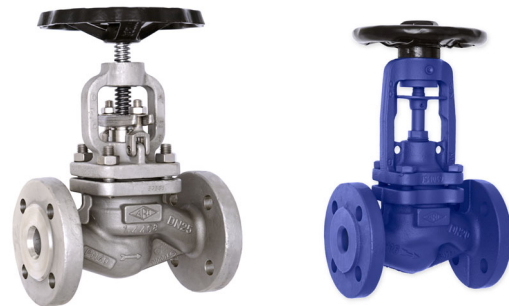

Flanged	A	B	Kvs-Value [m <sup>3</sup> /h]
DN15	130	118	0.25, 0.4, 0.63, 1.0, 1.6, 4.0
DN20	150	118	6.3
DN25	160	126	10.0
DN32	180	126	16.0
DN40	200	133	25.0

**Actuator**

The actuator controls the valve cone positioning against the valve face. Through continuous actuation a specific control signal can be assigned to every position of the valve cone.

To prevent air-duct over-saturation all actuators, even pneumatically operated ones, should be equipped with a fail-safe. This fail-safe closes the control valve immediately in the case of power failure or pressure loss.

Mögliche Regelsignale für Stellventil	
pneumatical	0,2 - 1,0 bar
electrical	3-Position 24V AC (230V on request)
electrical	0 (2) - 10 V, continuous Supply voltage 24V AC
electrical	0 (4) - 20 mA, continuous Supply voltage 24V AC The 500 Ohm (or 2x1K Ohm parallel) resistor is connected to over connectors 1 and 3. The resistor is attached under the cover.

**Electrical Actuator**

The spindle and valve cone are set in motion by the electrical actuator by means of a motor.

Electrical Actuators typically require a 24V AC/DC supply voltage and a control signal of 0-10 V.

Actuators with a 3 position control for modulated control voltages are also available.

In order to comply with DIN 32 730 an electrical actuator must have a fail-safe function so that in the case of a power failure the control valve is reset into a safe position (fully closed)



Typ Hygromatik B-4520005

Typ Spirax Sarco PN9000

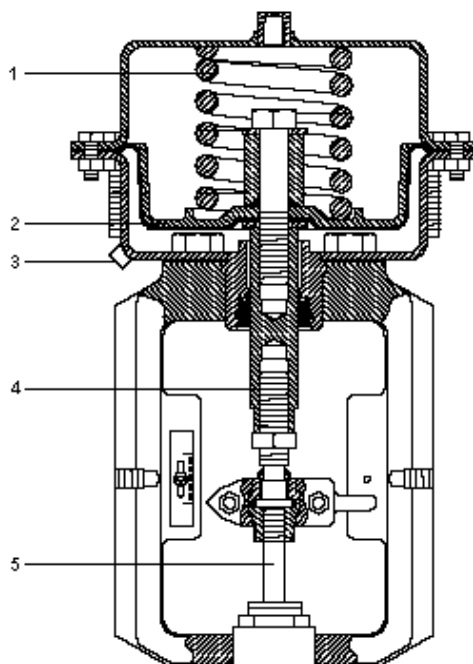

**Pneumatic Actuator**

Pneumatic Actuators are controlled using compressed air (e.g. 0,2-1barg).

Compressed air is supplied over a **compressed air supply (3)** to a **diaphragm (2)**. As soon as the supply pressure exceeds the **spring (1)** strength the diaphragm is pushed upwards. This pulls the two actuator **spindles (4)** and **control valve (5)** upwards and the actuator opens.

If control pressure drops the spring lowers the spindle again. In the case of a total pressure loss the spring immediately causes the control valve to close.

### 4.3.4 Start-up safety switch

The start-up safety switch ensures that no condensate from the steam network has entered the air conditioning duct over the steam lances.



electrical Start-up safety switch E-4111952

#### Electrical Start-up safety switch

With an electrical actuator the supply voltage is looped through the start-up safety switch. The start-up safety switch is set to allow the supply voltage through only when a specified temperature (in this case 80°C) is reached.

If the temperature remains below this level the fail-safe function is triggered.

#### Pneumatic Start-up safety switch

The pneumatic start-up safety switch keeps an exhaust valve open for compressed air as long as the specified temperature has not been reached.

This prevents control air from entering the actuator.

#### **NOTICE**

If no start-up safety switch is available it is advisable to let the unit run a few minutes before switching the control on. This allows time for the steam lance heating system to heat the lances.

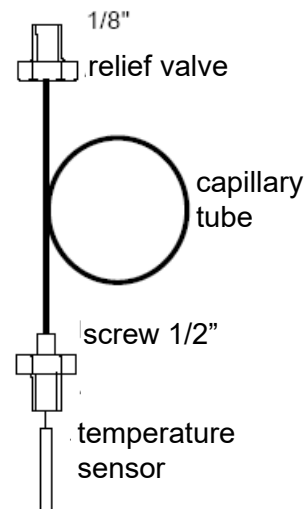

#### **Please note**

The wiring diagram for the electrical connection of the actuator and start-up safety switch can be found in the chapter Electrical connection.



### 4.3.5 Steam Lances

In the steam lances dry steam is blown out of specially formed nozzles. They are designed for low noise steam emission. The nozzles take steam from the driest area in the steam lance centre.

In order to prevent accumulated condensate or aerosol droplets from being transported with the steam, the steam lances are provided with a steam lance heating system. Due to this system such droplets either evaporate or cannot form in the first place.

The steam lance heating system can be fed by the separator or from a separate steam reservoir.

**NOTICE**

Steam pressures of 1 barg or higher have an optimum heating effect on the steam lances. With less pressure the pre-heating and re-evaporation times may be lengthened.

**Re-evaporation**

In some cases condensate remains in the steam lances immediately following control valve closure. This condensate is evaporated by the steam lance heating system and exits the steam lances as pressureless steam. Re-evaporation of residual condensate can take up to 20 minutes. The higher the steam pressure the better is the performance of the steam lance heating system and the shorter the evaporation time.

**Number of steam lances**

The steam lance system may comprise multiple steam lances.

With a duct height of more than 1000 mm multiple lances should be positioned horizontally one on top of the other. This ensures an even steam distribution. See table for number of steam lances recommended for various duct heights.

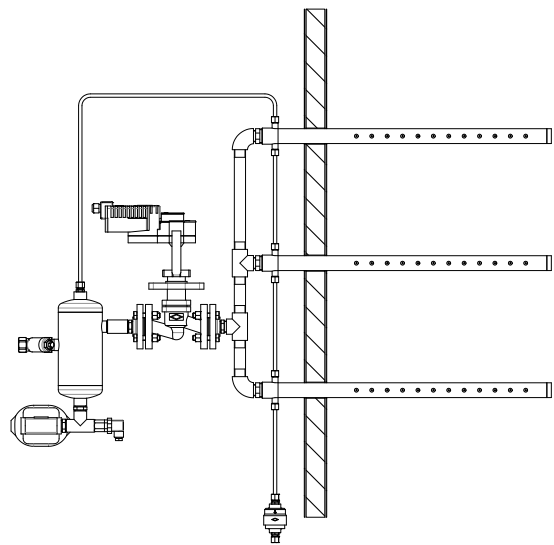

Duct height	Number of lances
up to 1000 mm	1
1000 - 1700 mm	2
1700 - 2200 mm	3
2200 - 2600 mm	4
over 2600 mm	5



**NOTICE**

Check number of steam lances when the following factors apply:

- duct air speed exceeds 5 m/s.
- Duct air temperature under 21°C.
- Last fine mesh filter located less than 3 m behind steam lance.
- Air flow branching occurs less than 1 m behind steam lance.

Depending upon additional parameters such as pre-defined steam output, existing or desired absorption distance or rise in humidity the installation of additional lances may improve efficiency.

---

**Steam lance piping for multiple steam lances.**

HygroMatik standard supply is for lengths of 300 mm and 450 mm. **Distances are approximate and can vary from installation to installation.** Piping should be installed for even lance distribution along the duct height. Distance between duct floor and ceiling should not exceed 250 mm.

---

**4.3.6 Pressure Gauge Station**

Installation of a pressure gauge on the steam injection unit ensures immediate detection of pressure drops or fluctuations.

The HygroMatik Pressure gauge station consists of a tubular spring pressure gauge (0-6 bar), a T-junction and a dual nipple.

The pressure gauge is temperature resistant up to 200° C.

Pressure gauge shut-off valves and siphons are available on request.

**NOTICE**

The pressure gauge station is to be installed upstream of the steam injection unit.

### 4.3.7 Ball Float Steam Trap

After separation from the steam inside the separator condensate is drained out through a ball float steam trap.

#### Function

The discharge valve is controlled by the ball float dependent upon the density of the incoming medium.

#### **Please note**

During installation, it is important to ensure that the marking "TOP" is in the correct installation direction. The sideway arrow shows the flow direction.

#### **NOTICE**

Water hammers can severely damage the ball float, condensate loads in outdoor installations increase the risk of freezing.

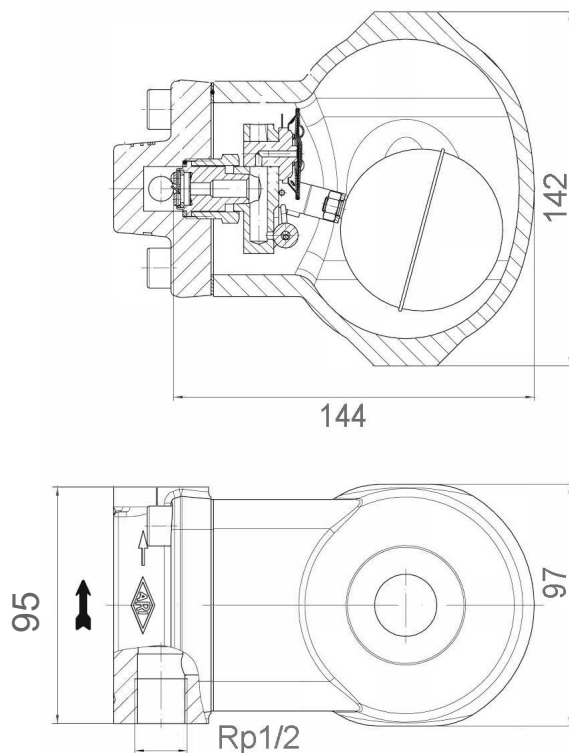

*sectional view Ball Float Steam Trap*

### 4.3.8 Thermostatic Capsule Steam

Condensate that has collected in the steam lance heating system is discharged through a thermostatic capsule steam trap.

#### Function

The discharge valve is controlled dependent upon the capsule volume and the temperature and pressure of the incoming medium.

The capsule contains a liquid whose saturation curve parallels that of steam. However, the liquid boiling point is always somewhat less than that of water.

#### Please note

During installation, it is important to ensure that the marking showing the correct installation direction is taken care of. The sideway arrow shows the flow direction.

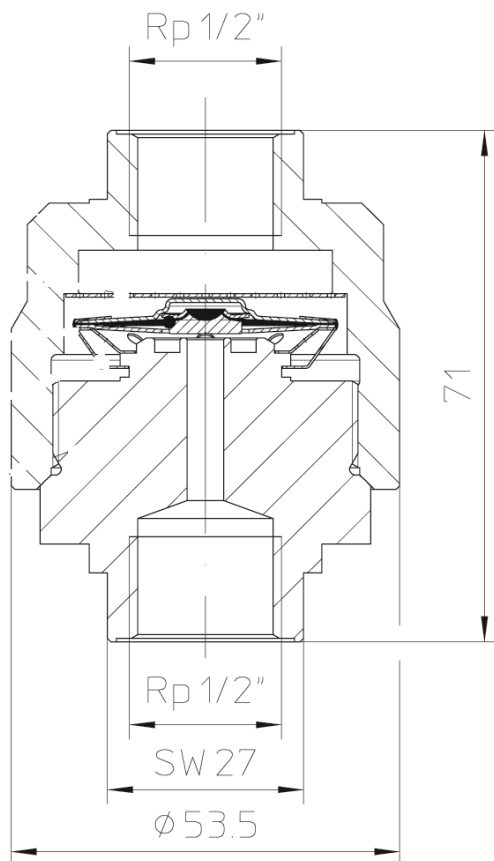

#### NOTICE

Do not insulate the thermic capsule steam trap.

The **minimum connection pipe length of 1.0 m (L3)** between the lance connection and the drain is absolutely mandatory.

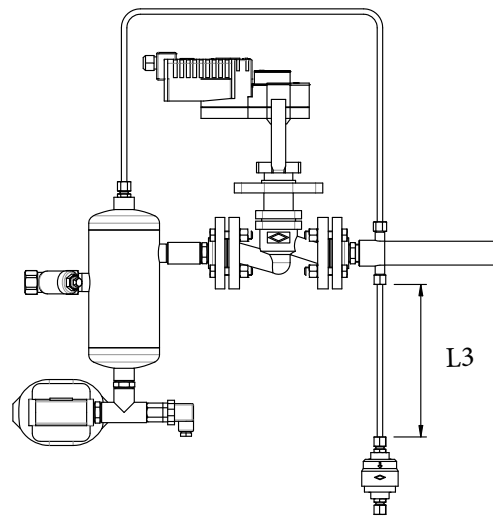

L3

## 5. Humidification Output

The maximum humidification output [kg/h] of one steam injection unit depends upon the available steam pressure in barg.

Maximum humidification output can be more than 770 kg/h (Type A) or 730 kg/h (Type C). Maximum operating pressure is  $p_{max} = 4,5$  barg.

### 5.1 Output Graphs

The following graphs serve as an aid to determining the necessary Kvs-Values for the control valve, a given steam pressure and a desired humidification output.

The graphs help to determine whether a Type 20 or Type 40 should be selected.

Type 20 up to approx. 270 kg/h.  
Type 40 up to approx. 770 kg/h.

### 5.2 Determining the control valve Kvs-Value

#### Control Valve $K_{vs}$ - Value:

The Kv-Value corresponds to a water flow rate (in  $m^3/h$ ) through a valve at a pressure difference of 1 barg and a water temperature of 5 - 30 °C.

A Kv-Value is valid only for the corresponding valve lift of a valve. The Kv-Value of a valve at nominal lift (100% open) is described as the Kvs-Wert. Using the Kvs-Value one can determine the maximum possible flow.

Separator Typ 20 for only one lance

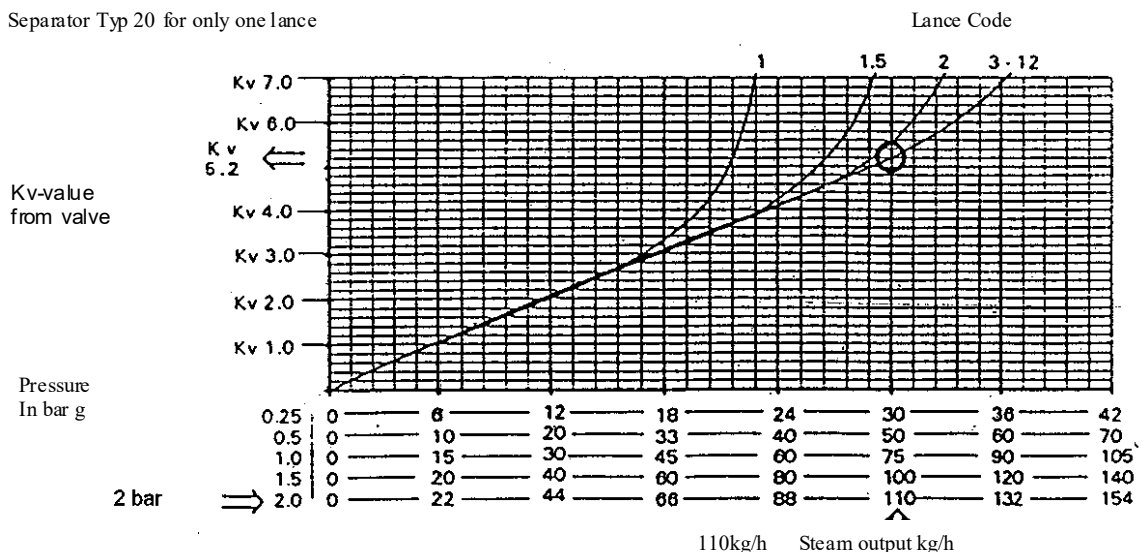

$K_v$	flow figure [ $m^3/h$ ]
$K_{vs}$	Valve coefficient [ $m^3/h$ ]

#### Example:

Desired humidification output: 110 kg/h

Operating pressure,  $p = 2$  barg

The length and number of steam lances is determined by the duct dimensions. See Section 9 "Steam Lances".

#### Result:

Follow the operating pressure line until the desired humidification output in kg/h is reached.

Run a vertical line upwards from this point until it intersects the plotted curve. The first intersected curve indicates the steam lance code and its minimum length.

Now run a horizontal line to the left and read off the minimum Kv-Wert of the installation on the vertical axis. The minimum Kvs-Value for selecting the control valve is  $K_v=5,2 m^3/h + 10\% = K_{vs}=5,7 m^3/h$ . If this value is not present in table 6.4 then it is recommended to take the next higher value..

If the customer has not specified something else, then it is always calculated whether the desired output can be achieved with the Type 20. In this case a Type 20 separator and a steam lance of at least code 3 is necessary. Always check whether this result is consistent with the results from Section 9 "Steam Lances."

### 5.3 Separator Type 20 with one steam lance

**Please note**

The following 4 graphs show Kvs -Values determination.

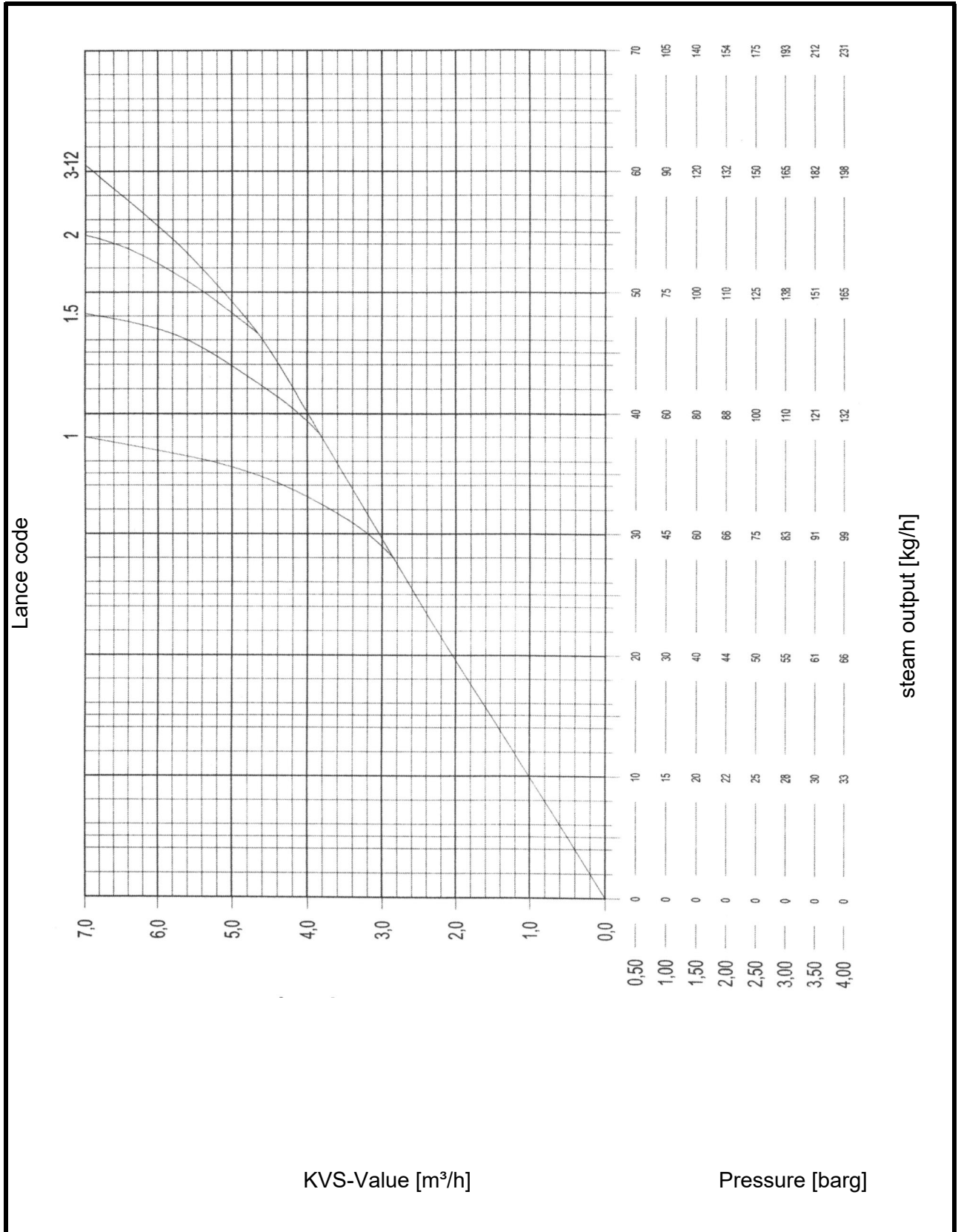



### 5.4 Separator Type 20 with multiple steam lances

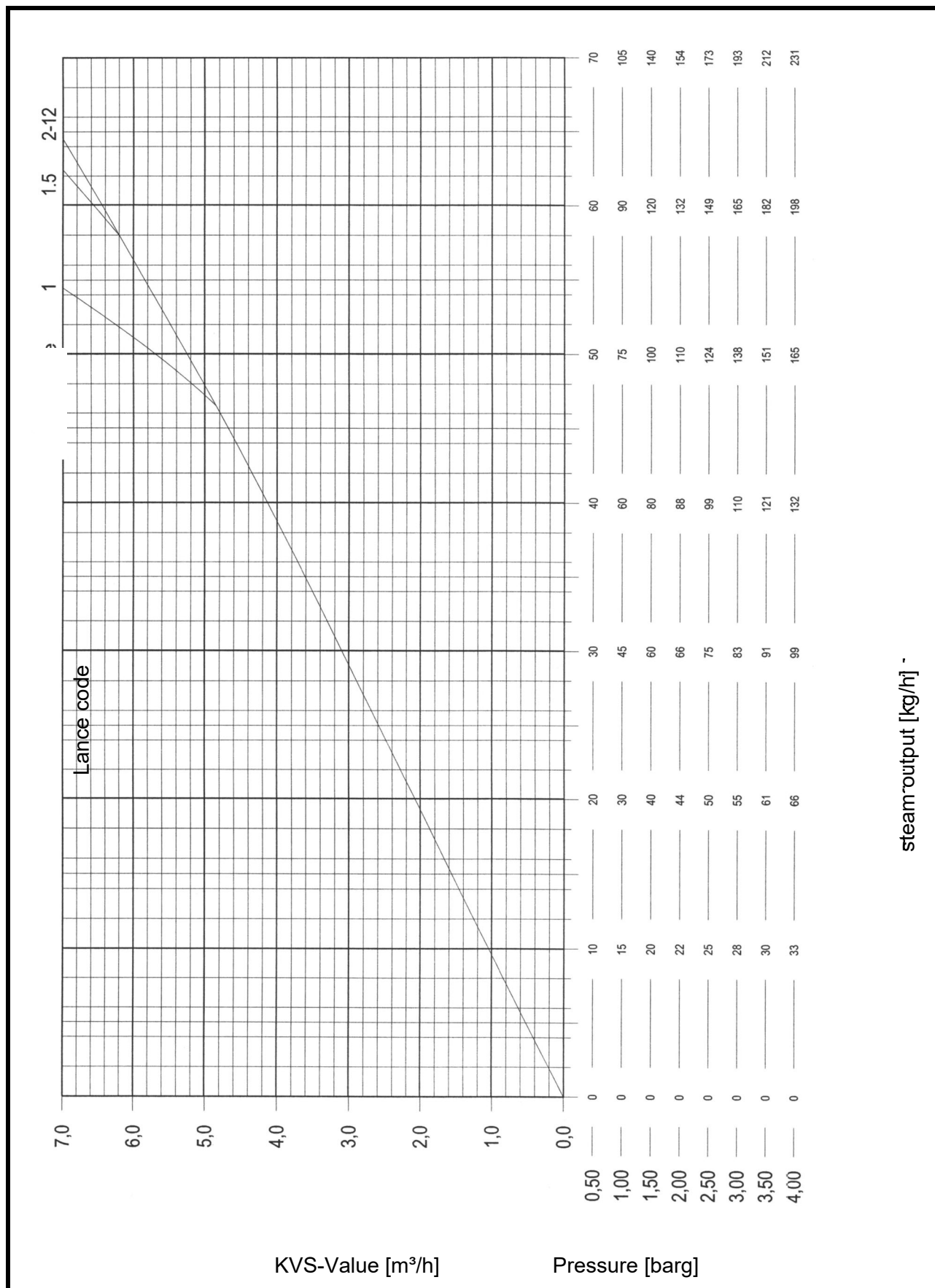

steam output [kg/h]

**5.5 Separator Type 40 with one steam lance**

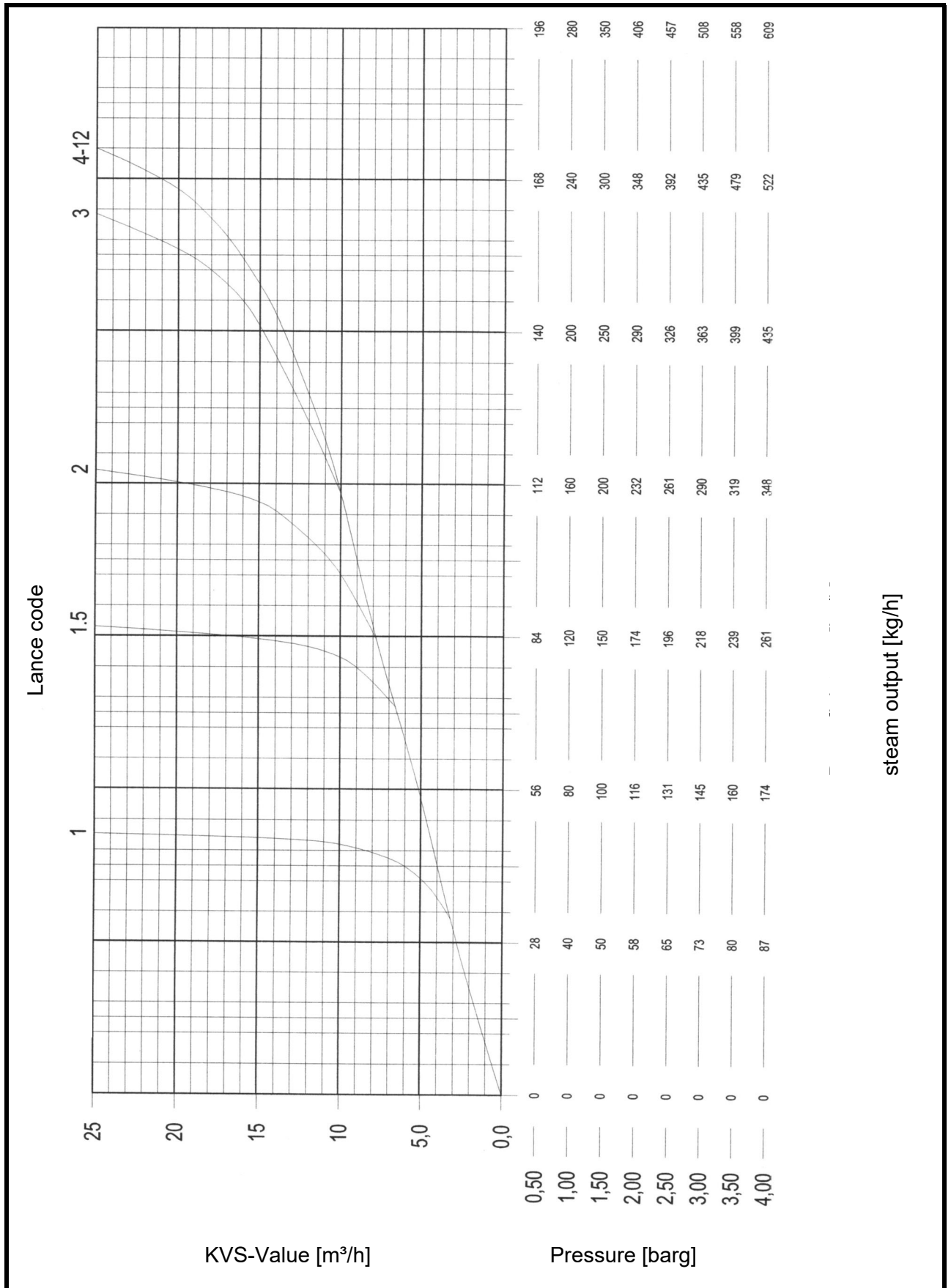



**5.6 Separator Type 40 with multiple steam lances**

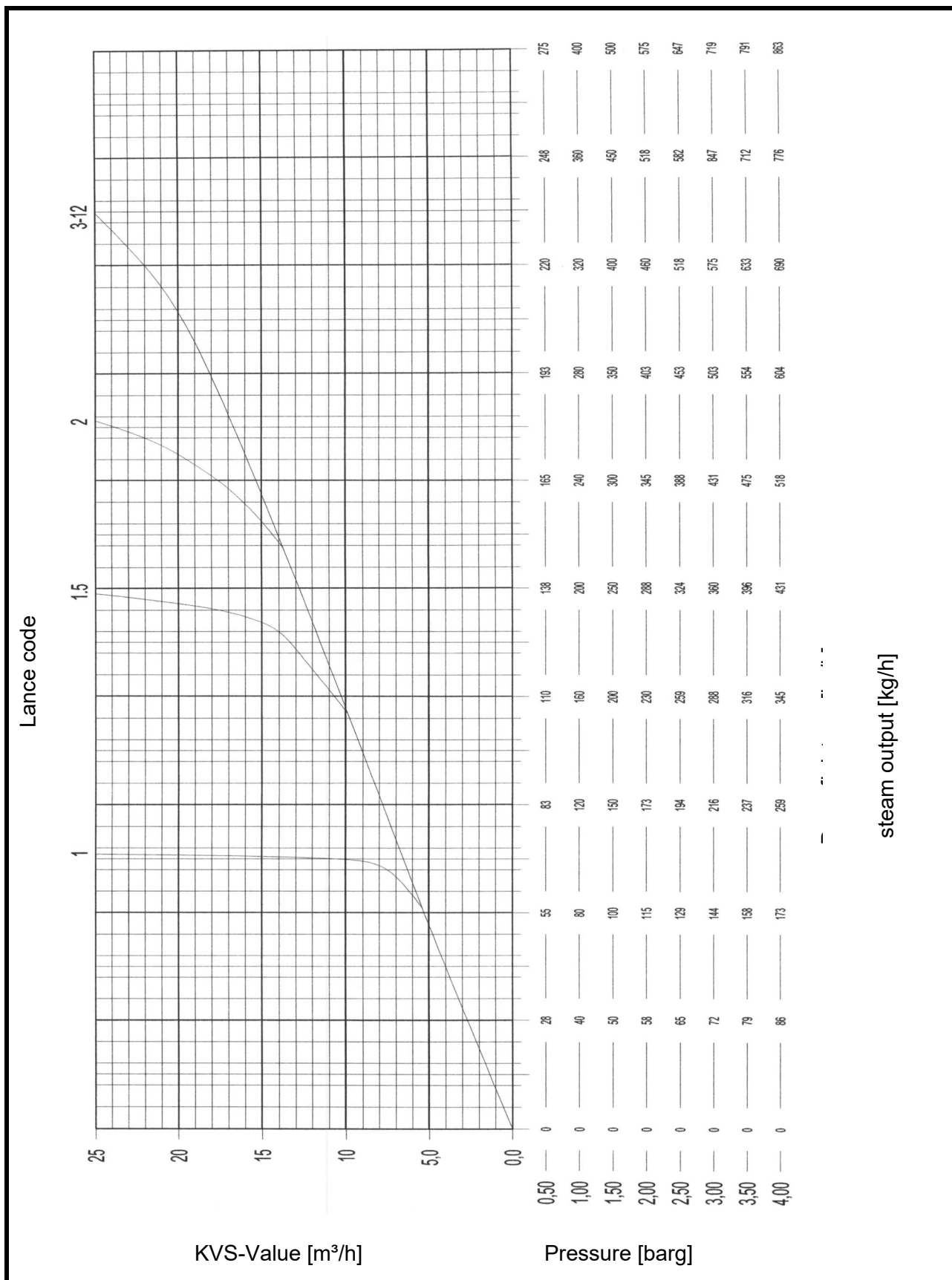

## 6. Graph for Determining Absorption Distance

### Absorption Distance: distance from the steam outlet until the end of the visible trail

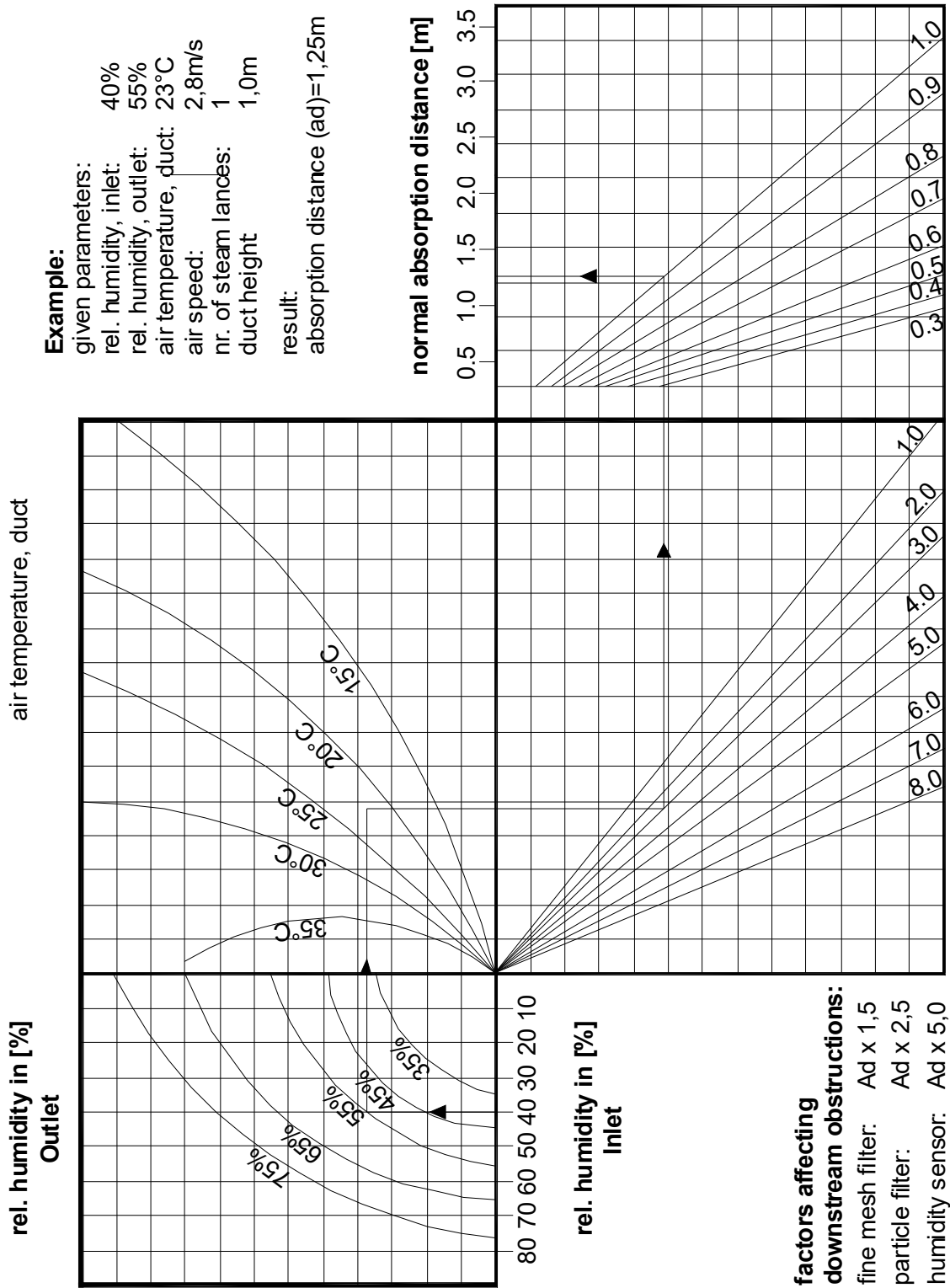

**Example:**  
 given parameters:  
 rel. humidity, inlet: 40%  
 rel. humidity, outlet: 55%  
 air temperature, duct: 23°C  
 air speed: 2,8m/s  
 nr. of steam lances: 1  
 duct height: 1,0m  
 result:  
 absorption distance (ad)=1,25m

**factors affecting downstream obstructions:**  
 fine mesh filter: Ad x 1,5  
 particle filter: Ad x 2,5  
 humidity sensor: Ad x 5,0

## 7. Mechanical installation

### **⚠ WARNING**

#### **Risk of foot injuries!**

Prevent unit from dropping during installation! Helping hand of a second person is advisable.

### **⚠ WARNING**

#### **Risk of electrical shock!**

Hazardous electrical voltage. During installation, the unit must be disconnected from power supply and secured against being switched on again. The absence of voltage must be ensured by a measurement.

### **NOTICE**

- This steam injection humidifier may only be installed by qualified personnel. HygroMatik can accept no responsibility for any damage caused by incorrect installation.
- Please observe all safety and hazard instructions supplied with the steam injection humidifier.
- Installation of any additional units is only permitted following written permission by the manufacturer, otherwise all guarantees are null and void.
- Individual packing should be opened at the installation site. This can prevent damage to individual items.

### **NOTICE**

HygroMatik steam injection humidifiers are delivered largely pre-assembled. If individual components are in the delivery then all installation instructions concerning those items are to be followed.

Normally the steam supply supports are sufficient to support the steam injection system. Should this not be the case then extra supports must be provided (for instance using a fixed and supported U profile arrangement).

### **NOTICE**

Steam lance fittings are not suitable to support the entire humidification unit.

Supports are to be done on-site.

### 7.1 Allowable environmental parameters

### **NOTICE**

When selecting the installation site for the steam humidifier, take the following into account:

- By design, HygroMatik steam humidifiers are not qualified for outdoor installation (electronical components and water-bearing parts may be damaged)
- Ambient temperature must lie between +5 and +40 °C (+41 and +104 °F)
- Relative humidity must not exceed 80 % r.h.

Installation in a closed room requires aeration and, eventually, temperature conditioning in order to meet the a.m. environmental conditions

### 7.2 Attaching steam pipes

### **⚠ WARNING**

When installing please observe the following:

- all work is to be done by qualified personnel only.
- Use only steam with no chemical additives.
- Use only dry saturated steam.

**NOTICE**

- follow local regulations.
- Use only steam with a minimum pressure of 0,5 barg and a maximum pressure of 4,5 barg.
- Dimension the on-site steam connections (insulated) so that a steam velocity of 25 m/s is not exceeded.

**NOTICE**

HygroMatik recommends the installation of a shut-off valve in front of the steam injection system in order to facilitate any necessary maintenance work.

**7.3 Installing the steam pipes**

Steam piping must be installed inclined (at least 2% in flow direction). They must be fitted using a suitable pitch and suitable materials. The piping holders must allow for lateral movement. In more lengthy installations expansion fittings must be used to avoid expansion stresses.

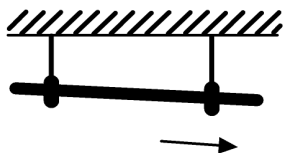

Steam connections must be fitted to the piping upper surface in order that condensate is not drawn into the piping system.

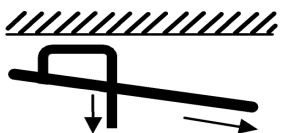

The steam outlet for the DDS must be in the direct neighbourhood (1-2m) of the steam connection.

The HygroMatik steam injection system must have a filter installed in front of the system. This is delivered with the system or is already installed on-site.

**NOTICE**

Ensure sufficient steam line drainage before and after the installed DDS.

**7.3.1 Water hammer prevention**

**▲ WARNING**

Water hammers are dangerous and can cause bodily harm.

It is necessary to drain off any low angles in order to ensure that condensate is not drawn along and to avoid water hammers. Very long steam piping systems must also be drained regularly.

**Water Hammers:** Condensate accumulates in depressions. During start-up, steam flows over the condensate causing it to vibrate. This can continue until a certain amount of condensate is carried off. At the next flow bifurcation this condensate hits the first available object at a velocity of up to 27 yd 1 ft/s (25 m/s). This impact is known as a water hammer.

**Condensate load:** Accumulated condensate which cannot drain due to a depression.

**NOTICE**

Steam piping must be installed using state-of-the-art methods.

Ensure professional installation and drainage of the steam lines by a certified specialist company.

This includes, among other things, the installation of condensate traps in accordance with valid guidelines.

Trap sets should be installed:

- before high points
- at low points
- before shut-off fittings
- before control valves
- in long pipelines every 30 - 50 m

Also install shut-off valves at the condensate traps for maintenance purposes.

## 7.4 Separator

### **NOTICE**

- Before installation, check out the steam supply piping. It must be established that the steam humidifier is supplied with as dry a steam as possible (steam with as little condensate as possible).
- Steam pressure at the separator entry point must not exceed 4,5 barg.
- Steam humidifier operating pressure must be kept at a constant level. It is possible that in order to generate constant pressure, pressure reduction stations may be required.
- It must be guaranteed the steam supplying the steam humidifier is as dry as possible. Check that the steam supply lines are equipped with the necessary condensate drains.
- The supply line for the steam humidifier must be taken from the highest point in the main supply line.
- Install a filter in the steam supply line directly in front of every humidifier. This is the only way to ensure that no foreign objects can find their way into the humidification unit.
- Keep the piping connections as short as possible. In this way the energy losses are reduced, the system can heat up quicker, condensates are minimised and the system overall efficiency is increased.

## 7.5 Control Valve and Actuator

If the valve is part of the on-site installation, the necessary connection fittings between control valve and the separator come attached to the separator. All other parts are delivered separately (e.g. connection bolts and flange seals).

Only control valves suitable and certified for steam regulation may be used.

Actuators must have a fail-safe function in order to prevent an uncontrolled over-humidification in the case of a power failure.

Dirt between the valve face and cone prevent proper closing. Therefore install a filter directly in front of the separator.

### **NOTICE**

- Control air for pneumatic actuators must be free from oil and humidity.
- If control valves and actuators are part of the delivery then operating and installation instructions are present.
- Customer is responsible for checking steam injection humidifier compatibility if control units from other manufacturers are used.

Actuator and valve installation positioning:

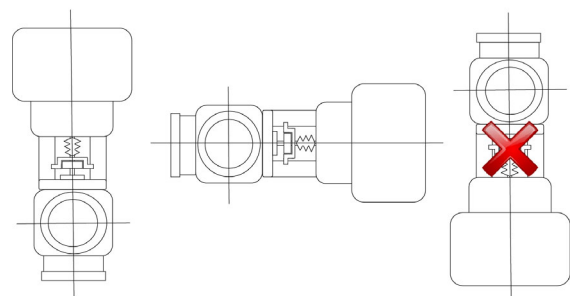

## 7.6 Pneumatic Start-up safety feature

### **NOTICE**

Pneumatic start-up safety is set at 96°C. This value can be altered only by the manufacturer.

- » First install a T-piece with a 1/2" exit in the condensate piping in front of the condensate drain.
- » A T-piece with a 1/8" exit is also installed in the control air piping.
- » A temperature sensor is screwed into the T-piece in the condensate piping.
- » The 1/8" drain valve is installed in the air control piping in the T-piece.
- » Take great care not to damage the capillary by bending.

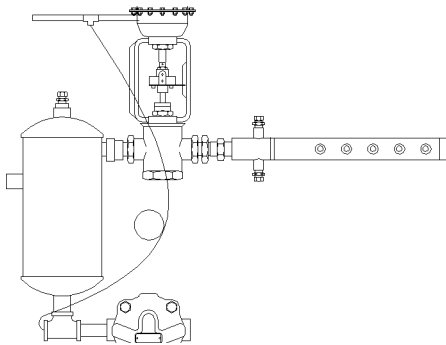

## 7.7 Steam Lances

With single lance systems the lance is fitted directly onto the valve exit using the delivered fittings.

If multiple lances are necessary to distribute steam in the ducting, then there is a complete assembled steam lance piping in the delivery. Angle pieces for installation of humidifier/valve unit parallel to ducting walls are available from HygroMatik.

**In order to reduce the absorption distance the steam from the lance should be directed opposed to the air direction in the ducting.**

All piping seals should be done with temperature resistant (>150°C) sealing tape.

If only one lance is required for even steam distribution install this at duct half-height.

With a multiple lance system position the lances so that there is an even steam distribution over the duct cross section and ensuring that the necessary duct wall distance is guaranteed.

HygroMatik can supply stainless steel standard modules for lance pitches of 300 and 450 mm

**The distance between lance and duct ceiling or floor should be a minimum of 200 mm.**

Before the lance is installed in the duct check that the correct lance is present. The steam lance should be utilized over the entire duct width (Please observe the lance codes). Steam lances are pressed into the appropriate holes.

**Steam lance nozzles should be positioned opposed to the air flow.**

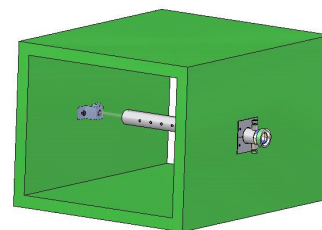

In order to prevent steam condensing on the duct inner walls the lances should be installed according to the following dimensions:

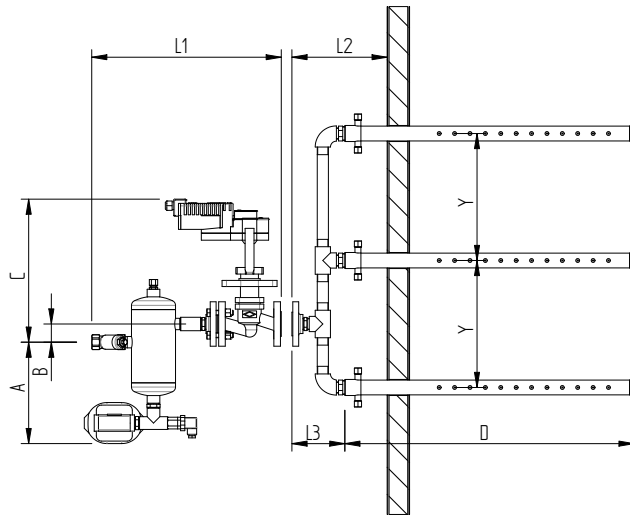

	DDS20 A [mm]	DDS40 A [mm]	DDS20 C [mm]	DDS40 C [mm]
L1	310...330	440...500	420...440	660...700
L2 one lance system	170	200	170	200
L2 multiple lance system	250	300	250	300
L3 one lance system	70	100	70	100
L3 multiple lance system	150	200	150	200
A	310	330	260	350
B	/	/	43	70
C	310	330	330	360
Y*	300 / 450			
D	see technical data lance			

Distance lance/duct wall: 100 mm (L2-L3)

\* other distances possible on demand

**NOTICE**

- At 0.5 barg to 2.0 barg steam pressure there is a minimum distance of 200 to 300 mm to existing elements which must be kept to. Higher pressures and/or sensitive elements need 500 mm.
- A duct wall thickness of 30mm is assumed. If „m“ is larger than 30mm, then the distance „q“, is to be reduced by the difference **m-30mm**.

**7.7.1 Duct mounting set for steam lance**

After the lance is positioned, an angle is positioned on the opposite duct wall side at the same height. The screws are self tapping. Then the necessary threaded bar length „y“ is measured.

$$y = z + 20\text{mm}$$

**NOTICE**

- A gap x“ between bar end and duct inner wall must be present in order to accomodate a lance lateral expansion.
- Steam lances from code 2 on must be supported at the end.

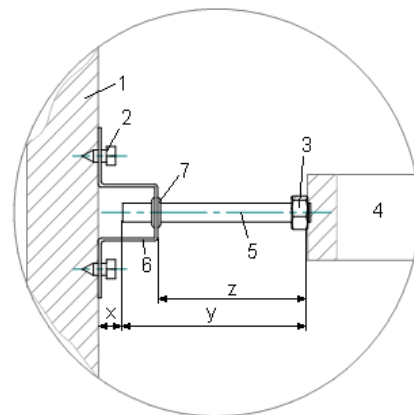

Number	Description
1	Duct wall
2	Screw M6x35
3	Nut M10
4	Steam Lance
5	Threaded bar M10 & M8 x 250
6	Angle
7	anti-vibration collar

The diameter of the hole in the duct wall is:  
SIH 20: 38 mm /SIH 40: 54 mm



**Lance guide is installed in the following manner:**

- » feed bar through hole in angle
- » screw M10 bar end in the steam lance
- » use nut to lock to lance

Alternatively, the lance can be installed from the duct ceiling with a threaded bar or held in a U pipe. The necessary parts thereto are to be supplied on site.

After the lance has been installed the gap between duct outer wall and lance is closed using the two cover plates as supplied with the steam lances. The cover plates are attached using two self tapping panel screws. The sealing between cover and duct wall should be done with silicone or a rubber sealant.

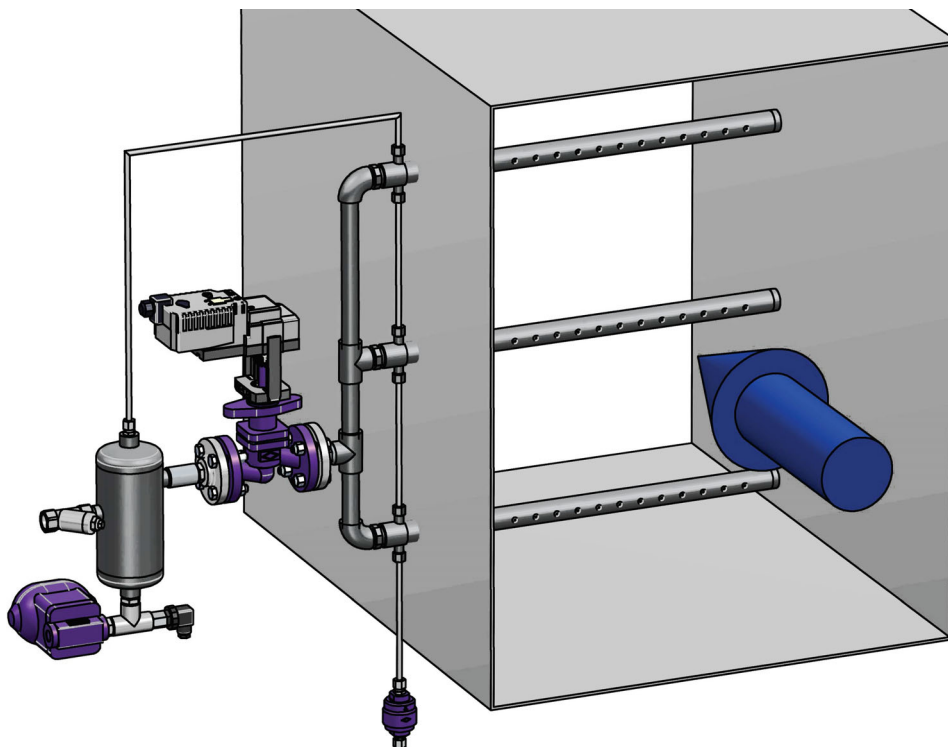
**7.7.2 Installation Examples****NOTICE**

If lances are positioned vertically then the steam supply piping should have an additional float controlled condensate drain.



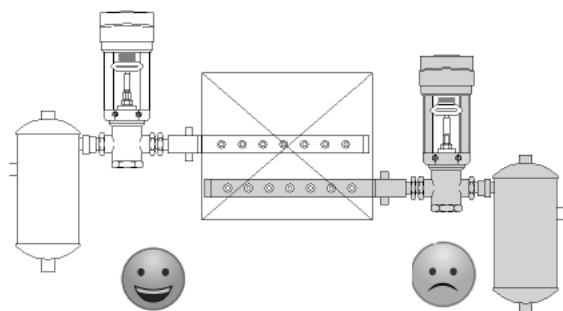

Position lances in the duct centre if possible.

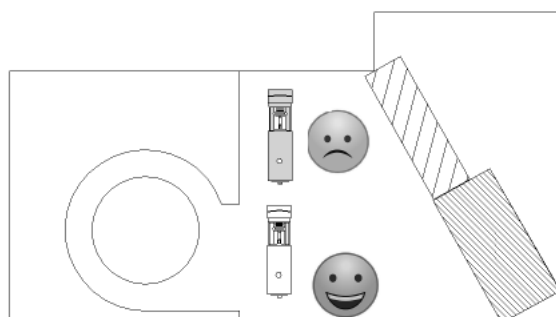

If the humidifier blows into a compact multi-zone unit then it should be installed directly in the air flow and as close as possible to the fan.

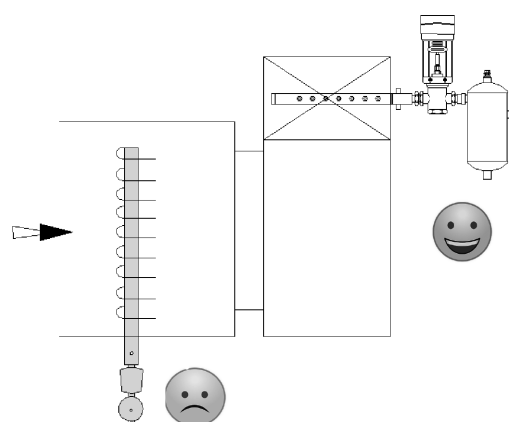

The bifurcated pipe should never be installed less than one meter in front of the fan suction side. In this case the correct installation is behind the fan.

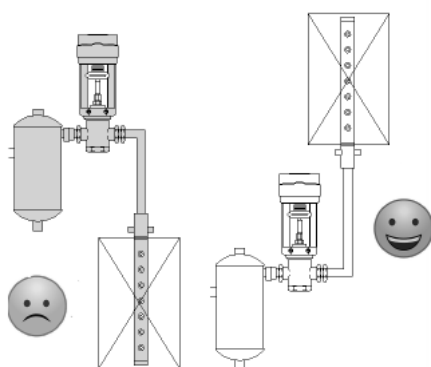

Never install the lances pointing vertically downwards. This would cause condensate to collect in the steam lance heating system. On the other hand a vertical installation pointing upwards is possible.

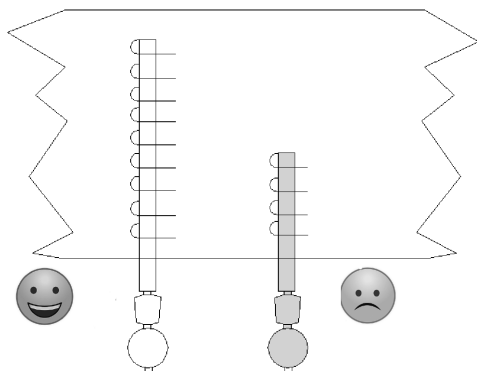

When selecting the lance choose a size sufficient for the entire duct width or height.

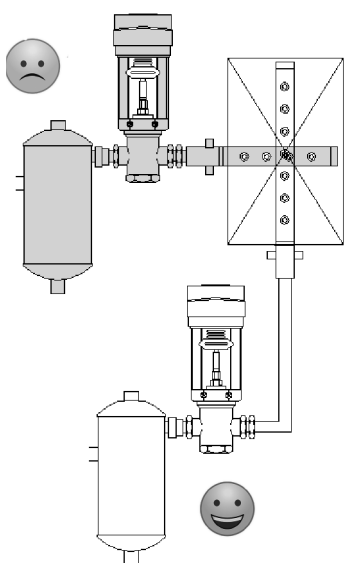

If the ducting is taller than it is wide, install the steam lance vertically. If this is not possible then a second lance must be installed in order to ensure an even steam distribution.

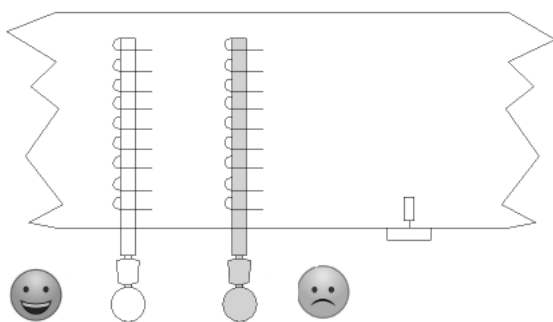

Lances should have a minimum distance of 5x the absorption distance to the duct humidity controller.

## 7.8 Steam Lance Heating System

### **⚠ WARNING**

The line to the heating system must be able to tolerate pressures of up to maximum 8 barg.

### **NOTICE**

- The pipe is easy to bend with a suitable tool. The customer must adjust the pipe in accordance the conditions on site. Take care not to kink the pipe when bending.
- Observe minimum bend radius of 1,5 x diameter (here: 1,5 x 8mm= 12mm)
- Alternatively it is possible to close off the connection to the separator and feed the steam lance heating system from another separate steam reservoir with a maximum pressure of 4,5 barg. Higher steam lance heating temperatures result from higher pressure and cause an even better heating effect.

Installation of the steam lance heating system follows the installation of the steam injection system including steam lances. In accordance with the dimensions of the humidifier unit a pipe with an external dimension of 8mm is bent to shape and installed with the help of the supplied pipe fittings (1/4" Cutting ring screw connection).

Pipe length „L4“ must be at least **1 meter** to ensure effective functioning of the capsule condensate drain. There are various installation possibilities, also where there is little room. Important here is to ensure the optimum vertical positioning of the capsule condensate drain. Pressure in the condensate piping must not exceed half the pressure in the heating piping.

**Piping must always be installed properly inclined.**

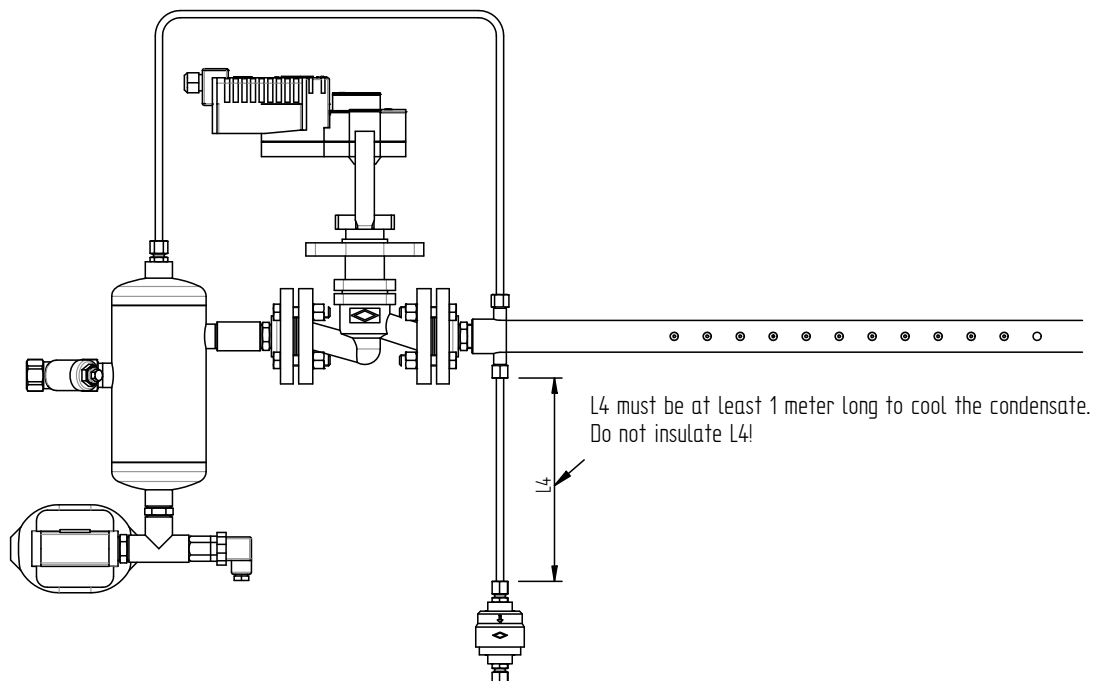

## 7.9 Check List

### **NOTICE**

The steam injection humidifier may only be operated by qualified and authorised personnel.

Before switching on the steam injection humidifier please check for correct installation by going through the following check list:

- Have the steam supply lines been flushed out?
- Are the steam supply and condensate lines properly connected and secure?
- Is a condensate trap installed directly before the DDS?
- Has the entire steam supply line up to the control valve been checked for leaks?
- Is the specified system pressure present?
- Is there a proper filter fitted before the separator? (normally part of the system delivery)
- Is the operating pressure at least 0,5 barg and maximum 4,5 barg?

Electrical installation checks must be carried out in accordance with customer requirements and public power utility regulations. All electrical connections must be according to the circuit wiring diagrams.

---

## 8. Electrical connection

### **⚠ WARNING**

All work relating to the electrical installation may only be carried out by designated specialist personnel (electrician or qualified person with equivalent training).

Do not connect the steam humidifier to the live power supply before all installation work has been completed.

---

### **Please note**

The customer is responsible for monitoring the qualifications of the specialist personnel.

---

### **General installation rules**

- All local rules concerning the implementation of electrical installations must be obeyed
- Electric connector cables to be laid professionally
- Install the electrical connections according to the wiring diagram

### **NOTICE**

#### **Possible electronical components destruction through electrostatical discharge!**

Prior to commencing electrical installation work, steps must be taken to guard the sensitive electronical components of the unit control against damage from electrostatical discharge.

---

### **Please note**

- If control units from other manufacturers are used, the customer must ensure compatibility with the pressurized steam humidifier.
- A humidity control unit should be provided for the operation of the humidifier, which must be installed according to the manufacturer's instructions.
- We recommend that you integrate a Max hygostat into the safety chain. The Max hygostat serves as a safety element in the event of a malfunction of the humidity sensor. Install the hygostat approx. 5 times the calculated absorption distance behind the entry point of the lances in the duct.
- Install a pressure monitor in the duct and integrate it into the safety chain. The pressure monitor prevents over-humidification of the duct in the event of fan failure.

**Wiring diagram for HygroMatik actuator**

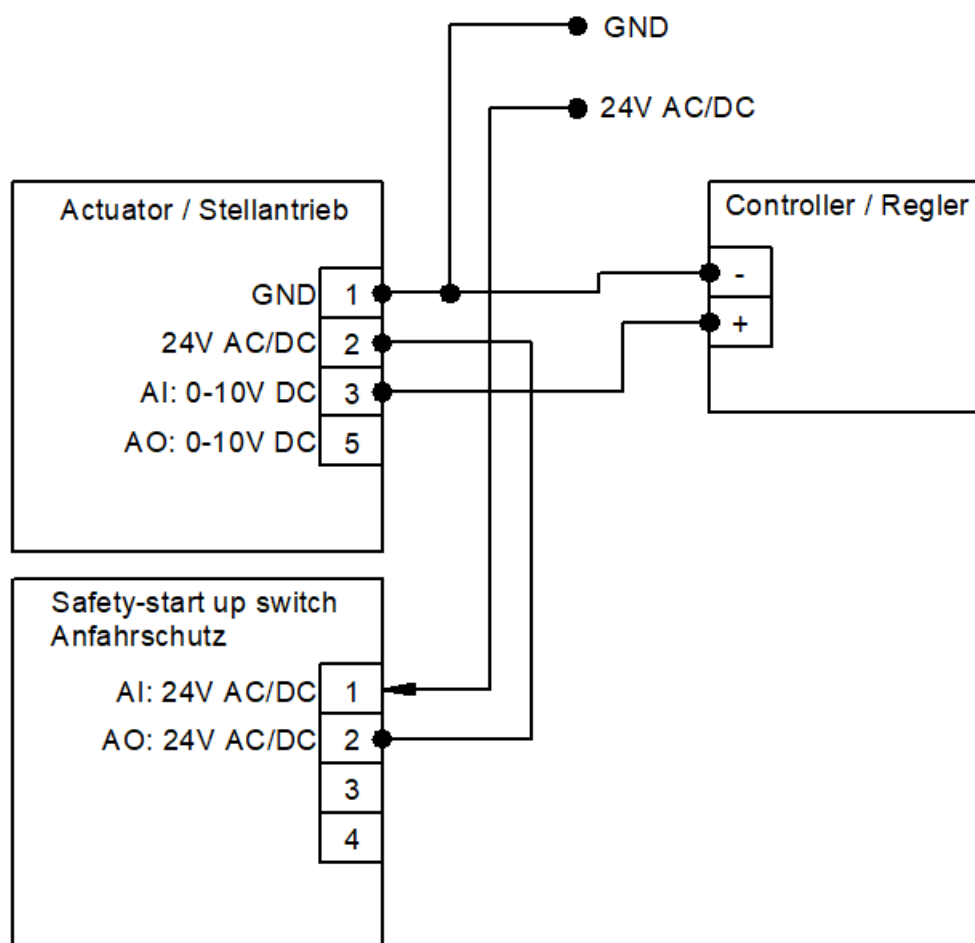

The wiring diagrams for alternative actuators can be found in the corresponding installation documents!

## 9. Commissioning

### **Risk of operating error!**

Start-up of the unit is restricted to expert staff only.

For actuator initial operation please refer to the instructions of the regulator ans/or installations company. Initial operation should only be done by a trained expert or service technician.

Follow the instructions below to ensure correct operation of your steam injection humidifier.

### **NOTICE**

During most installations dirt will have managed to enter the steam supply. Therefore it is advisable to flush out the piping before initial operation.

### **Turning off the steam injection humidifier**

Before starting up the steam injection humidifier it is essential to know how to switch it off.

- » Close shut-off valve on the steam supply to the separator .
  - » If applicable, also close the shut-off valve to the separate steam supply to the steam lance heating heating system.
- 

### **Turning the steam injection humidifier on**

### **NOTICE**

If the actuator is not a controlled actuator then verify that the control valve is in the closed position.

- » Slowly open the separator shut-off valve and, if there is one present, the shut-off valve to the steam lance heating system.
  - » Check the entire steam supply up to the control valve for leaks.
  - » Repair leaks as necessary.
  - » Check specified system pressure using the pressure gauge.
  - » Wait 10 - 15 minutes so that the steam injection humidifier can warm up. The pipes between the separator and the steam trap should be about the same temperature.
  - » Set the Max. Hygostat to the desired value.
  - » Set the humidity sensor to the desired value and activate the actuator.
-

**NOTICE**

Periodic filter cleaning is recommended in order to prevent the control valve from excessive wear. Before cleaning the filter always shut off the steam supply and allow the system to cool down.

**The following operations are active:**

- Accumulated condensate in the steam supply is forced into the separator where it is fed into the condensate network via the ball float steam trap.
- Some of the dry steam in the top part of the separator supplies the steam lance heating system and heats the steam lances.
- As soon as the actuator indicates that steam is required the control valve opens and sends steam into the steam lances.

**NOTICE**

For units with a start-up safety switch the control valve is released only when the piping between separator and ball float steam trap has reached its designated temperature.

**Risk of electrical shock!**

Hazardous electrical voltage!  
Follow safety instructions for work on live components.

---



## 10. Maintenance

The HygroMatik steam injection humidifier is easy to maintain. However, inadequate or improper maintenance can lead to operational malfunctions. Regular maintenance is essential so that your steam injection humidifier achieves a long, trouble free life span.

### **▲ WARNING**

#### **Risk of scalding.**

Before starting any maintenance work, make sure that the feed and drain are shut off and that the unit is depressurized and cooled down.

### **▲ WARNING**

#### **Risk of scalding.**

In case of leakage, uncontrolled steam can cause serious injuries. Shut off the steam supply and let the device cool down. Eliminate damage immediately.

#### **Caution: When performing maintenance work please note:**

- The steam injection humidifier is only to be serviced by qualified and authorised personnel.
- Follow safety instructions.
- Switch off the humidifier and protect against re-start. Allow the humidifier to cool down.
- After performing maintenance work have the steam injection humidifier checked for safe operation by qualified personnel.

The steam injection humidifier's performance and maintenance intervals depend primarily upon the steam quality and the humidification volume since the last maintenance. Different steam quality can shorten or lengthen maintenance intervals.

Recommendations on maintenance intervals are based exclusively upon typical, empirically established values.

## 10.1 Strainer

### **Maintenance „SIH Type A“**

- » Loosen the screws (M12/M16) on the flange connection (D) at the steam entry point. **Warning:** steam supply and SIHsystem should be fixed according to the assembly instructions
- » Steam supply pipes should be pulled free of the entry flange if possible.
- » If there is not enough room to exchange the filter then de-install the separator.
- » Exchange filter (C) and seal (B).
- » Re-connect the flange with seal to the steam entry point.
- » Check the flange for leakage after re-starting the system.



**Maintenance „SIH Type C“**

- » Unscrew filter holder (C) , (SW27 or SW50).
- » Extract filter (B) and clean or replace.
- » Replace seal (A).
- » Re-position filter.
- » Screw filter holder in.
- » Check for leakage by re-start

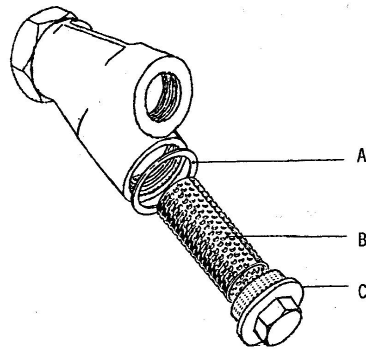

**Ball float condensate drain**

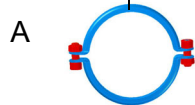
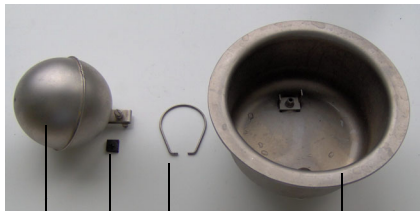

**10.2 Ball float condensate drain**

**Maintenance „SIH Type A“**

- » Release condensate drain from separator.
- » Loosen both Allen screws (size 6/8) of the lower separator screw clamp and remove clamp (A).
- » Release lower separator part (B)
- » Remove C clamp (C).
- » Release cone (D) with seal (E)
- » Loosen seal screw and replace seal if necessary
- » Tighten seal screw a little and lock down with nut without damaging the seal.
- » Re-fit cone and seal and fix at the separator base using C clamp.
- » Position new flange seal (F) at the bottom and fix with screw clamp to the separator.
- » Screw down both Allen screws simultaneously.
- » Check for leakages by re-start.

**Maintenance „SIH C“**

The float steam trap SIH C is designed to be maintenance-free. In case of malfunction, replace it completely.

**10.3 Thermostatic Capsule Steam trap Type MST21**

The Thermostatic Capsule Steam trap SIH C is designed to be maintenance-free. In case of malfunction, replace it completely.

## 11. Malfunctions

Problem	Possible Cause	to do
No steam is coming out of steam lance	<ul style="list-style-type: none"> <li>• Defective Hygrostat or humidity sensor</li> <li>• Defective Control Valve</li> <li>• Defective Actuator</li> <li>• Inaccurate or defective control</li> <li>• Fouled or blocked coarse strainer in the filter before separator</li> <li>• Shut-off valve in steam supply line is closed.</li> <li>• Pressure reduction valve, if installed, is out of order.</li> </ul>	<ul style="list-style-type: none"> <li>• Check Hygrostaten and/or humidity sensor and repair or replace as necessary.</li> <li>• Check valve and clean it or replace as necessary.</li> <li>• Measure control signal. Check, repair or replace as necessary.</li> <li>• Check actuator, reset, repair or replace.</li> <li>• Remove coarse strainer and clean or replace.</li> <li>• Open shut-off valve</li> <li>• Clean pressure reduction valve, possibly reset operational pressure.</li> </ul>
Steam is coming out of steam lance although desired humidity value is reached.	<ul style="list-style-type: none"> <li>• Foreign objects between valve cone and face prevent valve from closing properly.</li> <li>• Defective or falsely set Hygrostat or humidity sensor.</li> <li>• Actuator does not close properly.</li> <li>• Residual condensate evaporates in the steam lance and exits the lance as pressure-less steam (re-evaporation effect) This process can take up to 20 minutes.</li> </ul>	<ul style="list-style-type: none"> <li>• Check and clean valve valve.</li> <li>• Check humidity or Hygrostat and re-set or repair.</li> <li>• Re-adjust actuator to control valve.</li> <li>• Check out steam supply pressure for the steam lance heating system. Supply steam lance heating system from a separate dry steam steam reservoir (max. 4,5 barg).</li> </ul>
Condensate is coming out of steam lance	<ul style="list-style-type: none"> <li>• Insufficient installation of the steam supply line to the humidifier.</li> <li>• Defective or dirty steam trap on the steam dryer or steam lance heating system.</li> <li>• The back pressure from the condensate network is higher than the operating pressure of the pressurised steam humidifier.</li> </ul>	<ul style="list-style-type: none"> <li>• Check Installation.</li> <li>• Clean or replace steam trap.</li> <li>• Reduce pressure in the condensate return line.</li> <li>• If this is not possible, connect steam trap to separate return line.</li> </ul>

Problem	Possible Cause	to do
<p>Condensate is coming out of steam lance.</p>	<ul style="list-style-type: none"> <li>• Steam trap drain is considerably higher than the SIH system.</li> <li>• Start-up safety feature does not work properly.</li> <li>• Defective or unsuitable thermostatic capsule condensate drain attached to steam lance heating system.</li> <li>• Steam heating for steam lance heating system insufficient.</li> </ul>	<ul style="list-style-type: none"> <li>• Install condensate drain beneath the humidifier level and pump out the resultant condensate to a suitable place.</li> <li>• Check wiring and function of start-up safety feature.</li> <li>• Check out condensate drain and integrated elements. Type E must be used. Clean condensate drain.</li> <li>• Optimum heating effect occurs from pressure over 1 bar. Less pressure can lead to lengthier pre-heating times.</li> </ul>

**⚠ CAUTION**

**Risk of injuries!**

Switch off unit immediately in case of a malfunction being detected. Malfunctions may only be repaired by qualified personnel under observation of all safety instructions

## 12. Dimensions and Installation Schematic

Steam Injection System Type A (stainless steel)

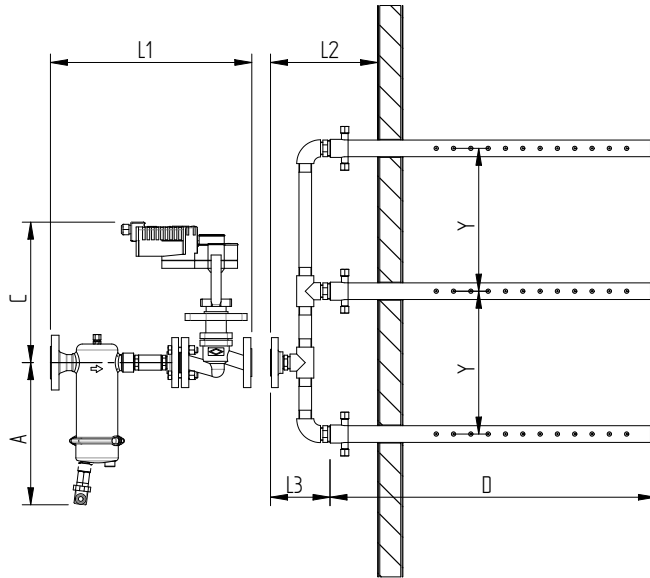

Steam Injection System Type C (mixed materials)

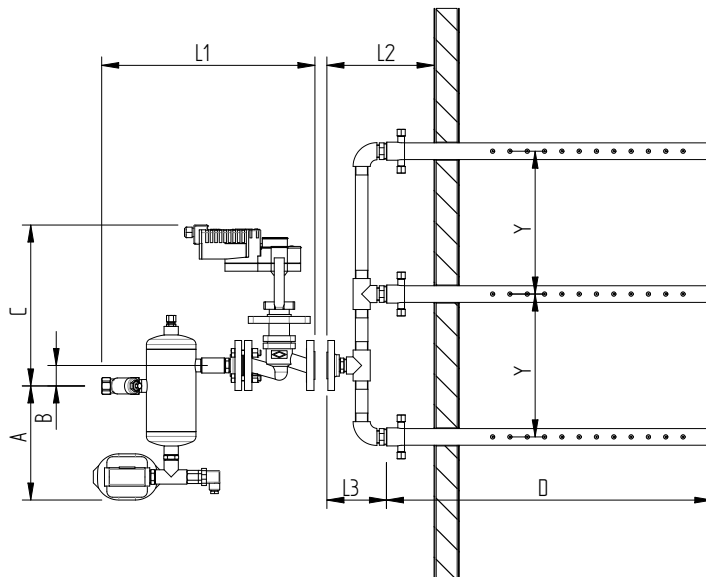

	DDS20 A [mm]	DDS40 A [mm]	DDS20 C [mm]	DDS40 C [mm]
<b>L1</b>	310...330	440...500	420...440	660...700
<b>L2</b> one lance system	170	200	170	200
<b>L2</b> multiple lance system	250	300	250	300
<b>L3</b> one lance system	70	100	70	100
<b>L3</b> multiple lance system	150	200	150	200
<b>A</b>	310	330	260	350
<b>B</b>	/	/	43	70
<b>C</b>	310	330	330	360
<b>Y*</b>	300 / 450			
<b>D</b>	see technical data lance			

Distance lance/duct wall: 100 mm (L2-L3)

\* other distances possible on demand

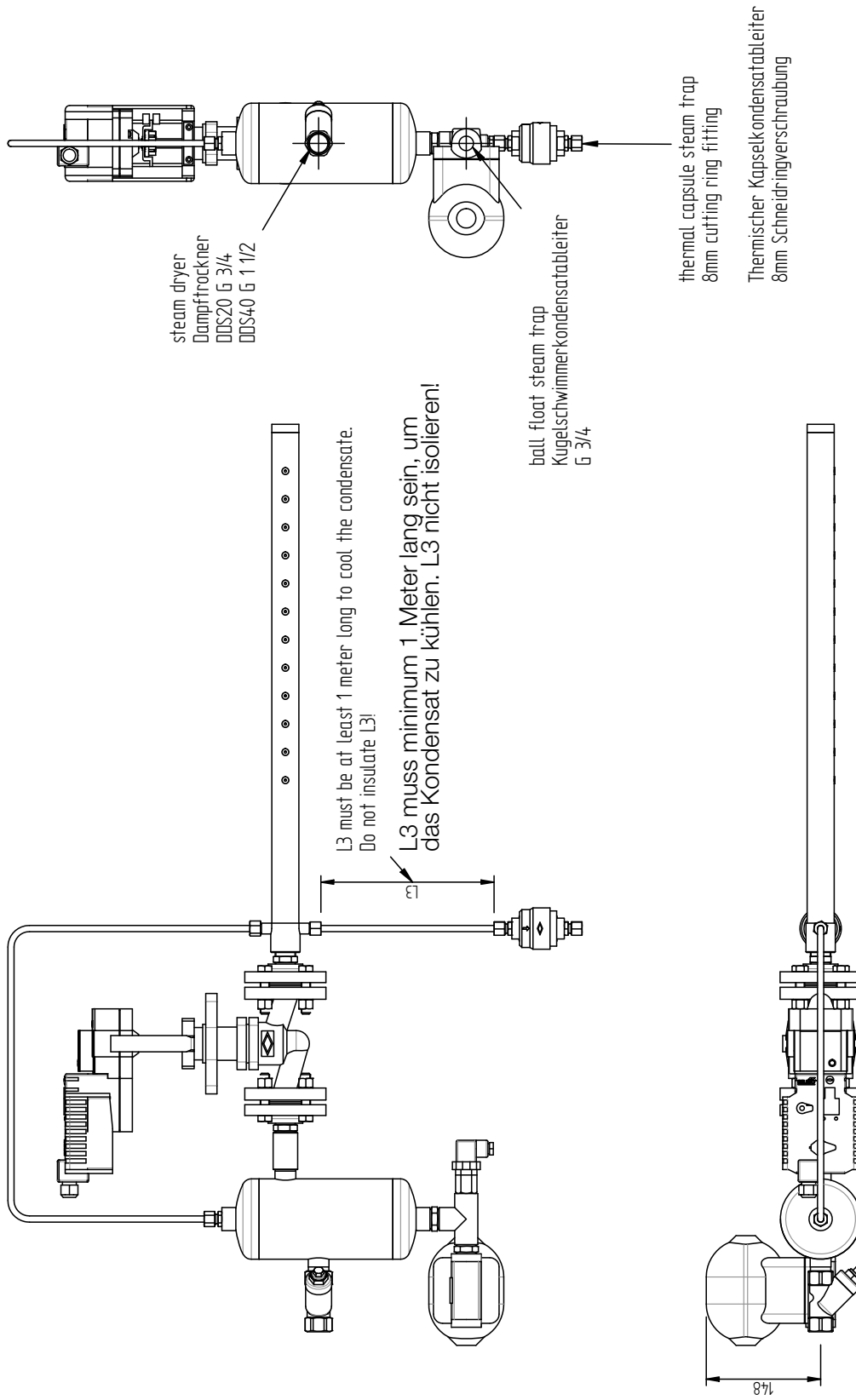

### 13. Spare Parts

Type A		Type C		Article Number	Description
Model	Model	Model	Model		
20	40	20	40		
		X		E-4111252	<b>Separators</b> Separator, without additions
			X	E-4111254	Separator, without additions
X				B-4500001	Separator DDS20 incl. ball float steam trap and dirt trap
	X			B-4500003	Separator DDS40 incl. ball float steam trap and dirt trap
X				B-4111917	maintenance set DDS20 Version A (encloses: seals, dirt trap)
	X			B-4111919	maintenance set DDS40 Version A (encloses: seals, dirt trap)
					<b>Dirt trap</b>
X		X		E-4112202	dirt trap type 316 connection 3/4", stainless steel
	X		X	E-4112204	dirt trap type 316 connection 1 1/2", stainless steel
					<b>Steam trap</b>
X	X	X	X	B-4115603	thermostatic capsule steam trap type MST 21 -G, 1/4" -female thread
X	X	X	X	B-4511813	repair kit, inner parts for MST 21
		X	X	E-4111702	ball float-steam trap FT14-4,5TV, female thread 1/2", cast iron
		X	X	E-4111704	ball float-steam trap FTS14-4,5TV, female thread 1/2", stainless steel
					<b>Start-up safety switch</b>
X	X	X	X	E-4111952	start-up safety switch, electrical, switching temperature 80°C, with plug
X	X	X	X	E-4111954	start-up safety switch, pneumatic
					<b>Valve ARI</b>
					cast iron type
		X		E-4115092	valve BR440, Kvs 0,25, DN15PN16
		X		E-4115094	valve BR440, Kvs 0,4, DN15PN16
		X		E-4115096	valve BR440, Kvs 0,63, DN15PN16
		X		E-4115098	valve BR440, Kvs 1,0, DN15PN16
		X		E-4115100	valve BR440, Kvs 1,6, DN15PN16
		X		E-4115102	valve BR440, Kvs 2,5, DN15PN16
		X		E-4115104	valve BR440, Kvs 4,0, DN15PN16
		X	X	E-4115106	valve BR440, Kvs 6,3, DN20PN16
			X	E-4115108	valve BR440, Kvs 10,0, DN25PN16
			X	E-4115110	valve BR440, Kvs 16,0, DN32PN16
			X	E-4115112	valve BR440, Kvs 25,0, DN40PN16
					stainless steel type
X				E-4511738	valve BR440, Kvs 0.25, DN15PN40
X				E-4511740	valve BR440, Kvs 0.4, DN15PN40
X				E-4511742	valve BR440, Kvs 0.63, DN15PN40
X				E-4511744	valve BR440, Kvs 1 ,0, DN15PN40
X				E-4511746	valve BR440, Kvs 1 ,6, DN15PN40
X				E-4511748	valve BR440, Kvs 2,5, DN15PN40
X				E-4511750	valve BR440, Kvs 4,0, DN15PN40
X	X			E-4511752	valve BR440, Kvs 6,3, DN20PN40
X	X			E-4511754	valve BR440, Kvs 10,0, DN25PN40
		X		E-4511756	valve BR440, Kvs 16,0, DN32PN40
		X		E-4511758	valve BR440, Kvs 25,0, DN40PN40

Version A		Version C		Artikelnummer	
Typ		Typ			
20	40	20	40		
<b>Steam lance</b>					
X		X		E-4111000	steam lance 20, Code 1, 218 mm fitting length
x		X		E4111002	steam lance 20, Code 1.5, 393 mm fitting length
X		X		E-4111004	steam lance 20, Code 2, 568 mm fitting length
X		X		E-4111006	steam lance 20, Code 3, 838 mm fitting length
X		X		E-4111008	steam lance 20, Code 4, 1148 mm fitting length
X		X		E-4111010	steam lance 20, Code 5, 1408 mm fitting length
X		X		E-4111012	steam lance 20, Code 6, 1718 mm fitting length
X		X		E-4111014	steam lance 20, Code 7, 2018 mm fitting length
X		X		E-4111016	steam lance 20, Code 8, 2318 mm fitting length
X		X		E-4111018	steam lance 20, Code 9, 2628 mm fitting length
X		X		E-4111020	steam lance 20, Code 10, 2938 mm fitting length
X		X		E-4111022	steam lance 20, Code 11, 3238 mm fitting length
X		X		E-4111024	steam lance 20, Code 12, 3548 mm fitting length
	X		X	E-4111050	steam lance 40, Code 1, 217 mm fitting length
	X		X	E-4111052	steam lance 40, Code 1.5, 392 mm fitting length
	X		X	E-4111054	steam lance 40, Code 2, 567 mm fitting length
	X		X	E-4111056	steam lance 40, Code 3, 837 mm fitting length
	X		X	E-4111058	steam lance 40, Code 4, 1147 mm fitting length
	X		X	E-4111060	steam lance 40, Code 5, 1407 mm fitting length
	X		X	E-4111062	steam lance 40, Code 6, 1717 mm fitting length
	X		X	E-4111064	steam lance 40, Code 7, 2017 mm fitting length
	X		X	E-4111066	steam lance 40, Code 8, 2317 mm fitting length
	X		X	E-4111068	steam lance 40, Code 9, 2627 mm fitting length
	X		X	E-4111070	steam lance 40, Code 10, 2937 mm fitting length
	X		X	E-4111072	steam lance 40, Code 11, 3237 mm fitting length
	X		X	E-4111074	steam lance 40, Code 12, 3547 mm fitting length
<b>Piping</b>					
X	X	X	X	E-4111980	Pipe 8x1mm, for pre heating system
		X	X	E-4111984	Connecting screw, for lance heating, steel zinc plated
X	X			E-4112984	Connecting screw, for lance heating, stainless steel
X		X		B-4111981	steam lance piping in center for 2 lances, type 20, 300 mm fitting length
X		X		B-4111983	steam lance piping in center for 2 lances, type 20, 450 mm fitting length
	X		X	B-4111989	steam lance piping in center for 2 lances, type 40, 300 mm fitting length
	X		X	B-4111991	steam lance piping in center for 2 lances, type 40, 450 mm fitting length
X		X		B-4111935	connection for another steam lance, type 20, 300 mm length
X		X		B-4111937	connection for another steam lance, type 20, 450 mm length
	X		X	B-4111943	connection for another steam lance, type 40, 300 mm length
	X		X	B-4111945	connection for another steam lance, type 40, 450 mm length
<b>Actuators and accessories</b>					
X	X	X	X	E-4111680	actuator, electrical, 24V/0-10V or 4-20mA control signal
X	X	X	X	E-4115082	actuator pneumatic, PN9220E, control signal 0,2 - 1 bar proportional, without accessories
				E-4111662	EP5 positioner, electropneumatic
				E-4111666	PP5 positioner, pneumatic, control signal 0,2 - 1,0 bar
				E-4111668	gauge block for PP5, complete with 1 x 2barg and 1 x 7barg

For ordering spare parts, a template can be found on the [www.hygromatik.com](http://www.hygromatik.com) website under the „Contact“ tab. Your spare parts order may as well be directed per e-mail to the HygroMatik main office using the address [hy@hygromatik.de](mailto:hy@hygromatik.de).

Please make sure to specify your unit model and serial number.



This page intentionally left blank

## 14. Technical Data

Technical Data Separator					
Typ		DDS 20		DDS 40	
Version		A	C	A	C
Thread connections	B	1/4"			
	C	1/2" inner thread			
	C2	1/2" external thread	/	1/2" external thread	/
	O	1" inner thread	3/4" external thread	1 1/2" inner thread	1 1/2" external thread
	I	DN 25 Flange	3/4" inner thread*	DN 40 Flange	1 1/2" inner thread*
Weight [kg]		3,6	1,46	7,3	3,7
Dimensions [mm]	d	/	43	/	70
	e	230	187	340	278
	D	110	104	122	154
	W	175	164	218	236
	h	290	270	426	392
Materials	Housing	1.4404 AISI 316L	1.4301 AISI 304	1.4404 AISI 316L	1.4301 AISI 304
Max. Humidification output [kg/h]		270	180	770	730
Steam Pressure		max 4,5 barg			

\* Connection to the complete system is inner thread (because the strainer is mounted). Separator without strainer has an external thread.

**Separator DDS C**

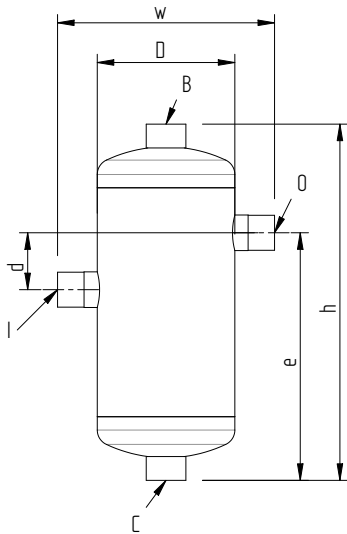

**Separator DDS A**

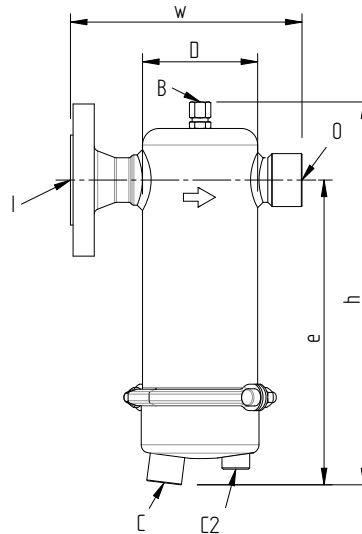

**Strainer DDS C**

Technical Data Strainer			
Strainer 12.1 for version C		Type 20	Type 40
Nominal pressure setting		PN 25	
Female thread		3/4"	1 1/2"
Weight		0,6	2,4
Dimensions [mm]	A	74	108
	B	56	80
	D	32	54
Materials	Housing	1.4408 / AISI 316	

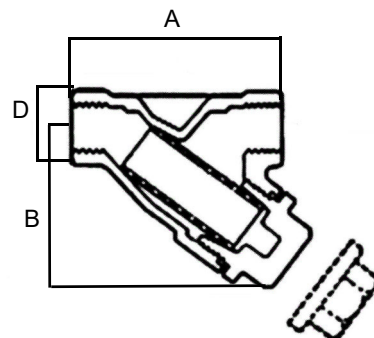

Technical Data Steamlances						
Lancecode	Type 20			Type 40		
	h (mm)	j (mm)	Weight (kg)	h (mm)	j (mm)	Weight (kg)
1	218	338	0,88	218	345	1,54
1,5	392	512	1,14	392	519	1,97
2	568	688	1,4	568	695	2,39
3	838	958	1,8	838	965	3,03
4	1148	1268	2,26	1148	1275	3,78
5	1408	1528	2,65	1408	1535	4,4
6	1718	1838	3,11	1718	1845	5,15
7	2018	2138	3,55	2018	2145	5,87
8	2318	2438	4	2318	2445	6,59
9	2628	2748	4,46	2628	2755	7,34
10	2938	3058	4,92	2938	3065	8,08
11	3238	3358	5,37	3238	3365	8,8
12	3548	3668	5,83	3548	3675	9,55

\*h - installation length

\*j - total length

\*X- Installation length min. 1m (see Steam Lance heating system)

Steam lances are available as type 20 and 40 in various lengths, suitable for duct widths from 280mm to 3855 mm.

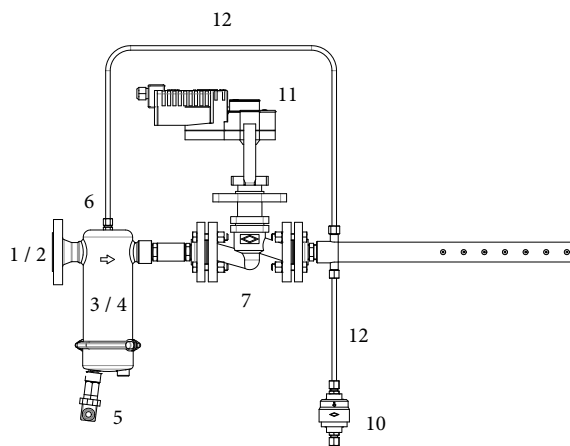

**DDS A**

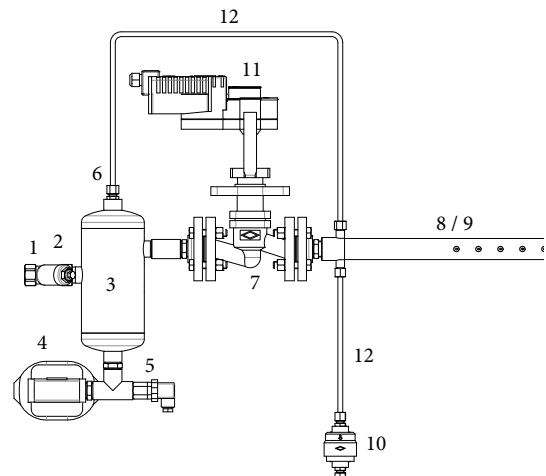

**DDS C**

Duct height	Number of lances
up to 1000 mm	1
1000 - 1700 mm	2
1700 - 2200 mm	3
2200 - 2600 mm	4
over 2600 mm	5

1/2: Separator interface/ Strainer

3: Separator      5: Start-up safety feature

4: Float controlled Condensation Drain

6: connection steam lance heating system

7: control valve    11: Actuator

8/9: Steam lances / steam nozzles

10: Capsule Condensation Drain

12: steam lance heating system

List Lancecodes														
Inst. length h	mm	218	390	568	838	1148	1408	1718	2018	2318	2628	2938	3238	3548
Duct width (max.)*	mm	390	565	835	1130	1405	1715	2015	2315	2625	2935	3245	3545	3855
Duct width (min.)*	mm	220	395	570	840	1150	1410	1720	2020	2320	2630	2940	3240	3550
Lancecode		1	1,5	2	3	4	5	6	7	8	9	10	11	12

# HygroMATIK®

Lise-Meitner-Str.3 • D-24558 Henstedt-Ulzburg  
Phone +49(0)4193/ 895-0 • Fax -33  
eMail [hy@hygromatik.de](mailto:hy@hygromatik.de) • [www.hygromatik.com](http://www.hygromatik.com)  
member of **CAREL Group**

