

Controls

- BS** Basic Spa
- TS** Touch Spa
- TRS** Touch Remote Spa



HSS.EN

Certain computer programs contained in this product [or device] were developed by HygroMatik GmbH ("the Work(s)").

Copyright © HygroMatik GmbH [12.01.2015]
HS Controls EN
All Rights reserved.

HygroMatik GmbH grants the legal user of this product [or device] the right to use the Work(s) solely within the scope of the legitimate operation of the product [or device]. No other right is granted under this licence. In particular and without prejudice to the generality of the foregoing, the Work(s) may not be used, sold, licensed, transferred, copied or reproduced in whole or in part or in any manner or form other than as expressly granted here without the prior written consent of HygroMatik GmbH.

Information in this manual is subject to change or alteration without prior notice.



Warning, Hazardous Voltage: All work to be performed by trained personnel only. All electrical installation and servicing of the electrical components of this unit to be performed by qualified electricians only. Disconnect power supply before installation and servicing!

1. Introduction	4
1.1 Typographic Distinctions	4
1.2 Documentation	4
1.3 Directions for Use	5
2. Safety Notes	6
2.1 Overview	6
2.2 Guidelines for Safe Operation	6
2.3 Disposal after Dismantling	7
3. Short Description of Controls Basic Spa, Touch Spa, Touch Remote Spa	8
3.1 Display and Control Unit Overview	9
3.2 Operating Status LED	10
3.3 Quick Access Functions Overview	11
4. Overview of Steam Bath Operation and Installation	12
4.0.1 Steam Bath Installation (Schematic Layout)	13
4.0.2 Steam Bath - Temperature Control	14
5. Operation of the Touch/Remote - User Level and Operator Level	16
5.1 Access to Operator Level	16
5.2 Menu Overview:	16
5.3 Menu Scheme	17
5.3.1 Menu Steam bath	18
5.3.2 Menu Timer	20
5.3.3 ECO Mode	22
5.3.4 Device Configuration	24
5.3.5 Operator Menu:	27
6. Mechanical Installation	30
6.1 Temperature Sensor Installation	30
6.2 Peristaltic Pump	31
6.3 Fan	31
6.4 Light	31
7. Parameters	32
8. Electrical Connection	34
8.1 Power Supply	34
8.2 Remote Switch / Safety Interlock	34
8.3 Function Steam Boost	35
8.4 Switch Outputs for the Messages Collective Fault, Exhaust Fan, Essence (1) and Light	35
8.4.1 24V or 230V Connections	36
8.5 Relay Box Option	38
8.5.1 230V Relay Box	39
8.5.2 24V Relay Box	40
9. Initial Operation	41
10. Wiring Diagram	42
11. Faults and Messages / Conditions	46
12. Technical Specifications	51

1. Introduction

Dear Customer,

Thank you for choosing a HygroMatik steam generator.

HygroMatik steam generators represent the latest in humidification technology.

They will impress you with their safety, ease of use and economical operation.

In order to operate your HygroMatik steam generator safely, properly and efficiently, please read these operating instructions.

Employ your steam generator only in sound condition and as directed. Consider potential hazards and safety issues and follow all the recommendations in these instructions.

If you have additional questions, please contact us:

Tel.: +49-(0)4193 / 895-0 (Main Number)

Tel.: +49-(0)4193 / 895-293 (Technical Support Hotline)

Fax: +49-(0)4193 / 895-33

e-mail: hot1@HygroMatik.de

For all technical questions or spare parts orders, please be prepared to provide unit type and serial number (see name plate on the unit).

1.1 Typographic Distinctions

- preceded by a bullet: general specifications.
- » preceded by an arrow: Procedures for servicing or maintenance which should or must be performed in the indicated order.
- Installation step which must be checked off.
- italics* Terms used with graphics or drawings.

1.2 Documentation

Scope of supply

The delivery of the HeaterSlim humidifier also contains two technical manuals. One for the unit and one for the control.

Retention

Please retain these operating instructions in a secure, always accessible location. If the product is resold, turn the documentation over to the new operator. If the documentation is lost, please contact HygroMatik.

Versions in Other Languages

These operating instructions are available in several languages. If interested, please contact HygroMatik (www.hygromatik.com) or your HygroMatik dealer.

1.3 Directions for Use

The HygroMatik steam generator is exploited to produce steam using different tap water qualities or partial softened water (all humidifier types) or fully demineralized water / condensate water (only for heater type humidifiers).



Warning: HygroMatik steam generators emit steam with a temperature of 100° C. The steam should not be inhaled directly.

Only qualified and authorised personnel may operate the unit. Persons transporting or working on the unit, must have read and understood the corresponding parts of the Operation and Maintenance Instruction and especially the chapter „Safety Notes“. Additionally, operating personnel must be informed of any possible dangers. You should place a copy of the Operation and Maintenance Instruction at the unit's operational location (or near the unit).

The steam humidifier is not qualified for exterior application.

2. Safety Notes

2.1 Overview

These safety notes are required by law. They promote workplace safety and accident prevention.

Warnings and Safety Symbols

The safety symbols below identify sections containing warnings about hazards or potential dangers. Please familiarize yourself with these symbols.



Warning: Failure to observe this warning may result in serious injury or death and/or damage to the unit.



Danger, Hazardous Voltage: Hazardous electrical current! Failure to observe this warning may result in injury or even serious injury or death.



Warning: Failure to follow these instructions may result in damage to the unit due to electrostatic discharge. The electronic components of the humidifier control are very sensitive to electrostatic discharges. In order to safeguard these components during installation and servicing, steps must be taken to protect against ESD.



Reminder: Materials and consumables must be handled and/or disposed of as required by law.



Note: Appears before explanations or cross-references which refer to other sections of the operating instructions.

2.2 Guidelines for Safe Operation

Overview

Obey all safety notes and warnings present on the unit.

In case of a malfunction, switch off the unit immediately and prevent a restart. Repair malfunctions promptly.

After any repair work, have qualified personnel check the safe operation of the unit.

Use original spare parts only.

Additional national safety regulations also fully apply to the operation of this unit.



Warning: Ensure that no skin contact to hot steam can occur in the immediate area of the steam feed.



Warning: Ensure that possible condensate from the location of the steam feed cannot fall onto the skin.

Accident Prevention Regulations

Please comply with the relevant accident prevention regulation to prevent injury to yourself and others.

Operation of the Unit

Do not perform any work which compromises the safety of the unit.

Regularly check that all safety and monitoring devices are functioning normally.

Do not remove or disable safety devices.

Installation, Dismantling, Maintenance and Repair of the Unit

Disconnect unit components from power supply prior to maintenance or repair work.

Attaching or installing **additional components** is permitted only with the **written consent** of the manufacturer.

When installing a humidifier in a room without a drain, a safety device must be provided in the room to ensure closure of the humidifier's water supply in the event of a leak.

Electrical

Work on the electrical system must be performed by qualified personnel.

Disconnect unit components from power supply prior to work.

In case of a malfunction in the electrical power supply, switch off the unit immediately.

Use only original fuses with the appropriate amperage rating.

Regularly check the unit's electrical equipment. Promptly repair any damage, such as loose connections or burned wiring. After proper electrical installation or repair, test all safety mechanisms (such as grounding resistance).

HeaterSlim steam humidifiers are IP20 protected. Make sure that the unit is protected from drips in its installed location.

2.3 Disposal after Dismantling



Note: The operator is responsible for the disposal of unit components as required by law.

3. Short Description of Controls Basic Spa, Touch Spa, Touch Remote Spa

In the TouchSpa and the Touch Remote Spa version, communication with the HygroMatik steam generator is allowed by using the display and control unit.

The Basic control is delivered without display and control unit and can be operated only with the pre-set parameters.

Steam generator
HeaterSlim Touch Remote Spa
(HS-TRS)



The remote control is put in the charging cradle for charging. It can be easily wall-mounted using a retaining bracket or simply placed in the table holder. Out of the charging cradle, the remote control can be operated for up to three hours by the installed rechargeable battery. The

charging cradle is firmly connected to the steam generator via a communication and supply line.

Steam generator
HeaterSlim Touch Spa
(HS-TS)



The display and control unit is integrated in the housing of the HeaterSlim Touch steam generator.

Steam generator
HeaterSlim Basic
(HS-BS)



Steam generator HeaterSlim Basic is delivered without display and control unit. The steam generator is operated with the pre-set factory parameters.

If there is a failure, the LED in the main switch is flashing. If the steam generator is equipped with a display, additionally failure messages are reported and the operating status LED is flashing red.

3.1 Display and Control Unit Overview

The display is designed as a backlit touchscreen, when the humidifier is switched on, it shows:

- the HygroMatik logo (or an alternative logo) and the time
- an overview bar for the current states of the functions:

Symbol	Status	Description
	permanently on	preset Timer mode is activated
	blinking	Steam generator works just in the preselected Timer mode
	blinking	the communication between the display and control unit and the steam generator is disturbed
eco	permanently on	the steam generator is in the preselected ECO mode
	permanently on	the steam humidifier has the release for steam production
	permanently on	essence pump A, B or C is selected for operation
	blinking	a selected essence pump is just in operation
	permanently on	relay output for light is switched
	permanently on	supply fan or exhaust fan function is active
	blinking	supply fan or exhaust fan is working
Failure message	permanently	In the fault case the steam generator switches off and distributes a specific fault text message

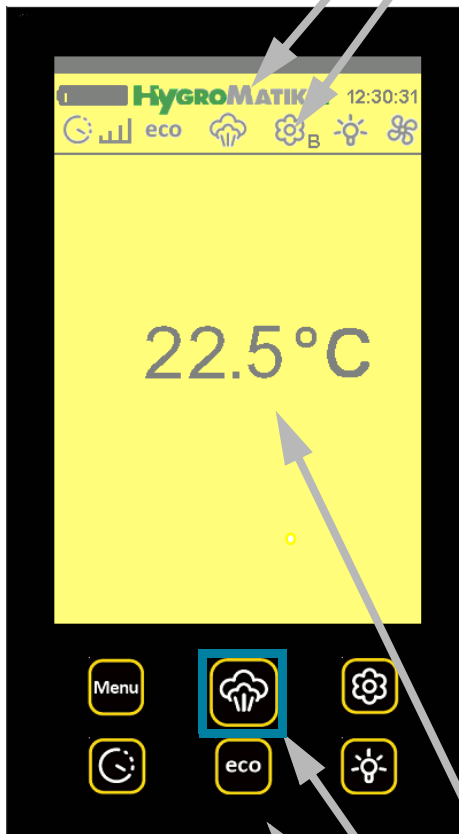

- the current actual temperature in the steam bath / further menus with parameter setting options (touch screen interface). If an invalid temperature is measured, it is shown by arrows (up or down) so.
- Operating status LED
- Six quick access keys for steam bath functions: Tapping the quick access keys provides quick access to the most frequently used functions:
 - Menu**
 - Release** steam production
 - Essence** pump
 - Timer** function
 - ECO** function
 - Light** function



Touch screen information:

Tap in the centre of an icon to select it.

Please touch the touchscreen only lightly. It is sensitive enough to react to the lightest touch.

3.2 Operating Status LED

The operating status LED indicates different operating states with different colors.

These are:

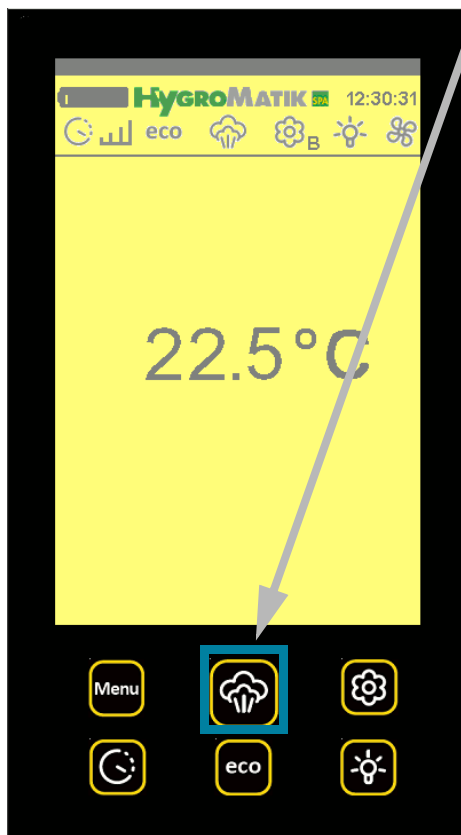

LED color	Operating status
light blue	Filling (the steam cylinder is supplied with water)
white	Ready for use (the safety chain (clamp 1/2) is open; the device is not released for operation)
dark blue	ECO (device operates in ECO mode)
orange	No requirement (the requirement is below the switching-on point of the steam humidifier)
green	Humidifying (steam is produced)
green blinking	Service message
purple	Blow-down (cylinder water is blown-down)
flashing red	Error (the device is switched off with an error message on the display)
flashing yellow	Safety stop (the device is switched off after the pre-set time of the <i>Limitation of operating time</i>)
black	no communication

3.3 Quick Access Functions Overview

Menu function
Tapping on the key **MENU** takes you to the main menu with the submenus:

- Steam bath
- Timer
- ECO
- Device configuration
- Language

Timer function
Tapping the key can change the timer function. If the timer function is switched on, this icon appears in the status bar:



If the timer icon is blinking the unit is producing steam in a timer interval. The control can switch daily or weekly operating time intervals that can be set on operator level.

ECO function
If the ECO function is activated, the steam generator stops actual steam operation and this icon appears in the status bar:

eco

Steam generation is actuated regularly, but the steam generator is working on reduced output.

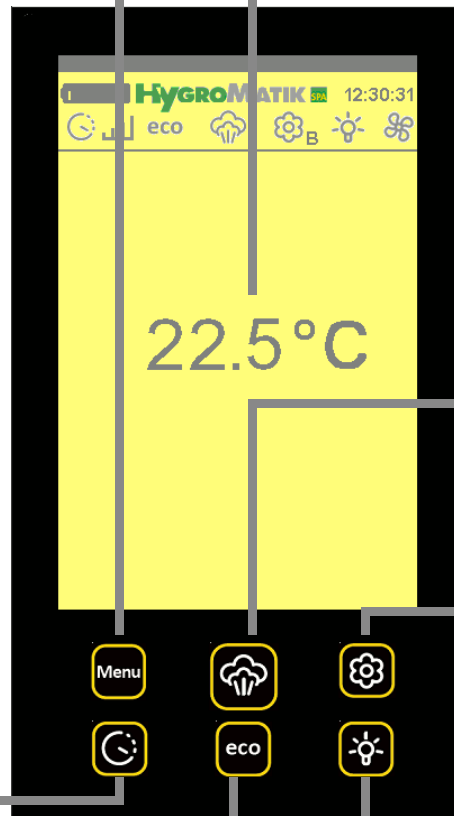

Set temperature value
Tap on the display in the position where the temperature is shown. You can change the set temperature with the displayed up or down arrows.

Release steam production
If tapping this button the unit is released to produce steam and the status bar shows:



Essence function
Tapping this key several times allows you to select essence pump A, B, or C to be active or if essence supply is to be switched off completely. The status bar, is e.g., shown with selection of essence B:



If the essence icon is not shown in the status bar, essence supply is switched off.

If the essence icon is blinking, an essence pump is working.

Light function
Tapping the key can switch the light function on or off. If the light function is switched on, the light icon appears in the status bar:



4. Overview of Steam Bath Operation and Installation

The necessary steam for the operation of the steam bath is supplied by the HygroMatik Steam Generator. The recorded temperature in the steam bath is the only control variable for controlling steam production. At the default setting, the steam bath achieves a temperature of about 45°C at 100% relative humidity. A steam bath air supply fan may be used to deliver fresh air, and an exhaust fan to remove warm air from the steam bath, in order to ensure continuous steam supply and a stable temperature control.

Heat-Up Phase:

Steam is supplied to the still cold steam bath, increasing the relative humidity to 100% at an initially constant temperature. Subsequent steam delivery then increases the temperature; the relative humidity remains at 100%.

Operating Phase:

When the desired temperature (plus hysteresis) is reached, steam production is interrupted. If the steam bath temperature falls below the desired value, steam is again delivered into the cabin.



Warning: Inside the steam cabin, safe low voltage (24V) should be employed for the fan and light.

4.0.1 Steam Bath Installation (Schematic Layout)

Location	Designation
1	Steam generator
2	Essence peristaltic pump
3	Essence reservoir
4	Essence line to steam hose
5	T-piece for essence feed into the steam hose
6	Steam hose
7	Steam manifold /steam nozzle in steam bath
8	Supply fan
9	Temperature sensor
10	Exhaust fan
11	Cabin light

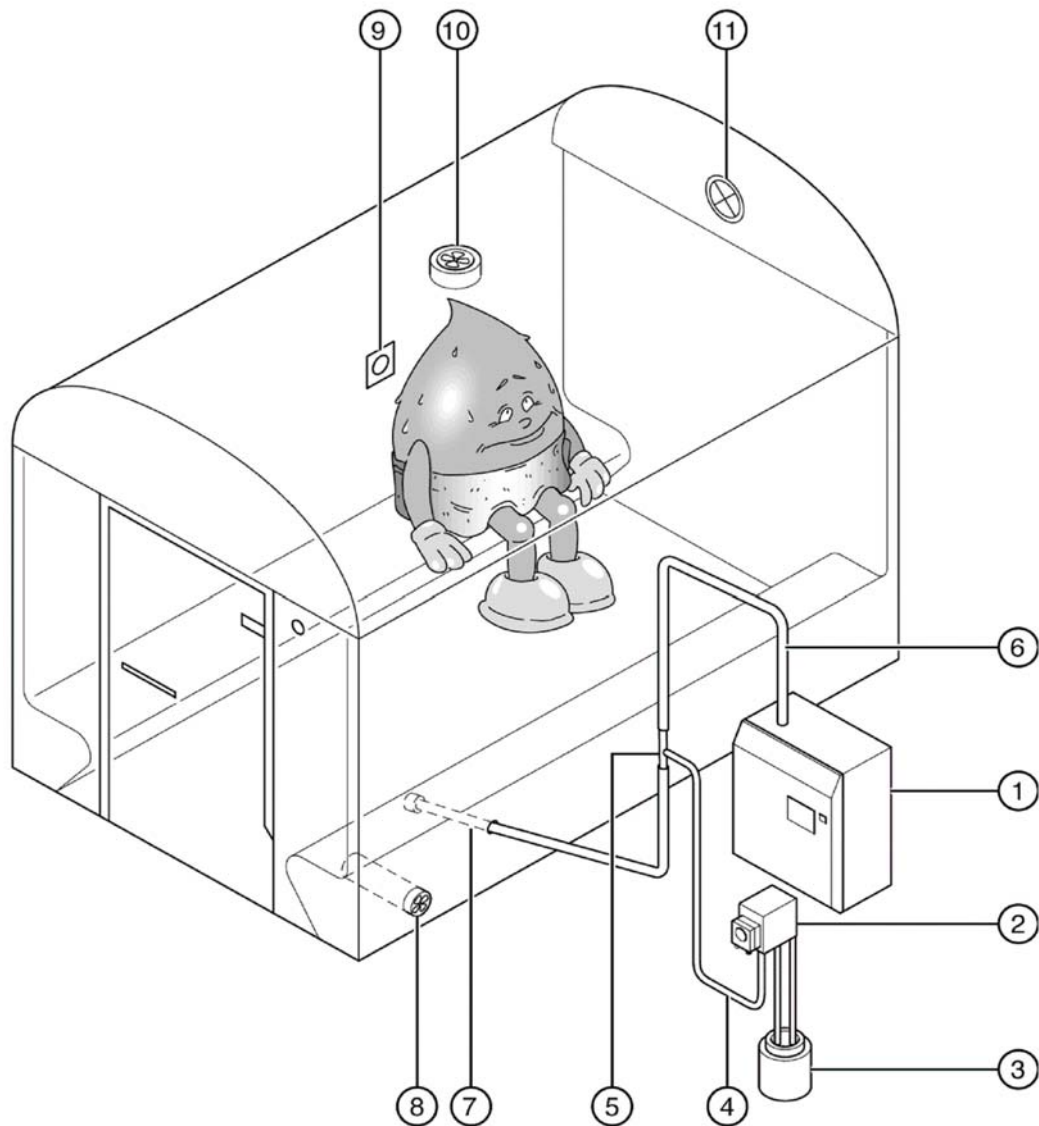

4.0.2 Steam Bath - Temperature Control

With any steam bath, a temperature sensor must be installed in the cabin. The temperature sensor measures the **temperature** in the steam bath and is connected to the steam generator.

The control supervises the HygroMatik steam production according to the temperature reading. The **relative humidity** is not measured since it is **always 100%** following the heat-up phase.

In addition, depending on your order preference, you can connect an essence injector, light and fan to the steam generator.

The sample diagram below shows how the Control of a Heater-Slim unit with one heater element functions:

Parameters G1 to G4 + G13 (may only be modified in operating mode) are programmed as follows:

Hysteresis Temperature Controller (G1)=	0.5K
Hysteresis Steam Bath Exhaust Fan (G3) =	0.5K
Hysteresis Steam Bath Supply Fan (G13) =	0.5K
Steam Bath Temperature Set Value =	45°C

If the temperature in the steam bath falls below **45°C**, an adjustment is made by increasing steam production.

If the temperature in the steam bath rises above **45.5°C**, steam production is shut off.

The release point for the steam generator is determined as follows:

Steam Bath °C Set Value (G2)+Hysteresis °C-Controller (G1) =
 $45^{\circ}\text{C} + 0.5\text{K} = 45.5^{\circ}\text{C}$.

If the temperature in the steam bath rises above the programmed temperature set value of 45°C, the Control activates the steam bath exhaust fan. The control switches off the exhaust fan below 44°C. The release point for the steam bath exhaust fan is determined as follows:

Steam Bath °C Set Value (G2) -
Hysteresis °C Steam Bath Exhaust Fan (G3) =
 $45^{\circ}\text{C} - 0.5\text{K} = 44.5^{\circ}\text{C}$

Steam is only produced as long as the temperature in the steam bath remains below the "set temperature value." If the temperature in the steam bath remains above the "set temperature value" for a long period of time, resulting in this case in **no visible steam** production, this could be due to:

- excessively high heat supply from an additional source, e.g. from heated benches.
- a well-insulated steam bath
- too little air flow in the steam bath.

Air flow in the steam bath is facilitated by a steam bath exhaust fan, causing the temperature in the steam bath to fall more quickly. Renewed steam production compensates for the drop in temperature. In this way, the fan ensures constant, stable steam production - with visible steam in the cabin.

4.0.2.1 Diagram Temperature Profile in Steam Bath

Temperature Profile in Steam Bath using a HeaterSlim unit with one heater element

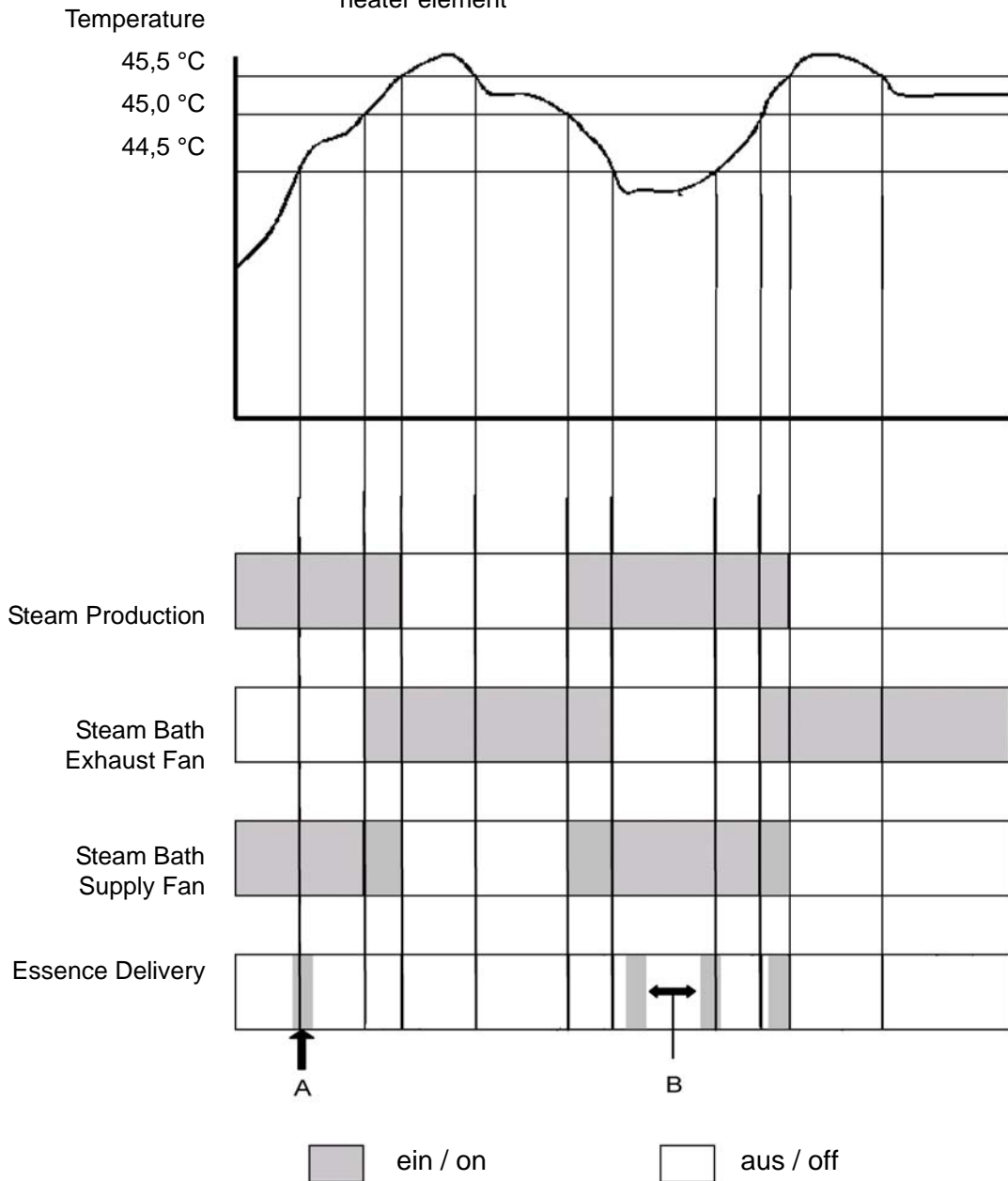

Note: In HeaterSlim units with 2 or 3 heater elements these are turned off at the following temperatures:

Unit with 2 heater elements:

Switch off temp. 2nd heater element= $G1+G2+0.5\text{ K}$ here: $46.0\text{ }^\circ\text{C}$

Unit with 3 heater elements:

Switch off temp. 2nd heater element= $G1+G2+0.5\text{ K}$ here: $46.0\text{ }^\circ\text{C}$

Switch off temp. 3rd heater element= $G1+G2+0.5\text{K}+0,5\text{K}$ here: $46.5\text{ }^\circ\text{C}$

The restarting of the heater elements is done simultaneously if the temperature comes under the programmed temperature set value.

5. Operation of the Touch/Remote - User Level and Operator Level

You reach the user level after turning on the HygroMatik steam generator.

The **user level** allows limited access to the most important parameters for daily use.

The **operator level** also provides expanded access to all parameters. Only password entry activates the operator level. If there has not been an entry for a period of 15 minutes, control automatically switches back to the user level.



Note: The functions that are accessible only on operator level are highlighted in grey in the following description.

5.1 Access to Operator Level

Approach:

Selecting **Menu / Device functions** offers access to the submenus "Password level" and "Key tones".

Password level
Code 000 -> code 010

- » Please select *Password level*
- » Select *Password entry*
- » Type in code 010 for settings
- » Quit the menu with 

5.2 Menu Overview:

Steam bath] limited access on user level and expanded access on operator level
Timer	
ECO	
Device configuration	
Language	
Operator menu] access on operator level only

5.3 Menu Scheme

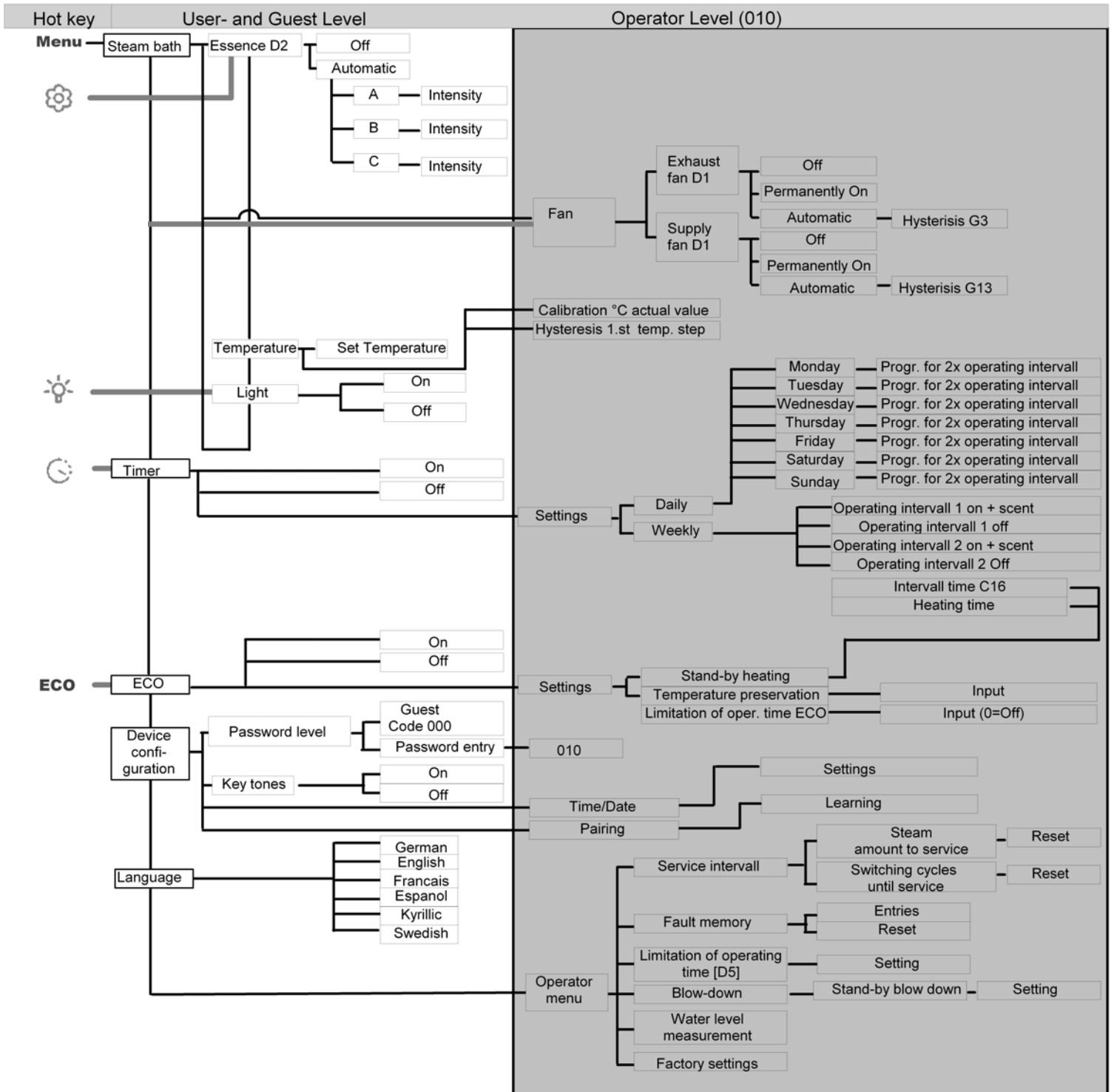

5.3.1 Menu Steam bath

Approach:

Selecting **Menu / Steam bath** offers you the following submenus.

Essence

Temperature

Light

Fan (visible only on operator level)

5.3.1.1 Essence

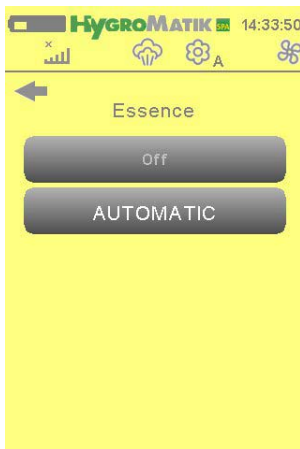

- » Select *Steam bath*
- » Select *Essence*

Switching off essence supply:

- » Select *Off* to switch off essence supply
- » Quit the menu with 

Selection, intensity setting of an essence pump:

- » Select *AUTOMATIC*
 - » Select one of the three essence pumps A, B or C
- Selection of essence A is the factory setting during commissioning of the steam generator.

Intensity

- » Select *Intensity* to set the intensity of the essence
- » Select a value between 1 (= very low intensity)
10 (= very high intensity)

(The intensity default setting is 5. This corresponds to an essence injection time of 3 seconds, and a time interval between the injections of 5 minutes.

If the factory-set intensity value is reduced, thus increasing the pause time. If the intensity value increases, thus increasing the injection time.)

5.3.1.2 Temperature

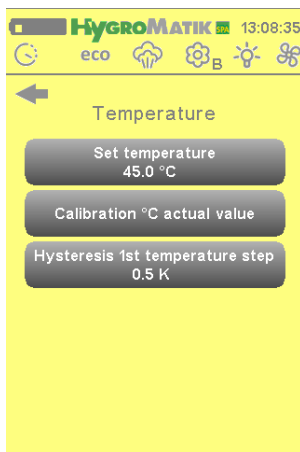

- » Select *Steam bath*
- » Select *Temperature*

Changing the set temperature of the steam bath:

- » Select *Set temperature*, to change the set temperature
- » Select a value between 20°C and 49°C and confirm the entry
- » Quit the menu with 

Correction of the indicated actual temperature (for temperature sensor calibration):

- » Select *Calibration °C actual value*
- » Select a value between -20K and +20K and confirm the entry
- » Quit the menu with 

Adjusting the hysteresis of the temperature control:

- » Select *Hysteresis 1st temperature step*
- » Select a value between 0K and +5K (entry in 0.5K steps possible) and confirm the entry
- » Quit the menu with 

5.3.1.3 Light

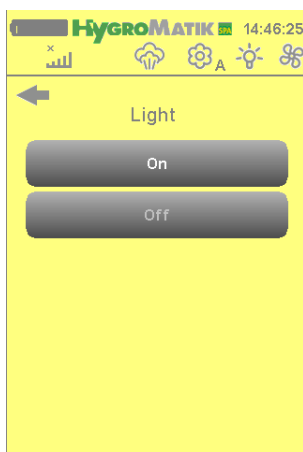

- » Select *Steam bath*
- » Select *Light*

Light (on/off)

- » Select *On* to switch on light control or
- » Select *Off* to switch off light control
- » Quit the menu with 

5.3.1.4 Fan



- » Select *Steam bath*
- » Select *Fan*
- » Select *Exhaust fan* or *Supply fan* to set the switching function of the according fan

Switching function of exhaust fan and supply fan

Switch off

- » Select *Off* to switch off the fan function
- » Quit the menu with 

Switch on permanently

- » Select *Permanently On* to set the according fan for permanent operation
- » Quit the menu with 

Changing the switch off temperature of the fan

- » Select *Automatic*
- » Select *Hysteresis* to set the temperature hysteresis (set temperature minus *hysteresis* = switch off temperature of the fan) of the according fan
- » Select a value between 0K and +5K and confirm the entry
- » Quit the menu with 

5.3.2 Menu *Timer*

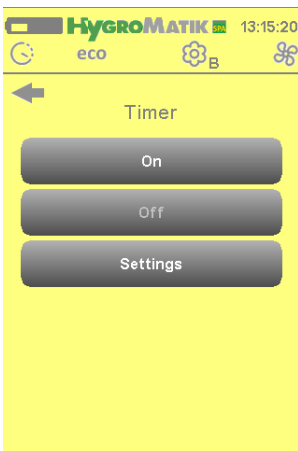

Approach:

Selecting *Menu / Timer* offers you the following submenus.

- On**
- Off**
- Settings**

5.3.2.1 On

- » Select *On* to switch on the timer function
- » Quit the menu with 

5.3.2.2 Off

- » Select *Off* to switch off the timer function completely
- » Quit the menu with 

5.3.2.3 Settings

There is a choice between a daily and a weekly timer mode.

If the timer is in the **Daily** mode, the steam generator is released for operation for two freely definable time intervals a day. These time intervals can be set **differently** for **every day of the week** (Monday - Sunday). You can additionally specify which essence pump is to be active in the respective time interval and the function of the ECO mode can be set in parallel. Time intervals are not pre-programmed with the factory setting at delivery.

If the timer is in the **Weekly** mode, the steam generator is released for operation for two freely definable time intervals a day. These time intervals are **identical for every day of the week**.

You can additionally specify which essence pump is to be active in the respective time interval and the function of the ECO mode can be set in parallel. Time intervals are not pre-programmed with the factory setting at delivery.

5.3.2.4 Daily

- » Select *Daily* to release the steam generator for operation for the specified, daily time intervals
- » Quit the menu with  or continue with the:

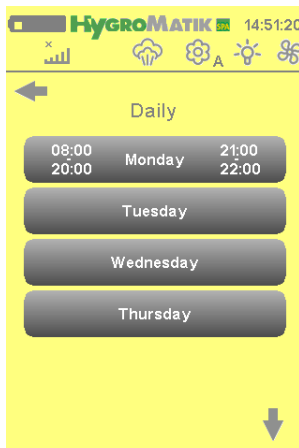

Setting of the time intervals:

- » Select the day of the week (*Monday to Sunday*) for which you can set up to two operation time intervals
- » Select *Interval 1 On*, to set the starting time of the 1st operation time interval and the then applicable allocation of the desired essence pump (select from A, B or C) as well as the ECO mode (select *ECO On* or *ECO Off*)
- » Select the time (e.g.: 12:45) and enter the starting time in the *hh:mm* format and confirm the entry
- » Select *Interval 1 Off* to set the stopping time of the 1st operation time interval
- » Quit the menu with  or continue with the settings of *Interval 2 On* and *Interval 2 Off* (setting is done analogous to setting Interval 1)



5.3.2.5 Weekly

- » Select *Weekly* to release the steam generator for operation for the specified, daily time intervals
- » Quit the menu with  or continue with the:

Setting of the time intervals:

- » Select *Interval 1 On*, to set the starting time of the 1st operation time interval and the then applicable allocation of the desired essence pump (select from A, B or C) as well as the ECO mode (select *ECO On* or *ECO Off*)
- » Select the time (e.g.: 12:45) and enter the starting time in the *hh:mm* format and confirm the entry
- » Select *Interval 1 Off* to set the stopping time of the 1st operation time interval
- » Select the time (e.g.: 16:45) and enter the starting time in the *hh:mm* format and confirm the entry
- » Quit the menu with  or continue with the setting of *Interval 2 On* and *Interval 2 Off* (setting is done analogous to setting Interval 1)

5.3.3 ECO Mode

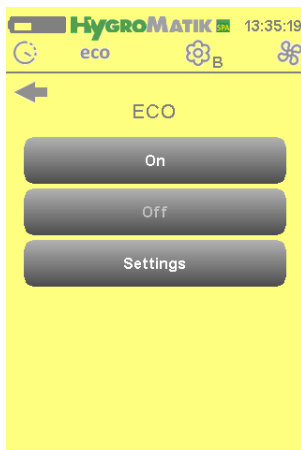

The steam generator stops actual steam operation if the ECO function is activated. The **eco** icon appears in the status bar. The steam cylinder is actuated regularly but the steam generator is working on reduced output.

Approach:

Selecting *Menu / ECO mode* offers you the following submenus.

On

Off

Settings

5.3.3.1 Switch on ECO Mode

- » Select *On*
- » Quit the menu with 

5.3.3.2 Switching off ECO Mode

- » Select Off
- Quit the menu with 

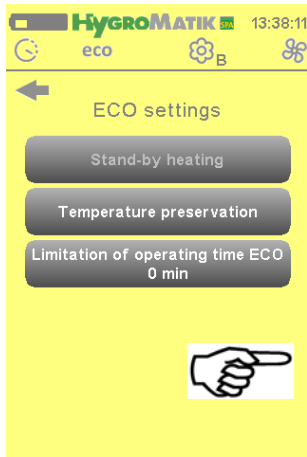

5.3.3.3 Settings

- » Select *Settings*
- » Select between the function *Stand-by heating*, *Temperature preservation [°C]* and *Limitation of operating time [min]*
- » Quit the menu with  or
- » Go to the setting of the functions *Stand-by heating* or *Temperature preservation [°C]* and the setting for *limitation of operating time*

Note: Stand-by heating and Temperature preservation [°C] cannot be active simultaneously.

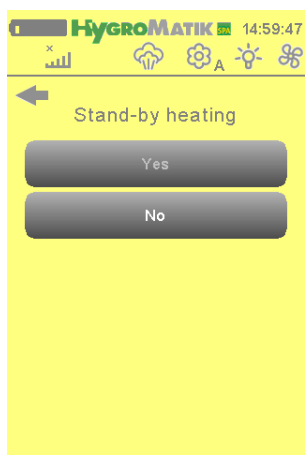

Stand-by heating

During Stand-by heating, actual steam bath operation (steam production) is interrupted. But the **cylinder water is heated** periodically for a set *heating time*. The set *Interval Stand-by heating* is followed by the next heating time.

- » Select *Stand-by heating*
- » Select *Interval time* (entry of the time in minutes) or *Heating time* (entry of the time in seconds)
- » Set the desired duration and confirm the entry
- » Quit the menu with  |

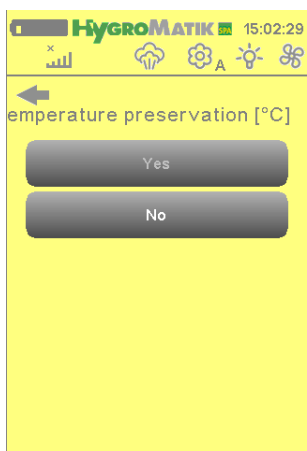

Temperature preservation [°C]

During Temperature preservation [°C], actual steam bath operation (steam production) is interrupted. But the steam bath is now kept at a set temperature below the standard value.

- » Select *Temperature preservation [°C]*
- » Select the *shown temperature value*
- » Set the desired temperature preservation value and confirm the entry
- » Quit the menu with  |

Limitation of operating time ECO

With this parameter you can set how long the steam generator works in ECO mode. Neither exhaust fan nor supply fan run within the ECO operating time.

Limitation of operating time ECO

- » Select *Operator menu*
- » Select *Limitation of operating time ECO*,
- » Enter a new value in minutes a (hint: 0=off)
- » Quit the menu with 

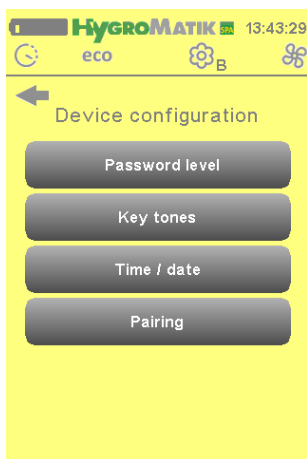

5.3.4 Device Configuration

Selecting *Menu / Device configuration* offers you the following submenus.

Password level

Key tones

time / date

Pairing

5.3.4.1 Password Level

The **Guest level** allows limited access to the most important parameters for daily use. Switching on the device generally takes you to the user level.

The **Operator level** also provides expanded access to all parameters. Only password entry activates the operator level. If there has not been an entry for a period of 15 minutes, control automatically switches back to the guest level.

Password level
Code 000 -> code 010
 Guest level - Operator level

- » Select *Password level*
- » Select *Password entry*
- » Type in code 010 for settings and confirm input
- » Quit the menu with 

5.3.4.2 Key Tones

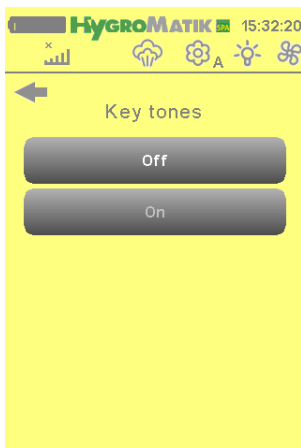

In this menu you can select whether you want to have entries confirmed with a beep when pressing a key.

Key tones (On/Off)

- » Select *On* to switch on the key tone function or
- » Select *Off* to switch off the key tone function
- » Quit the menu with 

5.3.4.3 Time/Date

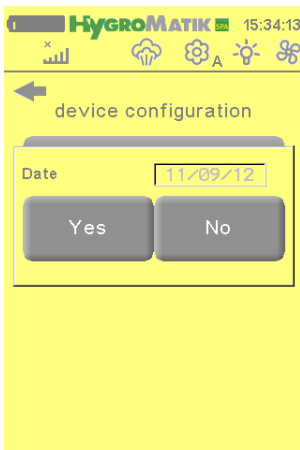

In this menu you can set the time and the date of the steam generator.

Setting

- » Select *Set Time/Date*
- » You will now be asked whether the shown date is correct
- » If yes, please select *Yes*; if not please select *No* (and then please enter the correct date with the TT:MM:YY format)
- » You will now be asked whether the displayed time is correct
- » If yes, please select *Yes*; if not, please select *No* (and then please enter the correct time with the hh:mm:ss format)
- » Quit the menu with 

5.3.4.4 Pairing

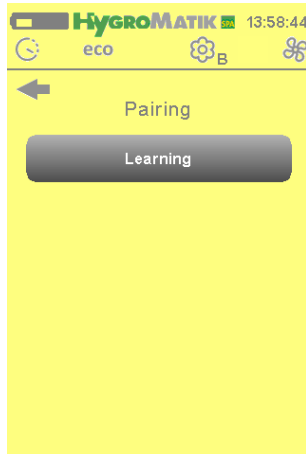

If subsequently a new remote control is to be connected to the humidifier, then this remote control has to be registered at first.

Therefore:

- » Select *learning* while the charging cradle is connected to the turned on steam generator.
- » Then the charging cradle is being prepared.
- » Now, the two pins on jumper JP1 on the board of the charging cradle have to be bridged for 1 second (e.g. with a screwdriver).
- » The connection is established automatically and wirelessly between the remote control and the charging cradle in the vicinity.



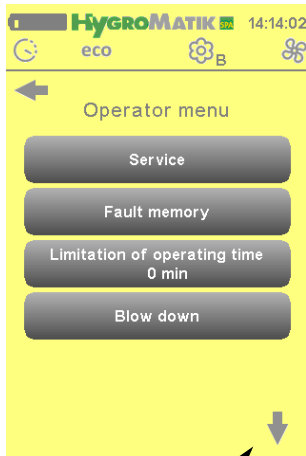

Choosing this arrow expands the menu toward the bottom

5.3.5 Operator Menu:

The Operator menu contains the following submenus:

- Service
- Error memory
- Limitation of operating time
- Blow down
- Water level measurement
- Factory setting

5.3.5.1 Service

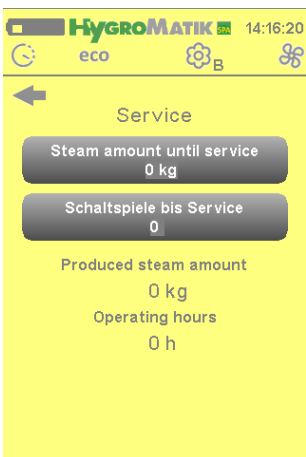

Reset maintenance interval

The control reports the expiration of the service interval on the display via the green flashing operating status LED or the corresponding error code on the control switch (see chapter "Faults and messages"). The service interval is displayed when a certain amount of steam (dependent on the adjusted water quality to the DIP switches -> see technical manual for HeaterSlim) was produced or the preset number of switching cycles (1000000) of the main contactor has been reached. The service message can be reset as follows:

- » Select *Operator menu*
- » Select *Service*
- » Select *Steam amount until service* or alternatively *Switching cycles to Service*
- » Select *Reset* to restore the service interval
- » Quit the menu with |

Display of produced amount of steam and total operation time

- » Select *Service*. The produced amount of steam [kg] and the total operation time [h] are displayed
- » Quit the menu with |

5.3.5.2 Error Memory

Display of last errors

- » Select *Operator menu*
- » Select *Fault memory*
- » Select *Entries* for a list of the last error messages
- » Quit the menu with |

Resetting the error memory

- » Select *Operator menu*
- » Select *Fault memory*,
- » Select *Reset* to delete all stored error messages and confirm entry
- » Quit the menu with  |

5.3.5.3 Limitation of Operating Time

With this parameter you can set whether and after how many minutes the steam generator is switched off after the safety chain has been closed.

If the steam generator is switched off, the operating status LED will light up orange. Opening and closing the safety chain restarts the steam generator for operation for the set number of hours.

Limitation of operating time

- » Select *Operator menu*
- » Select *Limitation of operating time*
- » Enter a new value in minutes a (hint: 0=off)
- » Quit the menu with  |

5.3.5.4 Blow-down

In the Blow-down submenu, you can set the Stand-by blow-down. With the parameter Stand-by blow-down you can set the interval between the opening of the safety chain and the subsequent automatic full blow-down.

Setting the Stand-by blow-down

- » Select *Operator menu*
- » Select *Blow down*,
- » Select *Stand-by blow down*
- » Enter a new value in minutes a (hint: 0=off)
- » Quit the menu with  |

5.3.5.5 Water Level Measurement

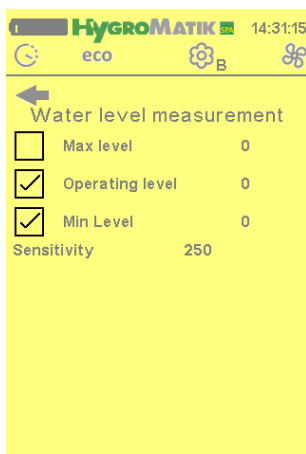

In the menu "Water level measurement" the currently recorded water level is represented. In the left example shown, it can be seen that the sensors for Min level and Operating level have water contact, i.e. the unit is filled with water to operating level.

5.3.5.6 Factory Setting

In the *Factory settings* menu you can reset all parameters to the delivery condition.

- » Select *Operator menu*
- » Select *Factory settings*,
- » Confirm or reject the resetting of the parameters to factory setting
- » Quit the menu with  |

6. Mechanical Installation

6.1 Temperature Sensor Installation

With steam baths, a temperature sensor must be installed in the cabin. The sensor measures the active temperature and sends the value to the control. The recorded temperature constitutes a control variable for controlling steam production.

Please note:

- Do not install the sensor close to the steam manifold.
- Mount the sensor on the wall and not in or under the wall paneling.



Note: The best installation location for the temperature sensor is 800 - 1000 mm above the bench surface (about the head height of the steam bather).



Warning: Do not manipulate steam production by tampering with the temperature sensor (e.g. do not douse with cold water or cover).

Temperature Sensor Connection

Connect the temperature sensor cable to the designated terminals 6 and 7 on the HygroMatik steam generator (see chapter „Wiring Diagram“).

Test using the table below. While the sensor has been calibrated in the factory, subsequent adjustment within a range of -5K to +5K is possible using a 2nd temperature gauge.

Temperature Resistance Table	
Temperature in °C	Resistance in kOhm
10	30,4
20	18,8
30	12,0
40	7,8
50	5,2
60	3,6
70	2,5
80	1,8
90	1,3
100	1,0

6.2 Peristaltic Pump

Essence delivery only occurs during steam production. The intensity of essence delivery can be set at the control unit. The essence is injected into the main steam line through an essence feed. HygroMatik supplies the necessary T-piece for this connection.

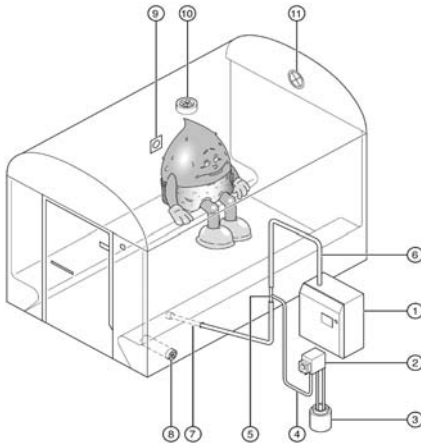

Please note:

- Place essence feed (5) as close as possible to the steam bath.
- Make sure that no essence can flow into the HygroMatik steam generator (1).
- Place peristaltic pump (2) above the essence reservoir (3), but not higher than 1.7m.
- The essence feed (5) shall not be located higher than 4m above the essence pump.

Installation:

- Install essence reservoir (3) in the proper position.
- Install the peristaltic pump (2) above the essence reservoir (but no higher than 1.7m).
- Install suction pipe between peristaltic pump (2) and essence reservoir (3).
- Install essence return line between peristaltic pump (2) and essence reservoir (3) (only valid for peristaltic pump type HygroMatik DSP9911).
- Install line (4) between peristaltic pump (2) and essence feed (5).

6.3 Fan

In any steam bath, an exhaust fan (10) should be installed. The fan removes warm air from the steam bath in order to ensure continuous steam supply and stable temperature control.

Depending on the configuration of the steam bath, an air supply fan (8) can also be operated.

In the steam bath, the exhaust fan should be installed:

- high up and across from the air supply vent.

In the steam bath, the supply fan should be installed:

- down low and across from the exhaust vent.

6.4 Light

Cabin lighting may also be connected to the steam generator.

7. Parameters

Parameter	Designation	Possible Settings	Parameter description	Menu/Sub-menu
A4	Standby Blow-down	0 - 1440 Min.	If the controller demands no steam from the steam generator for a long period of time, it is advisable to flush out the cylinder water. At Parameter A4 Stand-By Blow-Down, the time period is set after which the complete blow-down is automatically performed. Water will not be fed into the cylinder until a new demand signal is received.	Operator-menu/ Blow-down
A 17	Stand-by heating	Yes (On) No (Off) Factory setting = Off	In the stand-by heating the actual steam operation (steam production) is interrupted. However, periodically for a <i>heating time</i> (parameter C17), the main contactor is activated and heats the water in the cylinder. After the <i>interval standby heating</i> (parameter C16) is the next heating period. Stand-by heating can only be active in ECO mode.	ECO/Settings
C17	Heating time Stand-by heating	0 - 255 Sec. (60 sec is Factory setting)	See declaration on parameter A17 (Stand-By heating).	ECO/Settings
C16	Interval Stand-by heating	0 - 255 Min. (60 min is Factory setting)	See declaration on parameter A17 (Stand-By heating).	ECO/Settings
D5	Limitation of operating time	0 - 1440 Min. (0 is Factory setting (=off))	With this parameter you determine if and when the steam generator should stop operation after the safety interlock has been closed. If the steam generator stops the operation modus LED lights pink . By opening and closing the safety interlock the steam generator restarts operation for the programmed hours.	Operator menu
D6	Limitation of operating time ECO Mode	0 - 1440 Min (0 is Factory setting (=off))	With this parameter you can set how long the steam generator works in ECO mode. Neither exhaust fan nor supply fan run within the ECO operating time.	Operator menu
G0	Calibration °C actual value	0,0 to 20,0 K (0 is Factory setting)	Using this Parameter, one can calibrate the temperature sensor connected to terminals 6 and 7. Note: The sensor is calibrated at the factory. Readjustment with a 2nd. temperature gauge is possible within a range of -5K to +5K.	Steambath/ Temperature

Parameter	Designation	Possible Settings	Parameter description	Menu/Sub-menu
G1	Hysteresis 1 controller	0,5 - 5,0 K 0,5 K = Factory Setting	Using this parameter, you can modify the differential between the activation and deactivation points of the temperature controller. The steam generator shuts off at a temperature of Steam Bath °C Set Value (G2) + Hysteresis Controller (G1) . Example: G2 is set to 45°C and G1 is set to 0.5 K. The steam generator shuts off at 45.5°C and switches on again at 45°C.	Steambath/ Temperature
G2	Steam Bath °C set Value	0 - 49 °C 45 °C = Factory Setting	Using this parameter, you can set the desired temperature in the steam bath. Changes to this setting in Operating Mode are saved when the steam generator is switched off.	Steambath/ Temperature
G3	Hysteresis exhaust fan	0,5 - 5,0 K 0,5 K = Factory Setting	This parameter sets the release point for the fan during steam bath operation. The fan shuts off when the steam bath temperature falls to the value "Steam Bath °C Set Value (G2) - Hysteresis Exhaust Fan (G3)". Example: G2 is set to 45 °C and G3 is set to 2 K. The fan switches off at 43 °C. The preset value is 0,5 K. Values between 0 and 10 K are possible.	Steambath/Fan
G13	Hysteresis supply fan	0,5 - 5,0 K 0,5 K = Factory Setting	The supply fan is activated until the programmed value Steam Bath °C Set Value (G2) + Hysteresis Supply Fan (G13) is reached. If the temperature rises above this value, the supply fan is switched off again.	Steambath/Fan
G32	Temperature preservation	Yes (On) No (Off)	This parameter sets, if the steam is to be kept at a lower temperature than the desired temperature (G2). Temperature preservation can only be active in ECO mode.	ECO/Settings

8. Electrical Connection

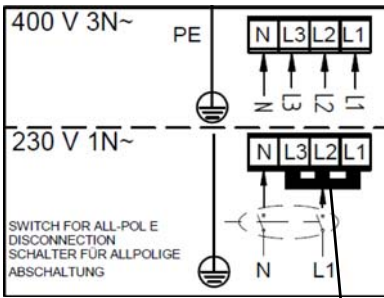

Jumper

8.1 Power Supply

The steam generator HeaterSlim is prepared for the connection to a power supply 400V 3 N ~.

With the enclosed jumper this connection can be adapted to a power supply 230 V 1 N~. Please gather the respectively valid electrical characteristics from the table „Technical Specifications“.

8.2 Remote Switch / Safety Interlock

The steam generator is only allowed to start operation if the contact between terminal 1 and 2 is closed (see chapter „Wiring Diagram“). If neither a Remote Switch nor any safety devices are wired to terminal 1 and 2 an electrical bridge has to be set.



Remote Switch

Note: Factory setting is that terminal 1 and 2 are not bridged.

Terminals 1 and 2 are available if an external on/off switch for the steam generator is desired. If terminals 1 and 2 are bridged, the steam generator can begin operation. If the contact between terminals 1 and 2 is open, the steam generator is idle.

Safety Interlock

Parallel with the function indicated above, the wire between terminals 1 and 2 is used as a safety interlock. Circuit protection devices, for example an emergency shut-off switch or max.-thermostat, can be wired in here.



Warning: Installation of a max.-thermostat in the safety interlock is advised to protect against temperature sensor failure or overheating. Alternatively, a second temperature sensor can be connected to the optional Relais-Box.

Circuit Protection Device

Humidifier Terminals



Safety Interlock and Remote Switch

If a circuit protection device and a remote switch are employed simultaneously, they are connected in series.

Remote Switch

Circuit Protection Device



Humidifier Terminals



Warning: Contacts connected to terminals 1 and 2 must be potential-free and rated for 24V switching.

Only safe low voltage (24V) may be used in the steam cabin.

8.3 Function Steam Boost

A push button can be attached to clamps 8 and 9 on the main board. If this is pushed, the steam generator produces steam for a certain time (factory setting: 15 seconds) and allows an excess temperature (factory setting: setpoint of temperature +2° K).

It is prerequisite that the safety chain is closed.

8.4 Switch Outputs for the Messages Collective Fault, Exhaust Fan, Essence (1) and Light

There are four switching relays on the mainboard:

Transmitting relay / contact	Contacts	Factory setting of switching message
1	29 (NC contact) 30 (NO switch)	Supply fan
2	31 (NC contact) 32 (NO switch)	Exhaust fan
3	33 (NC contact) 34 (NO switch)	Essence 1
4	35 (NC contact) 36 (NO switch)	Light

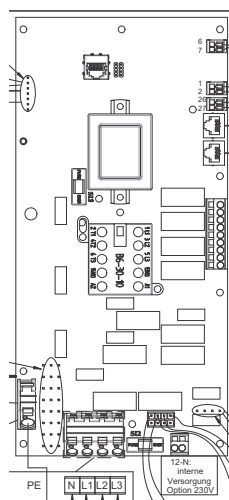

8.4.1 24V or 230V Connections

At the time of delivery of the steam generator, the relay exits for the messages supply fan, exhaust fan, essence (1) and light are still potential-free, i.e. they **do not switch any voltage**.

Switching voltage requires that contact 28 is supplied with the required voltage (choice of 24V or 230V). Mixing different voltages is not possible.

The total current on clamp 28 may not exceed 8A.

8.4.1.1 230V Connection, Relay Exits on the Mainboard

The 230V switching voltage for the relay exits must either be led to contact 28 of the 1st relay (by the customer) or can be picked off internally from clamp KL1 (contact 12) on the mainboard and be connected. In the last case, the relay exits are secured automatically with 1.6A.

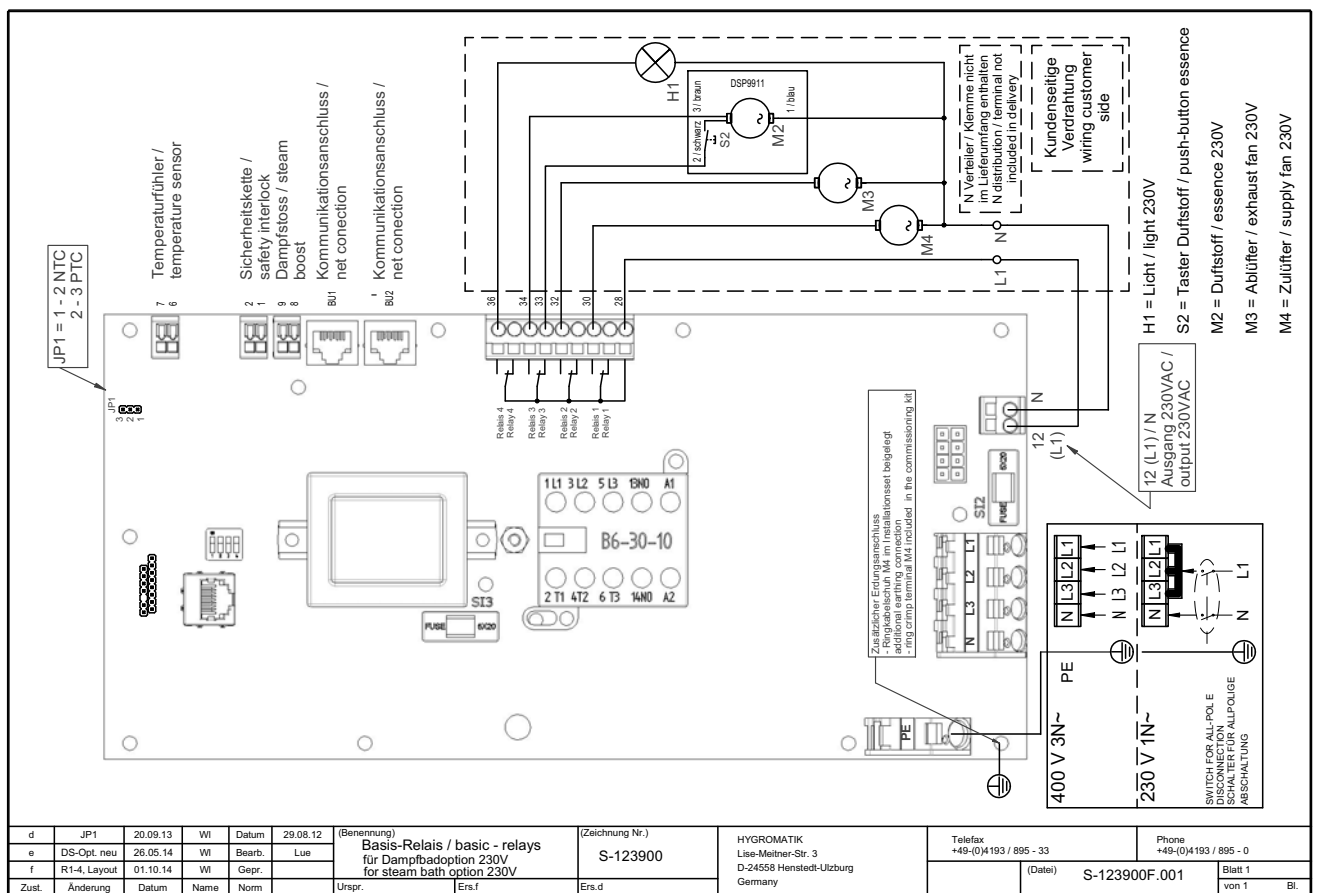

8.4.1.2 24-V Connection, Relay Exits on the Mainboard

The 24V switching voltage for the relay exits must be led (by the customer) to contact 28 of the 1st relay.

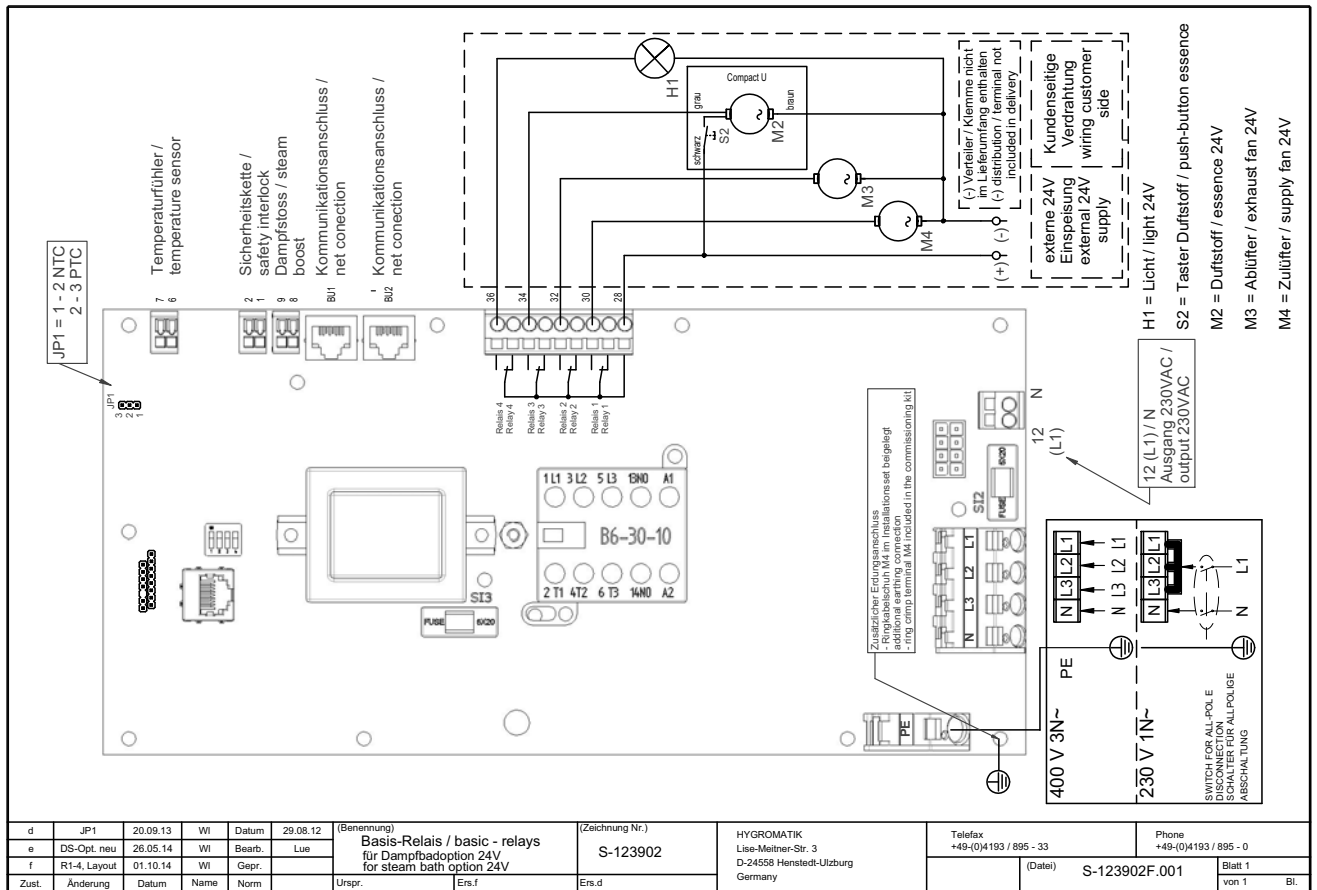

Note: If the optional 24V relay box is used, you will find 4 additional switching relays there which are prepared for connection to 24V devices.

8.5 Relay Box Option

The optional relay box provides 4 additional switching relays and is available with 24V or 230V.

The switching relay exits are ready to be connected and secured. The delivery condition configuration of the relays is as follows.

Transmitting relay / contact	Contacts	Factory setting of switching message
1	40 41 (NC contact) 42 (NO switch)	Essence 2
2	43 44 (NC contact) 45 (NO switch)	Essence 3
3	46 47 (NC contact) 48 (NO switch)	Supply fan
4	49 50 (NC contact) 51 (NO switch)	Exhaust fan

The relay box also provides the optional connection of a 2nd temperature sensor.

The 2nd temperature sensor serves for safety control of the main temperature sensor and can be identical in structure. It is offered as an option by HygroMatik and should be installed in close vicinity of the main sensor.

Additional programming for the 2nd temperature sensor is not required. However, the safety chain of the mainboard (terminal 1, 2) must be connected with terminals 1Out and 2Out of the relay box for the full range of functions. If the terminals 1 and 2 (of the mainboard) are already in use with a safety device (or bridge), please remove it and connect it to terminals 1In and 2In of the relay board.

If there is no safety device that has to be connected to terminal 1In and 2In these contacts have to be bridged.

8.5.1 230V Relay Box

8.5.1.1 230V Relay Box Connection



Note: Connection of the communication line only when the steam generator is turned off.

The relay box is equipped with cable screw connections.

This guides the electrical cables for the following connections:

- 230V power supply
- External 230V consumers like essence pumps, fan, light
- Communication line (cable with RJ45 plugs, available from HygroMatik with the lengths 3, 5, 10m) from relay box (socket BU1) for electronics (socket BU2) of the steam generator



Note: If an option 230V is used the jumper JP2 on the circuit board stands on position "Bus".

OPTION 230V

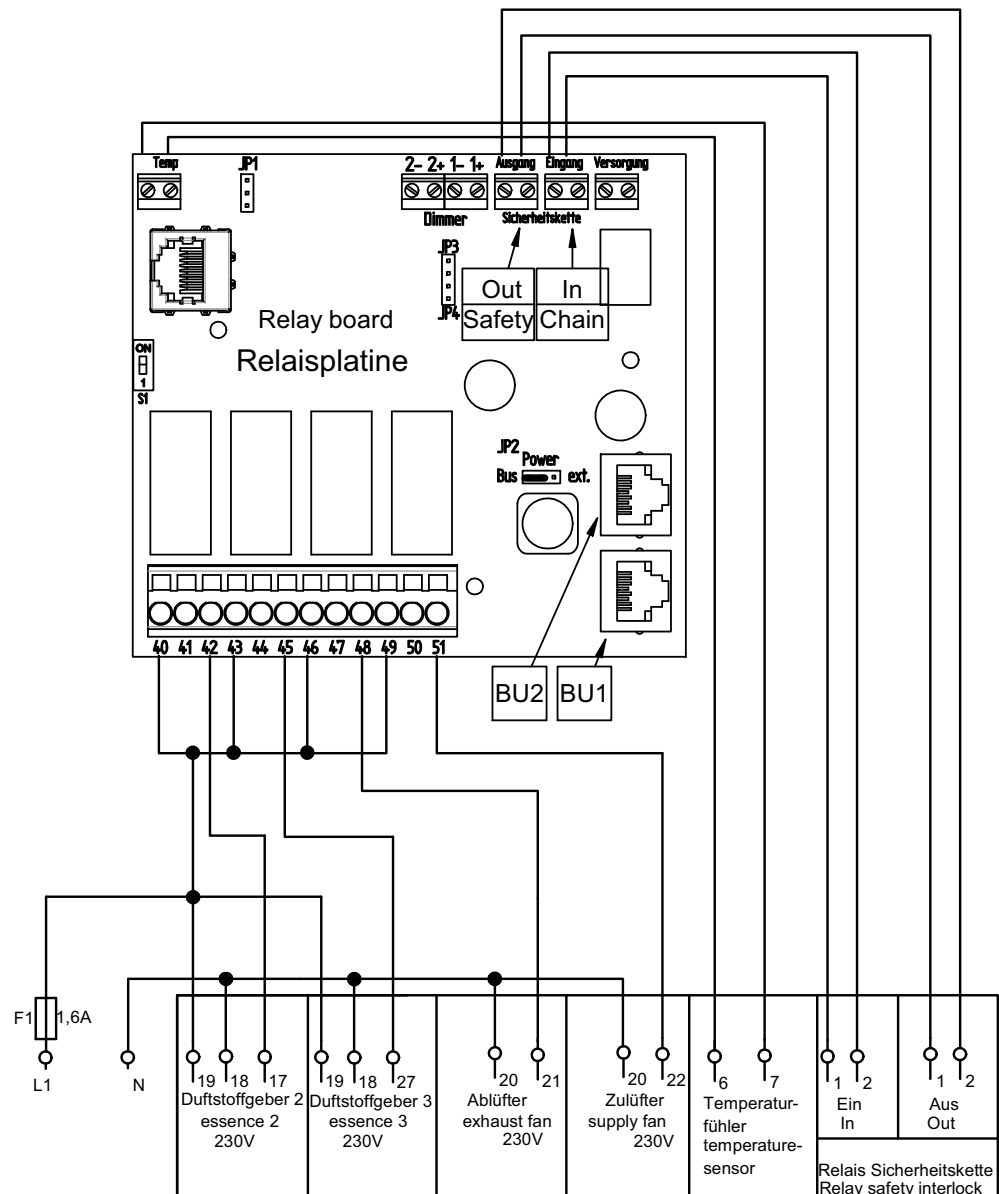

8.5.2 24V Relay Box

8.5.3.1 24V Relay Box Connection

The relay box is equipped with cable screw connections.

This guides the electrical cables for the following connections:

- 230V power supply (switched to low voltage of 24V with integrated transformer)
- External 24V consumers like essence pumps, fan, light
- Communication line (cable with RJ45 plugs, available from HygroMatik with the lengths 3, 5, 10m) from relay box (socket BU1) for electronics (socket BU2) of the steam generator



Note: If an option 24V is used the jumper JP2 on the circuit board stands on position "extn.".

OPTION 24V

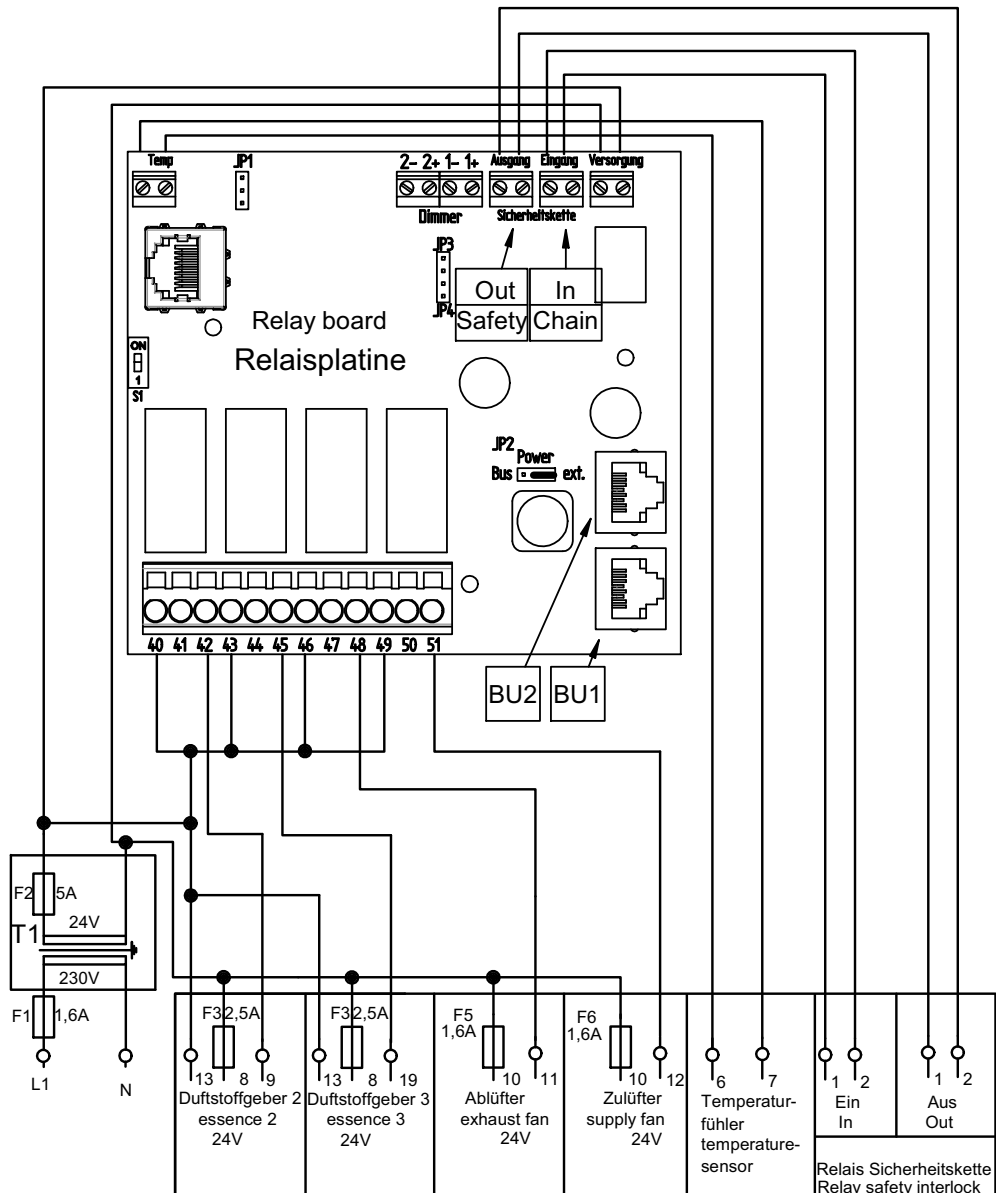

9. Initial Operation



Warning: The unit may only be started up by qualified personnel.



Switch off steam generator:

Warning: Before starting up the unit for the first time, you must know how to switch it off.

- » Switch off the unit by means of the control switch.
- » Close the water supply shut-off valve.

Switch on steam generator:

- » Open fresh water shut-off valve.
- » Switch on unit by means of the control switch.

The following functions are executed during the start-up routine:

- The unit performs self-tests.

If the cabin temperature is a) below setpoint of **temperature** and b) if the **safety interlock** is closed (please see also chapter „Remote Switch / Safety Interlock)

the humidifier starts to produce steam.

Additional Checks:

- All electrically-driven operations must be allowed to run to completion.

As soon as the solenoid valve periodically feeds water, operation with nominal output has been achieved and the cold start-up procedure is completed.

- » Monitor the unit and allow to run for 15-30 minutes. If leakage occurs, switch off the unit.
- » Repair leaks.



Danger, Hazardous Voltage: Follow safety instructions for work on live components.



Danger, Hazardous Voltage: The humidifier cover must be closed and secured.



Note: The Armaflex insulation on the cylinder may smell in the beginning.

10. Wiring Diagram

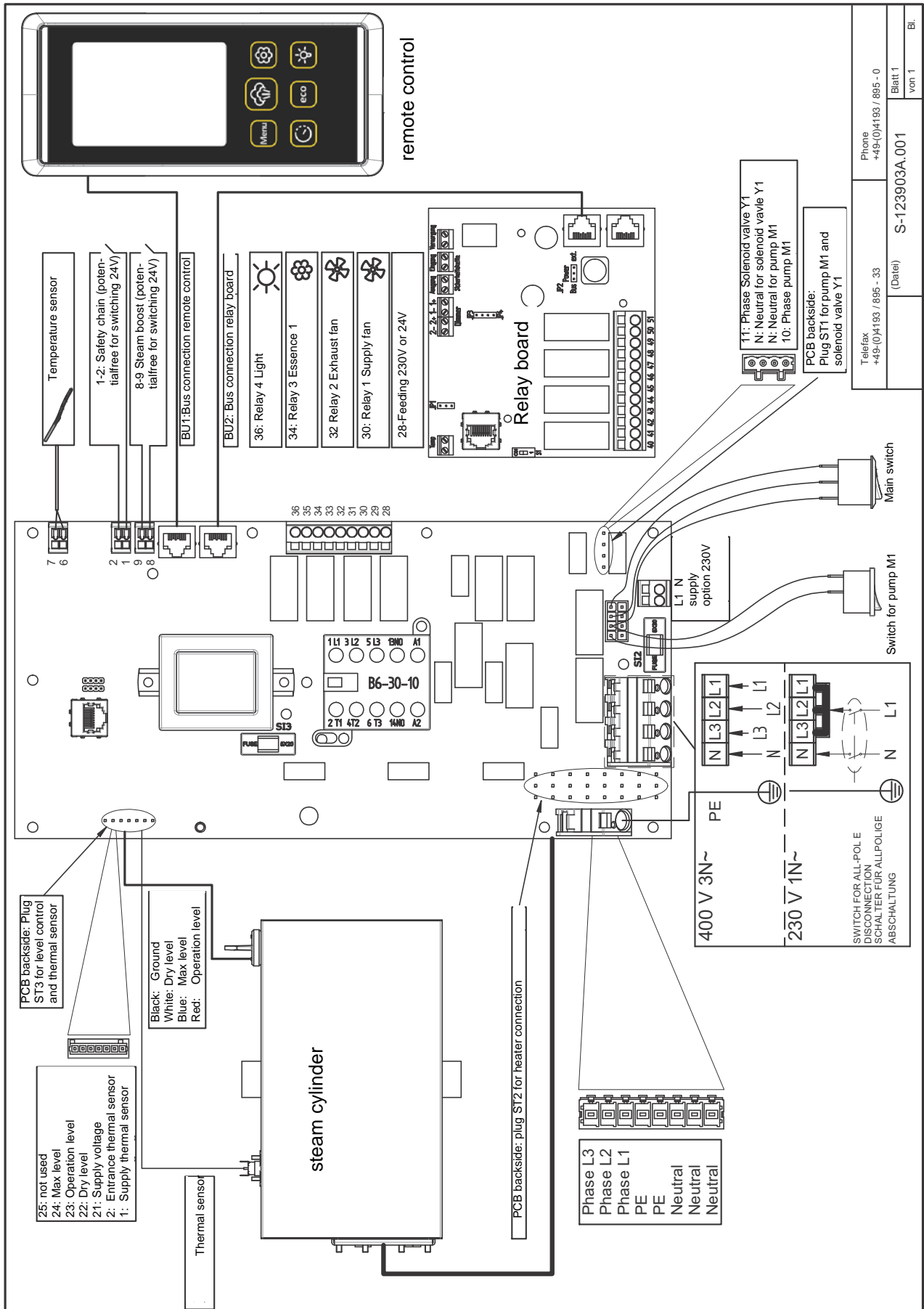

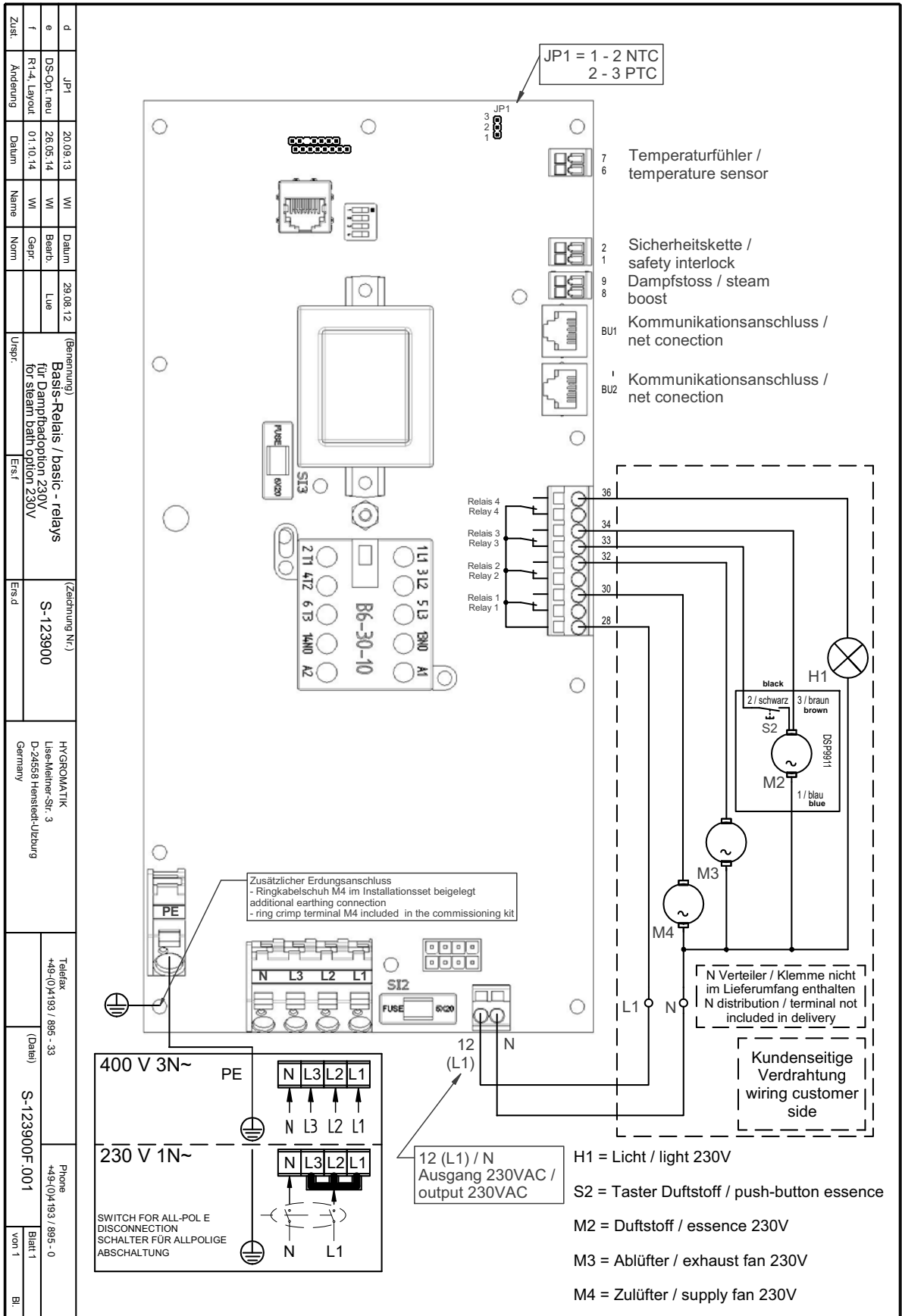

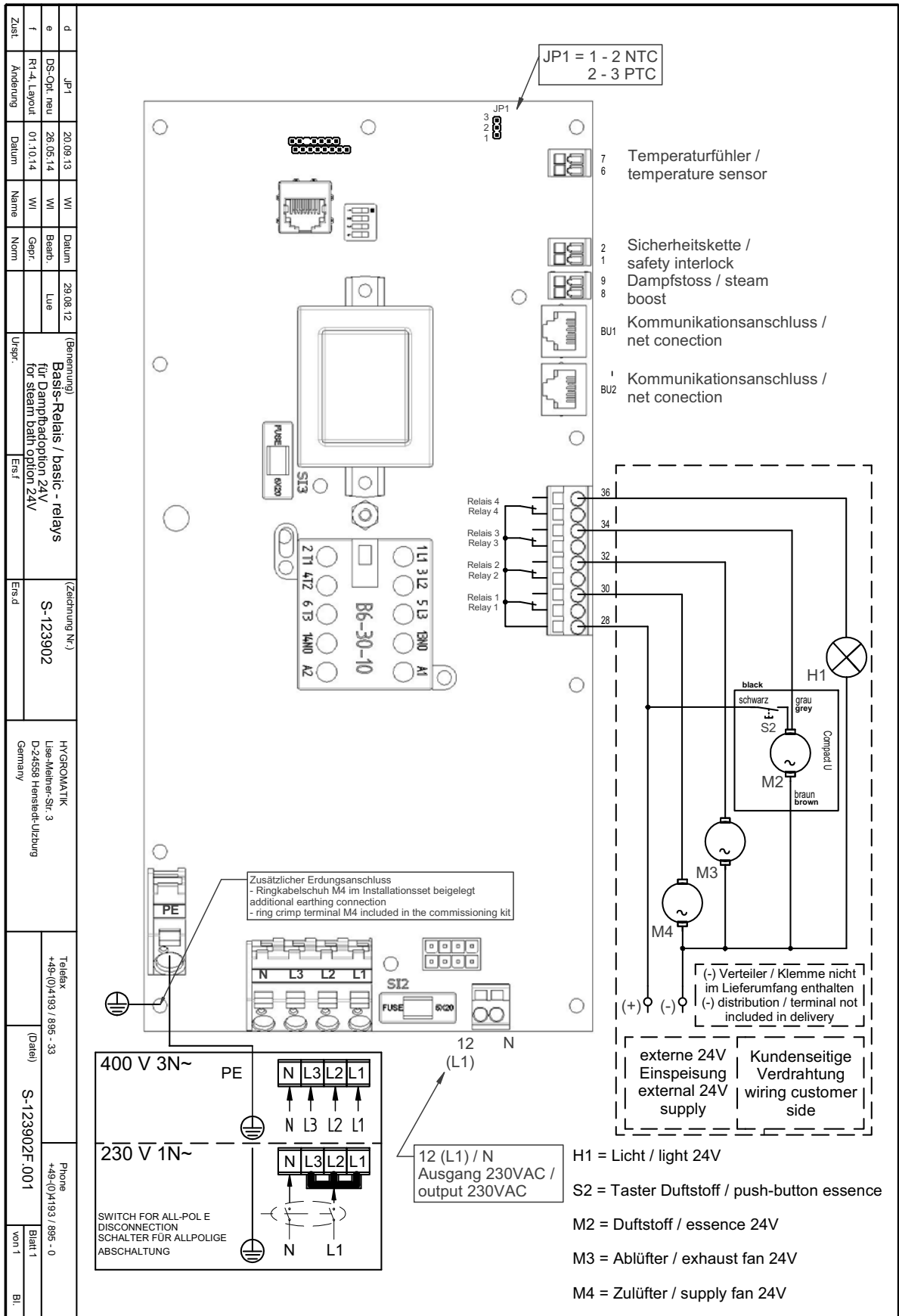

OPTION 230V

OPTION 24V

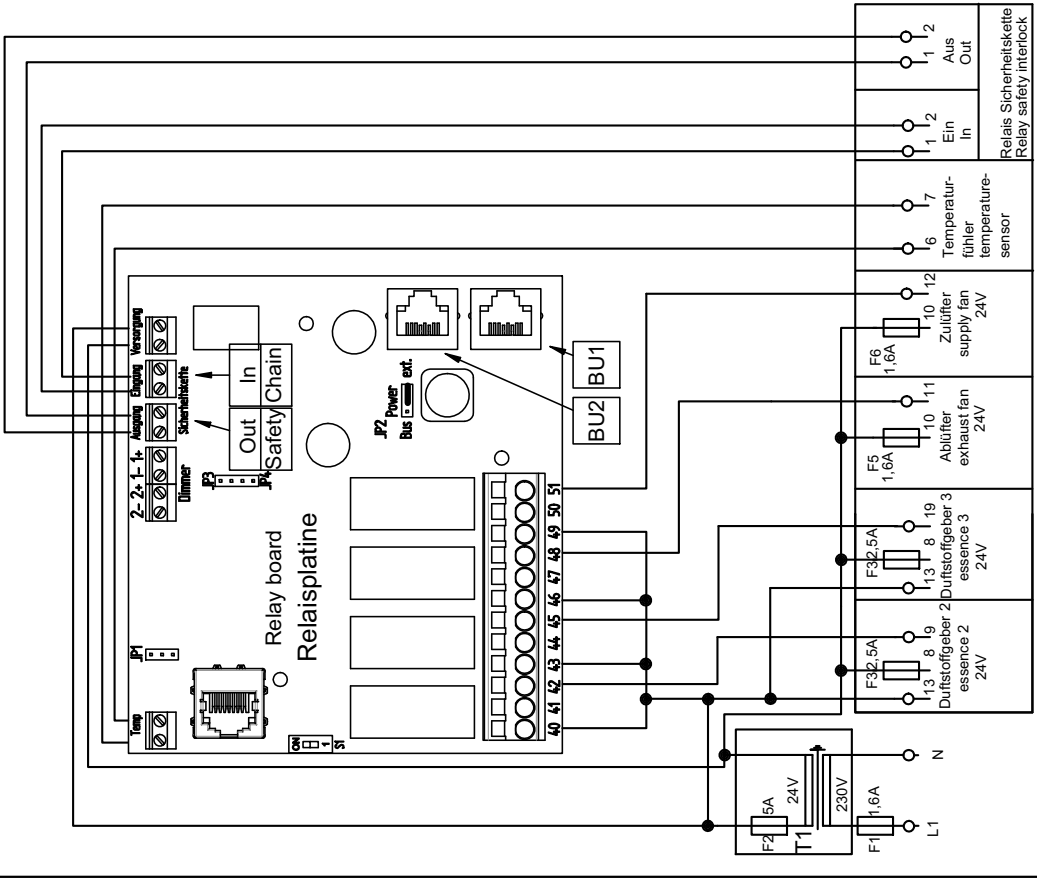
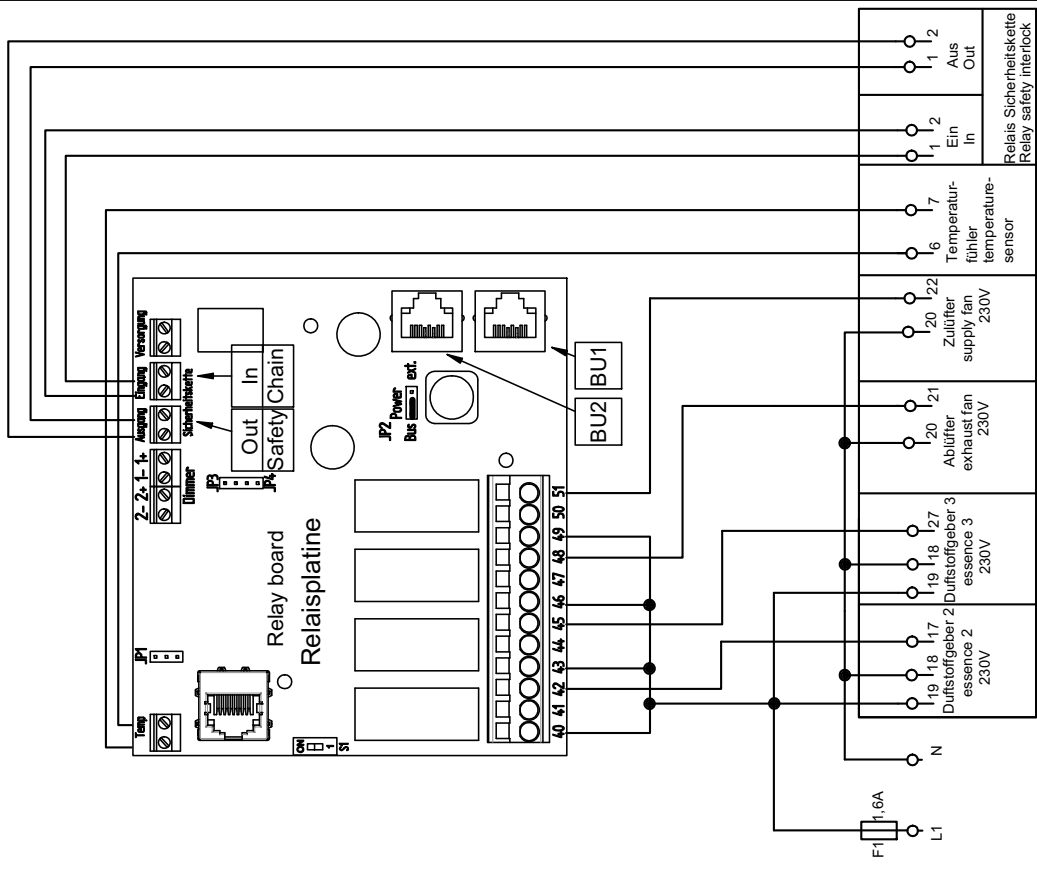

a	Freigabe	29.08.12	Lue	Datum	29.08.12	(Benennung)	Relaisbox / relay box für Dampfbadoption 24V + 230V for steam bath option 24V + 230V	S-123901	HYGROMATIK Lise-Meiner-Str. 3 D-24658 Henstedt-Ulzburg Germany	Telefax +49-(0)4193 / 995 - 33	Phone +49-(0)4193 / 995 - 0
	Zust.	Änderung	Datum	Name	Norm	Gepr.	Bearb.	Lue	(Date)	S-123901A.001	Blatt 1 von 1
											Bl. von 1

11. Faults and Messages / Conditions



Switch off the steam humidifier immediately if a fault occurs. Faults are only to be remedied by qualified personnel following the proper safety instructions.

If an error occurs, the main switch flashes. Different flashing codes describe different error messages. A blink code sequence consists of 7 LED states. The following table shows the assignment of Flash code to an error message.

Fault	Flash code
Fault blow-down	S,O,S,O,S,O;S
Fault full blow-down	L,O,S,O,S,O,S
Fault filling	S,O,L,O,S,O,S
Fault thermo sensor	L,O,L,O,S,O,S
Fault max.-level	S,O,S,O,L,O,S
Fault level sensor	S,O,L,O,L,O,S
Fault steam down time	L,O,L,O,L,O,S
Fault °C sensor	S,O,S,O,S,O,L
Fault °C max	L,O,S,O,S,O,L
Fault °C sensor 2	S,O,L,O,S,O,L
Fault °C max 2	L,O,L,O,S,O,L
Fault temperature deviation	S,O,S,O,L,O,L
System Failure	L,O,S,O,L,O,L

S: Short = 0,5 sec flashing time

L: Long = 3 sec flashing time

O: Off = 0,5 sec timeout

After every complete flash code the LED is off for 5 seconds.

The steam generators and HeaterSlim-TRS and HeaterLSlim-TS are equipped with a display that gives an additional and detailed error description in the event of a fault.

Message / Malfunction Displayed*	Probable Cause	Resolution
Fault blow-down / Fault full blow-down Unit shuts off automatically	<ul style="list-style-type: none"> • Blow-down pump has not been electrically activated <ul style="list-style-type: none"> - Cable connections are faulty. - The relay on the main PCB is not operating. • Defective blow-down pump • Solenoid valve does not close properly. Water level in the cylinder sinks very slowly even though blow-down pump flushes out water. • Blow-down pump operates, but no water is pumped out, i.e. the cylinder drain is blocked. • Blow-down pump is blocked up with mineral deposits. 	<ul style="list-style-type: none"> • Check or replace cable connections. • Measure voltage at PCB. Terminals against N or replace PCB. • Replace blow-down pump. • Check solenoid valve. • Thoroughly clean steam cylinder and base to prevent short-term blockage from reoccurring. • Check blow-down pump, drain assembly and cylinder for mineral deposits and clean.
System failure Unit shuts off automatically	<ul style="list-style-type: none"> • Mainboard is defective.. 	<ul style="list-style-type: none"> • Check mainboard. If necessary - change mainboard.
Fault Max.-Level Unit shuts off automatically.	<ul style="list-style-type: none"> • If the water level "max. level" is reached, the pump switches on and drains the cylinder until the water level lowers to "operation." If the "max.-level" is reached five times, "max.-level" is displayed. • Solenoid valve does not close properly. Water level in the cylinder rises slowly even though the solenoid valve has not been activated. • Water is supplied even though the steam humidifier is switched off. Solenoid valve remains open. 	<ul style="list-style-type: none"> • Check solenoid valve. • Clean solenoid valve.
Fault filling Unit shuts off automatically.	<ul style="list-style-type: none"> • Solenoid valve is fouled or defective. • Strainer in steam cylinder is dirty. • Defective coil. • Water supply is not open. • Solenoid valve has not been electrically activated. <ul style="list-style-type: none"> - The cable connections are faulty. - The relay on the main PCB is not operating. • The steam hose has not been laid at enough of an incline, causing a water pocket to form. The steam flow is obstructed. 	<ul style="list-style-type: none"> • Clean or replace solenoid valve. • Clean strainer. • Measure coil and replace. • Open water supply. • Check or replace cable connections. • Measure voltage at PCB terminal against Nor replace PCB. • Check placement of steam hose. Remove water pocket.

Message / Malfunction Displayed*	Probable Cause	Resolution
Fault °C sensor Unit shuts off automatically.	<ul style="list-style-type: none"> • Temperature sensor or line defective. • Short circuit in sensor wire (no resistance). 	<ul style="list-style-type: none"> • Check temperature sensor and sensor line, replace if needed. • Replace temperature sensor.
Fault level sensor Unit shuts off automatically.	<ul style="list-style-type: none"> • Water level sensor is defective. • Cable connections for the water level sensor are faulty. 	<ul style="list-style-type: none"> • Dismantle and check water level sensor. Clean sensor if necessary • Check cable connections, replace if needed.
Fault °C Max Unit shuts off automatically.	<ul style="list-style-type: none"> • Heat buildup in the cabin. • Additional heat source in the steam cabin. 	<ul style="list-style-type: none"> • Ensure continuous heat removal.
Fault thermo sensor Unit shuts off automatically.	<ul style="list-style-type: none"> • Thermo sensor has been activated. • Plug for the water level sensor is not connected to the control. 	<ul style="list-style-type: none"> • Disconnect power supply. Press the release pin back down with bent needle-nose pliers or a screwdriver. • Connect plug to the control.
Fault steam-down time exceeded Unit shuts off automatically.	<ul style="list-style-type: none"> • Heater element is defective. • Phase failure. (External breaker has been tripped or is defective.) • Heater element is not being supplied with current. • Main contactor is not switching correctly. • PCB does not activate main contactor. 	<ul style="list-style-type: none"> • Replace heater element and identify cause. • Replace circuit breaker and identify cause. • Check cable connections. Measure voltage. • Check main contactor, replace if needed.. • Measure voltage at PCB against N. Replace PCB if necessary.
Fault °C sensor 2 Unit shuts off automatically.	<ul style="list-style-type: none"> • Temperature sensor 2 or line defective. • Short circuit in sensor wire (no resistance). 	<ul style="list-style-type: none"> • Check temperature sensor 2 and sensor line, replace if needed. • Replace temperature sensor 2.
Fault °C Max 2 Unit shuts off automatically.	<ul style="list-style-type: none"> • Heat buildup in the cabin. • Additional heat source in the steam cabin. 	<ul style="list-style-type: none"> • Ensure continuous heat removal.

Message / Malfunction Displayed*	Probable Cause	Resolution
Fault temperature deviation	<ul style="list-style-type: none"> • There is a deviation of more than 3° C between the reported values from the 1st and 2nd (optional) temperature sensor due to a positioning being apart in the cabin or due to a defective temperature sensor. 	<ul style="list-style-type: none"> • Check positioning of temperature sensors and operability; replace if needed.
Safety stop	<ul style="list-style-type: none"> • Parameter for limitation of operating time is activated. The steam generator stopped operation after the safety interlock has been closed for the programmed time. 	<ul style="list-style-type: none"> • By opening and closing the safety interlock the steam generator restarts operation for the programmed hours. <p>Alternatively set parameter for „limitation of operation time“ to 0 and restart system. The function „limitation of operating time“ is deactivated.</p>
Service	<ul style="list-style-type: none"> • The service interval is displayed when the preset amount of steam was produced or the preset number of switching cycles of the main contactor has been reached. 	<p>The service message can be reset in the menu Service or via the DIP switches on the main PCB.</p>

Possible Conditions	Probable Cause	Resolution
Water is collecting on the base plate	<ul style="list-style-type: none"> • Cylinder improperly assembled after maintenance: O- Ring has been damaged, has not been replaced, or has not been inserted <ul style="list-style-type: none"> - Flange has not been sealed properly - Mineral deposits in the flange. • The water cannot drain away during flushing. 	<ul style="list-style-type: none"> • Clean cylinder and install properly. • Make sure drain is unobstructed.
No steam production, even though the steam generator has been activated. The display is active.	<ul style="list-style-type: none"> • The heater element or thermo sensor has not been properly installed. • Steam hose adapter has not been correctly installed or o-ring has not been changed. • If the temperature exceeds the set desired value, no steam demand is present. • The unit has been switched off remotely. (Terminals 1 and 2 in the steam generator are not bridged.) • Poor air circulation, steam bath temperature has remained above the programmed set value for a long period of time. 	<ul style="list-style-type: none"> • Install heater element and thermo sensor as specified in the unit manual. • Replace o-ring and correctly install steam hose adapter. • Check desired and actual temperature values. • Switch on the unit using the remote switch, or install a jumper between terminals 1 and 2. • Install a fan.
	<ul style="list-style-type: none"> • Water supply is not open or solenoid valve has not been electrically triggered. 	<ul style="list-style-type: none"> • Open water supply. • Also see Fault Filling.
The set temperature has not been reached.	<ul style="list-style-type: none"> • Incorrect output estimate. • Phase failure. (external fuse) 	<ul style="list-style-type: none"> • Check output data, steam bath insulation and dimensions. • Install fuse.

Possible Conditions	Probable Cause	Resolution
No visible steam in the cabin.	<ul style="list-style-type: none"> • Steam bath is too well insulated. • Insufficient air circulation in the steam bath. • Excessive heat supply (i.e. from heated benches). 	<ul style="list-style-type: none"> • Provide for removal of heat. • Install exhaust fan or check exhaust fan performance. • Reduce ancillary heat supply.
Temperature is too high	<ul style="list-style-type: none"> • Temperature sensor has not been correctly calibrated. 	<ul style="list-style-type: none"> • Check Parameter "Adjustment Actual Temperature Value" (G0).
Essence delivery into the steam bath is absent or insufficient	<ul style="list-style-type: none"> • No essence in reservoir. • Essence injector has not been activated. • Fuse or relay in the control for essence delivery is faulty (when employing 24 V). • Tube in peristaltic pump is defective (essence flows back into the essence reservoir through the return line). 	<ul style="list-style-type: none"> • Replenish essence. • Activate essence injector. (Check power supply to the essence solenoid valve and peristaltic pump). • Replace fuse. (Check power supply to the essence solenoid valve.) • Replace tube into peristaltic pump.
Excessive essence delivery into the steam bath Blow-down pump is working, but no water is being flushed	<ul style="list-style-type: none"> • Essence intensity is too high. • Cylinder base or blow-down system is blocked. 	<ul style="list-style-type: none"> • Reduce essence intensity. • Clean cylinder base or blow-down system.
Cylinder has completely drained after a blow-down, even though pump is switched off.	<ul style="list-style-type: none"> • Vent pipe is blocked. 	<ul style="list-style-type: none"> • Clean or replace vent tube. Replace vent pipe adapter. Also see unit manual.
No steam is exiting the steam nozzle. Water leaks periodically from the drain hose while the pump is not running.	<ul style="list-style-type: none"> • false steam direction installation (waterbag). • Blockage in steam pipe work. 	<ul style="list-style-type: none"> • Lay steam hose as specified in Section "types of installation" in the unit manual. • Remove blockage.

12. Technical Specifications

Heater Element Steam Generator						
Type HeaterSlim	HS03	HS06	HS10	HS03	HS06	HS10
Steam Output [kg/h]	3,3	6,6	10,0	3,3	6,6	10,0
Electrical Supply*	230V/1/N			400V/3/N 50-60Hz		
Power Rating [kW]	2,5	5,0	7,5	2,5	5,0	7,5
Power Consumption [A]	10,9	21,7	32,6	10,9	10,9	10,9
Circuit Protection [A]	1x16	1x25	1x35	1x16	2x16	3x16
Control Type	Basic, Touch, Touch Remote					
Control Voltage	230V/50-60Hz					
Number of Heater Elements	1	2	3	1	2	3
* Other voltages upon request.						

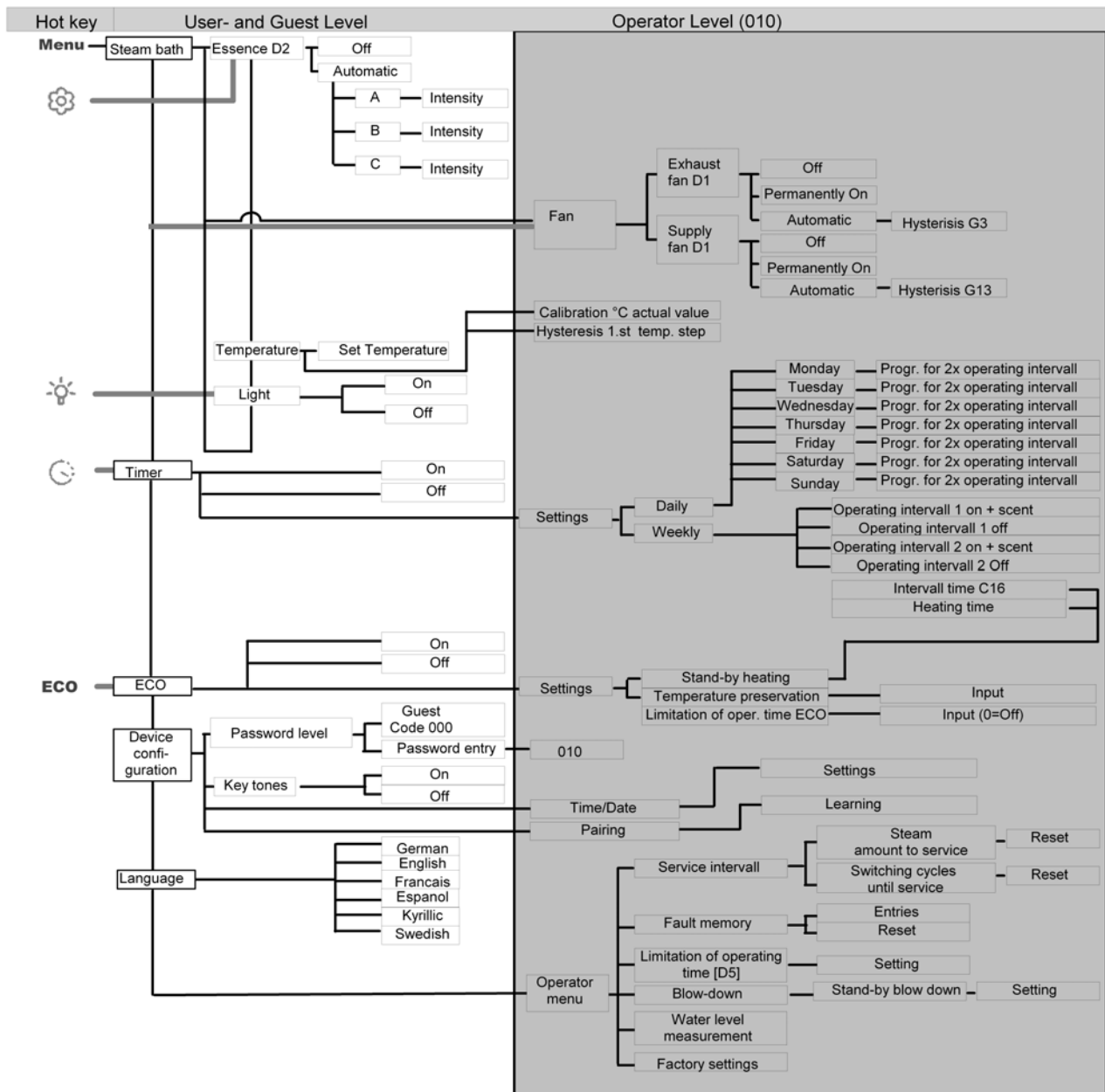



HyGROMATIK®

Lise-Meitner-Str.3 • D-24558 Henstedt-Ulzburg
Phone +49(0)4193/ 895-0 • Fax -33
eMail hy@hygromatik.de • www.hygromatik.com
A member of the **spirax**/**sarco** Group